

PUMP MODELS

▶ Agilent VHS-10

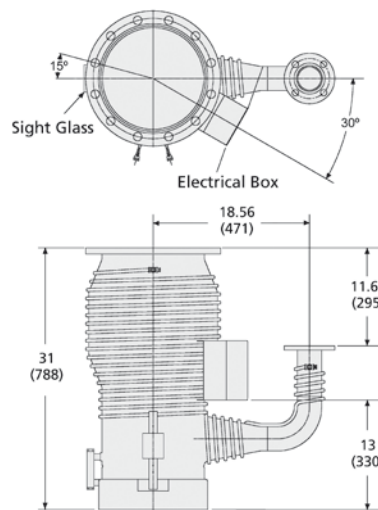

Dimensions: inches (millimeters)

Technical Specifications

Pumping speed, operating range	3,650 l/s air, 4,560 l/s He/H ₂
Pumping speed*, AVS 4.1 (1963)	5,300 l/s air
Maximum throughput	6.3 T-l/s (8.4 mbar l/s) in operating range, 7.5 T-l/s (10.0 mbar l/s) @ 0.01 Torr
Operating range	1.7 x 10 ⁻³ to <5 x 10 ⁻⁹ Torr at 4400 W (2.3 x 10 ⁻³ to <6.5 x 10 ⁻⁹ mbar)
Maximum forepressure	No load: 0.65 Torr (0.85 mbar) Full load: 0.55 Torr (0.72 mbar)
Recommended backing pump	≥ 30 cfm (51 m ³ /hr)
Backstreaming rate**, standard cold cap	<5.0 x 10 ⁻⁴ mg/cm ² /min
Warmup time	15 minutes
Cooldown time	25 minutes
Fluid charge	1,000 cc
Electrical requirements	3 ph, 50/60 Hz, 208/240/380/480 VAC
Pump power	4400 watts
Cooling water requirements	0.40 gpm (80 l/hr)
Water connections	½ in. FPT Tee

* For an explanation of pumping speed measurements, please see page 34.

** Refer to page 32 for a description of test methods.

DIFFUSION PUMPS

VHS-10 Pumping Speed - Air/N₂

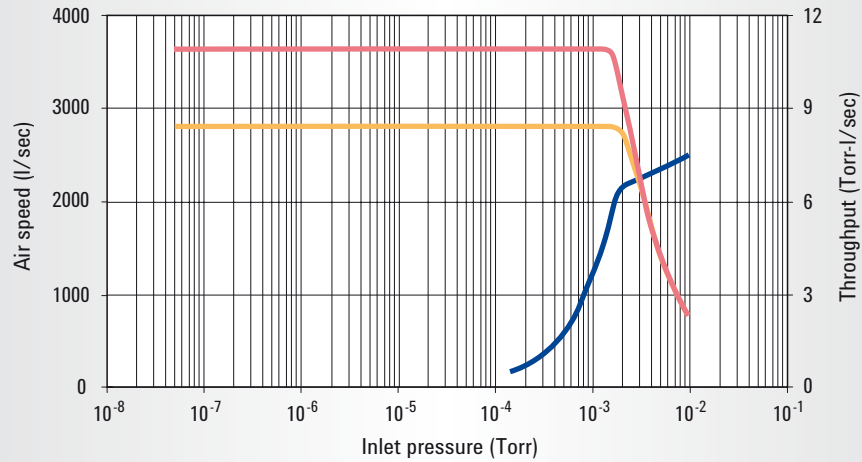

— Pumping speed/Standard cold cap — Pumping speed/Extended cold cap — Throughput

Ordering Information

Description	Wt. kg (lbs)	Part Number	
		ASA	ISO
VHS-10 with standard cold cap, 208 V	68 (150)	F0426307	L5920307
VHS-10 with extended cold cap, 208 V	68 (150)	F0426317	L5920317
VHS-10 with standard cold cap, 240 V	68 (150)	F0426308	L5920308
VHS-10 with extended cold cap, 240 V	68 (150)	F0426318	L5920318
VHS-10 with standard cold cap, 380 V	68 (150)	F0426326	L5920326
VHS-10 with extended cold cap, 380 V	68 (150)	F0426336	L5920336
VHS-10 with standard cold cap, 480 V	68 (150)	F0426309	L5920309
VHS-10 with extended cold cap, 480 V	68 (150)	F0426319	L5920319

Accessories	Wt. kg (lbs)	Part Number
Water-cooled baffle with ASA flanges	9.0 (20.0)	F8600310
Water-cooled baffle with ISO flanges	9.0 (20.0)	F8600311

NOTE

- Inlet flange 10 in. ASA, foreline flange 2 in. ASA
- Inlet flange ISO 320K, foreline ISO 63K
- See page 30 Santovac 5 diffusion pump fluid
- Baffles and extended cold caps can be found on page 31

Description	Wt. kg (lbs)	Part Number
Accessories (Cont'd)		
Centering ring for ISO foreline flange, 63K	0.5 (1.0)	IC063SV
Installation and Operation Manual (download from www.agilent.com/chem/vacuum)		699901023
Replacement Parts (two heaters required per pump)		
2200 W, 208 V heater	0.5 (1.0)	647310140
2200 W, 240 V heater	0.5 (1.0)	647310150
2200 W, 380 V heater	0.5 (1.0)	647310160
2200 W, 480 V heater	0.5 (1.0)	647310170
2550 W, 208 V heater	0.5 (1.0)	647310145
2550 W, 240 V heater	0.5 (1.0)	647310155
2550 W, 380 V heater	0.5 (1.0)	647310165
2550 W, 480 V heater	0.5 (1.0)	647310175
Heater crush plate (covers both heaters; one required for pump; replace when either heater is replaced)	1.0 (2.0)	K7667001
Heater clamping plate (one required per pump)	0.5 (1.0)	R2667301
VHS-10/400 heater wire, 10 AWG, 42 inches (3 per pump required)	1.0 (0.4)	X3901-68003
Replacement o-ring kit (kit contains: 1 inlet flange o-ring (butyl F0430001), 1 foreline flange o-ring (butyl 2-338), sight glass o-ring and gasket, 10 fill and drain o-rings (Viton 2-113))	1.0 (0.5)	K0377185
Thermal switch (set at 300 °F – 147 °C)	0.5 (1.0)	642906025
Extended cold cap	2.0 (0.9)	L8917301