

AGILENT TURBO PUMP MODELS

▶ Agilent Turbo-V 3K-G System

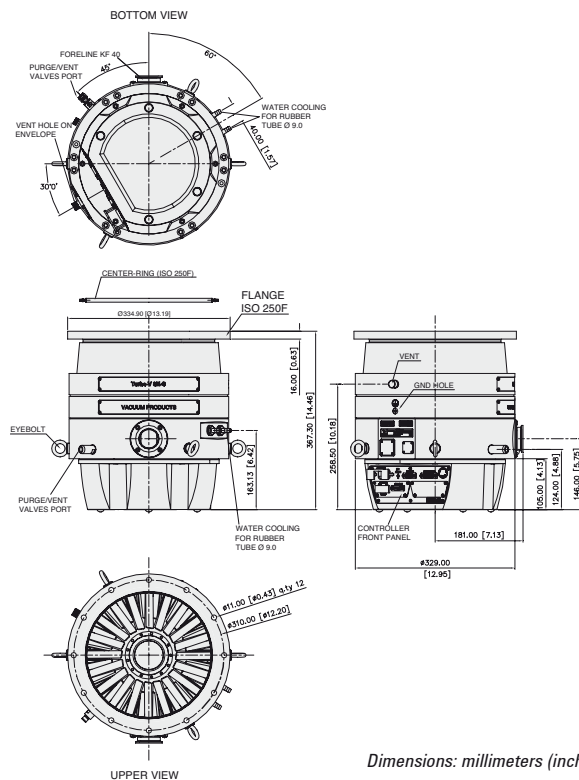

Dimensions: millimeters (inches)

The Only Truly “Integrated” System in the Market

The Turbo-V 3K-G: an advanced solution for Thin Film applications

- Fully integrated system with on board waterproof power supply
- Vent/purge valves control capability
- Integrated diagnostics
- Multiple interfaced capability
- Lowest power absorption

Best Footprint to Performance Ratio

- The highest Argon pumping speed (2050 l/s) for its size allows uniform deposition rates at high substrate throughput
- Highest pumping speed in its class: 2200 l/s for Nitrogen
- Throughput: over 1400 sccm for Nitrogen
- The all-turbo, more compact rotor design delivers highest performance with the smallest footprint

Technical Specifications

Pumping speed	N ₂ : 2200 l/s	He: 1900 l/s	Ar: 2050 l/s
Compression ratio	N ₂ : > 1 x 10 ⁷	He: 6 x 10 ³	Ar: > 1 x 10 ⁸
Base pressure* (with recommended forepump)	<1 x 10 ⁻⁸ mbar		
Inlet flange	ISO 250 F		
Foreline flange	KF 40 NW		
Nominal rotational speed	31,800 rpm		
Start-up time without gas load and with the recommended forepump	< 6 minutes		
Foreline pressure	< 0.5 mbar		
Minimum recommended forepump	> 60 m ³ /h (depending on gasflow requirements)		
Operating position	Any		
Cooling requirements	Water		
Weight (ISO 250)	52 kg (114.63 lbs)		

* According to standard DIN 28 428.

TURBO PUMPS

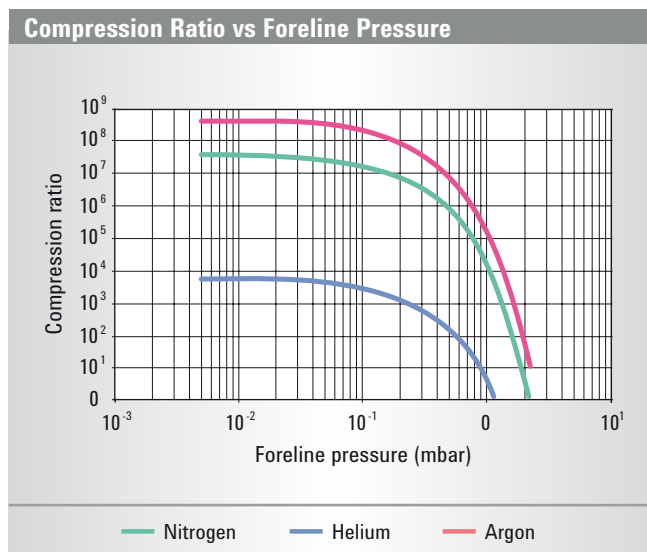
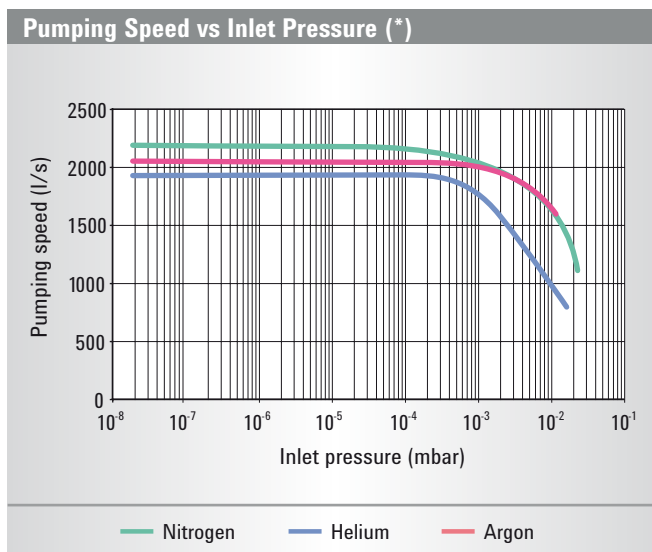

(*) Measured with a 60 m³/h forepump.

Ordering Information

Description	Part Number
Pumping Systems (*)	
Turbo-V 3K-G ISO 250 F System with integrated purge/vent device	9698888
Turbo-V 3K-G ISO 250 F System with Profibus and integrated purge/vent device	9698889
(*) Pumping Systems include Pump with 230 V Integrated Electronics, Inlet Screen installed on the pump, separate center-ring and pre-installed IP54 Mating Connectors. Both standard models can be equipped with Agilent's MoniTorr device on request. Also 120 Vac units available on request.	
Accessories	
Mains cable NEMA Plug, 3 m long	9699958
Mains cable European Plug, 3 m long	9699957
T-Plus Software and serial cable	9699883
Water cooling kit for 6x8 (IDxOD) flexible tube	9699348
Water cooling kit for 3/8 in.ID flexible tube	9699338
Spare Parts	
IP54 proof mating connectors	9699960
Inlet screen ISO 250	9699350
O-ring and center ring ISO250	9699144