

PUMP MODELS

▶ Agilent TriScroll 300

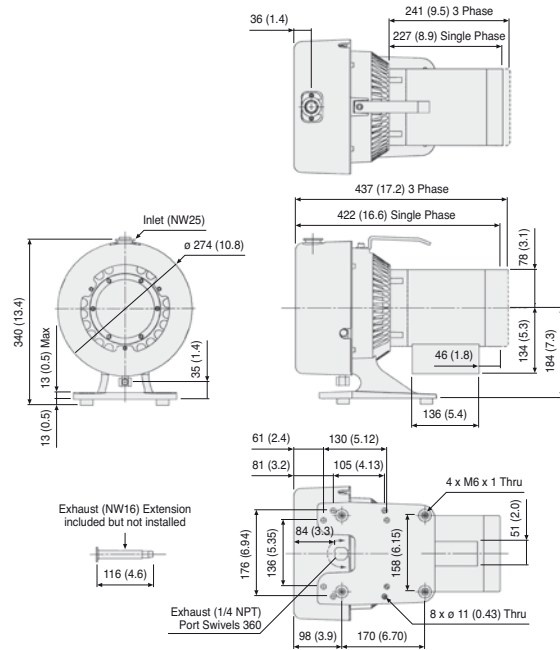

Dimensions: millimeters (inches)

The TriScroll series are two-stage dry scroll pumps that have high pumping speeds and low base pressure. TriScroll pumps eliminate the frequent maintenance requirements of oil-sealed rotary vane pumps, simplifying regulatory and environmental compliance, and eliminating oil disposal costs. The unique, patented TriScroll features proven reliability and durability, delivering consistent performance and superior cost of ownership.

- High pumping speed and low ultimate pressure provide clean, dry vacuum
- Long-life tip seals routinely last more than a year before replacement
- Bearing purge port permits simple maintenance and delivers long bearing life
- Automatic air ballast manages water vapor without reducing pumping speed

Technical Specifications

Pumping speed	60 Hz: 250 l/m, 15 m ³ /hr, 8.8 cfm 50 Hz: 210 l/m, 12.6 m ³ /hr, 7.4 cfm
Ultimate pressure	1.3 x 10 ⁻² mbar (1 x 10 ⁻² Torr)
Maximum inlet pressure	1.0 atmosphere (1.0 psig)
Maximum outlet pressure	1.1 atmosphere (1.5 psig)
Inlet connection	NW25
Exhaust connection	¼" Female NPT with swivel (NW16 adapter provided)
Gas ballast	⅝" Female NPT (shipped with 40 micron filter installed; port plug also provided)
Operating voltages	1Ø models: 50-60 Hz/100-115:200-230 VAC 3Ø models: 50 Hz/200-230, 380-415 VAC; 60 Hz/200-230, 460 VAC
Weight	Pump only: 26.4 kg (58 lbs) Shipping weight: 34.2 kg (75 lbs)
Certification	CE, CSA and RoHS

NOTE: Scroll pumps are not suitable for pumping corrosive, explosive or particulate-forming gases.

DRY SCROLL PUMPS

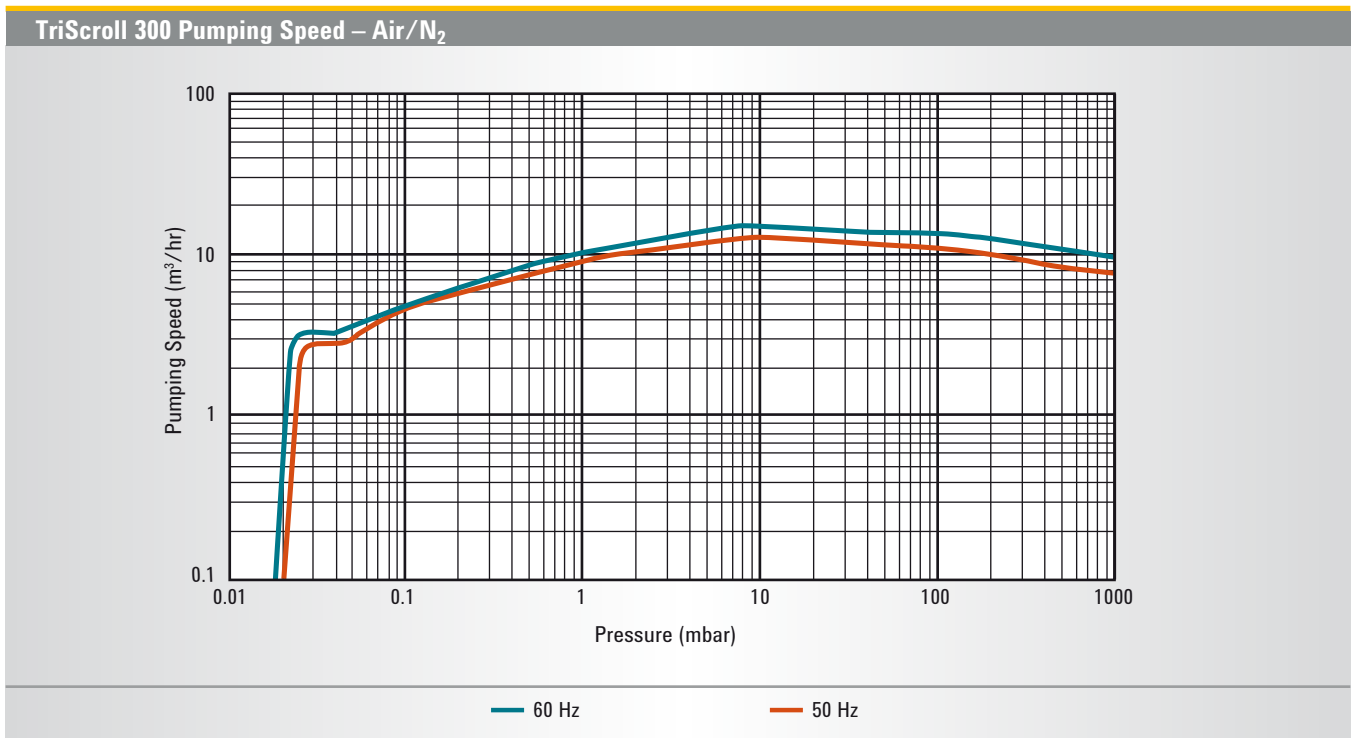

Ordering Information

Description	Part Number
TriScroll 300 dry vacuum pump, 1Ø motor, US cord	PTS03001UNIV
TriScroll 300 dry vacuum pump, 1Ø motor, Euro cord	PTS03001UNIVEU
TriScroll 300 dry vacuum pump, 1Ø motor, UK cord	PTS03001UNIVUK
TriScroll 300 dry vacuum pump, 3Ø motor	PTS03003UNIV
TriScroll 300, 1Ø, with vacuum isolation valve (VPI), 120 V	PTS03001UVPI*
TriScroll 300, 1Ø, with VPI, 220 V, EU power cord	PTS03001UVPIEU
TriScroll 300, 1Ø, with VPI, 220V, UK power cord	PTS03001UVPIUK
TriScroll 300, 3Ø, with VPI, 200 V	PTS03003200VPI
TriScroll 300, 3Ø, with VPI, 230 V	PTS03003230VPI
TriScroll 300, 3Ø, with VPI, 380/415 V	PTS03003380415VPI
TriScroll 300, 3Ø, with VPI, 460 V	PTS03003460VPI
TriScroll 300 exhaust extension	S4707002

* Contact Agilent for other voltages.

Accessories – Refer to the Scroll Accessories section beginning on page 27

Maintenance/Service Parts – Refer to the Scroll Service Parts section beginning on page 34