

PUMP MODELS

▶ Agilent SH-112

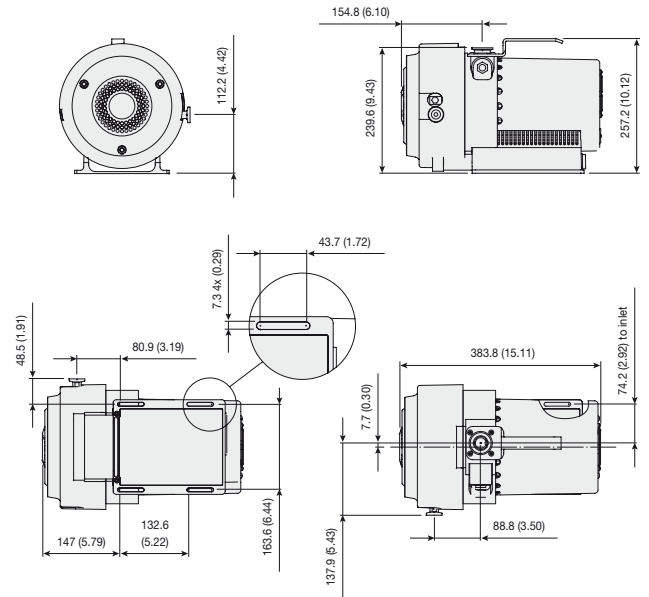

The Agilent SH-112 is a dry, hermetic scroll pump that provides industry-leading features designed for easy integration into original-equipment manufacturer (OEM) systems. This single-stage pump produces a pumping speed of 110 l/m and achieves an ultimate pressure of 200 mTorr (0.26 mbar) in a compact package that is also ideally suited to end-user applications.

- Solid tip seals for extended service interval
- Low-temperature operation
- ¼-horsepower motor for low power consumption
- Optional air ballast for effective handling of water vapor
- Built-in fail-safe isolation valve protects the vacuum system
- Universal 100-230 VAC power for easy installation worldwide
- Quick tip-seal replacement for low cost of ownership

Technical Specifications

Pumping speed	60 Hz: 110 l/m, 6.6 m ³ /hr, 4.0 cfm 50 Hz: 90 l/m, 5.4 m ³ /hr, 3.3 cfm
Ultimate pressure	2.6 x 10 ⁻¹ mbar (2.0 x 10 ⁻¹ Torr)
Maximum inlet pressure	1.0 atmosphere (0 psig)
Maximum outlet pressure	1.5 atmosphere (7.5 psig)
Inlet connection	NW25
Exhaust connection	¼" Female NPT (NW16 adapter provided)
Gas ballast	⅝" Female NPT (shipped with gas ballast port plug installed; 20 micron sintered filter provided)
Weight	Pump only: 19 kg (43 lbs) Shipping weight: 20 kg (44 lbs)
Leak rate (with exhaust sealed)	<1 x 10 ⁻⁷ cc/sec Helium
Certification	Conforms with CE, CSA and RoHS

NOTE: Scroll pumps are not suitable for pumping corrosive, explosive or particulate-forming gases.

DRY SCROLL PUMPS

SH-112 Pumping Speed - Air/N₂

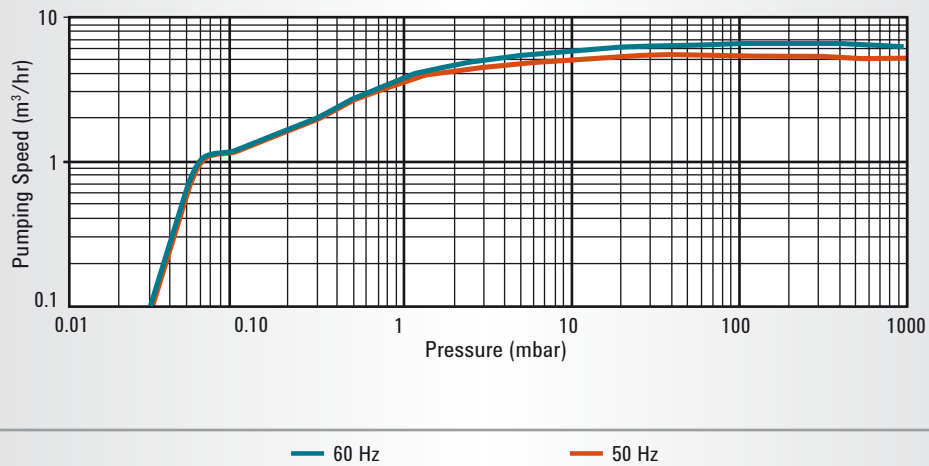

Ordering Information

Description	Part Number
SH-112 dry vacuum pump, 1Ø, 100 V - 230 V, 50/60 Hz	SH01121UNIV

Power Cord Selection	Part Number
Europe, 10 A / 220-230 V, 2.5 meter	656494220
Denmark, 10 A / 220-230 V, 2.5 meter	656494225
Switzerland, 10 A / 230 V, 2.5 meter	656494235
UK/Ireland, 13 A / 230 V, 2.5 meter	656494250
India, 10 A / 220-250 V, 2.5 meter	656494245
Israel, 10 A / 230 V, 2.5 meter	656494230
Japan, 12 A / 100 V, 2.3 meter	656494240
North America, 15 A / 125 V, 2.0 meter	656458203
North America, 10 A / 230 V, 2.5 meter	656494255

Accessories – Refer to the Scroll Accessories section beginning on page 27

Maintenance/Service Parts – Refer to the Scroll Service Parts section beginning on page 34