

PUMP MODELS

▶ Agilent IDP-3

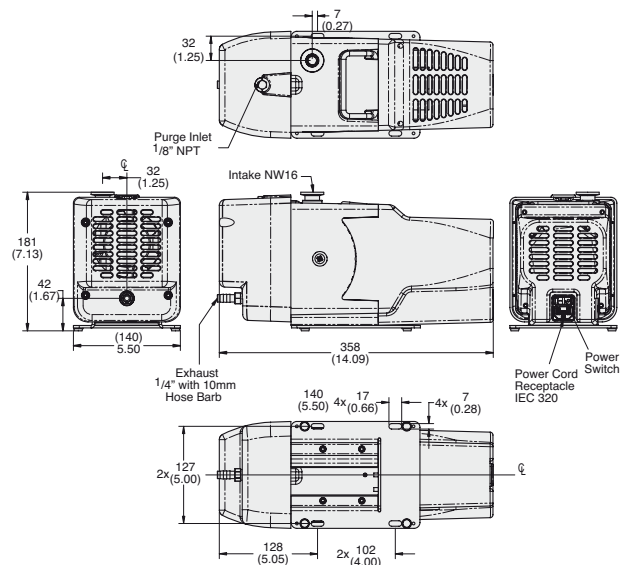

Dimensions: millimeters (inches)

The Agilent IDP-3 Dry Scroll Pump is an innovative, compact, high-performance, oil-free vacuum pump that is suitable for a wide variety of applications. It is the smallest scroll pump made for general vacuum applications, which makes it easy to integrate into OEM systems, and it weighs only 21 pounds (9.5 kg). Yet with a pumping speed of 60 l/m and a very low base pressure of 250 milliTorr, it is the highest-performing dry pump in its class.

- Oil-free - no contamination of the vacuum system
- Hermetic design with fully isolated motor and bearings
- Low noise and vibration
- No mechanisms subject to catastrophic failure
- Lower base pressure than diaphragm pumps
- Speed control on 24 VDC motor with 0-10V control signal
- Hour meter is standard on all IDP-3 units

Technical Specifications

Pumping speed	60 Hz: 60 l/m, 3.6 m ³ /hr, 2.1 cfm 50 Hz: 50 l/m, 3.0 m ³ /hr, 1.8 cfm
Ultimate pressure	2.5 x 10 ⁻¹ Torr (3.3 x 10 ⁻¹ mbar)
Maximum inlet pressure	1 atmosphere (0 psig)
Maximum outlet pressure	1.4 atmosphere (6.5 psig)
Inlet connection	NW16 flange
Exhaust connection	1/4" Female NPT (10 mm hose barb provided)
Gas ballast	1/8" Female NPT (shipped with gas ballast port plug installed; 20 micron sintered filter provided)
Weight	Pump only: 9.5 kg (21 lbs.) Shipping weight: 10.5 kg (23 lbs.)
Leak rate	<1 x 10 ⁻⁶ std-cc/sec helium
Certification	Conforms with CE, CSA, CSA/CUS, Semi S2-703, and RoHS

NOTE: Scroll pumps are not suitable for pumping corrosive, explosive or particulate-forming gases.

DRY SCROLL PUMPS

IDP-3 Pumping Speed - Air/N₂

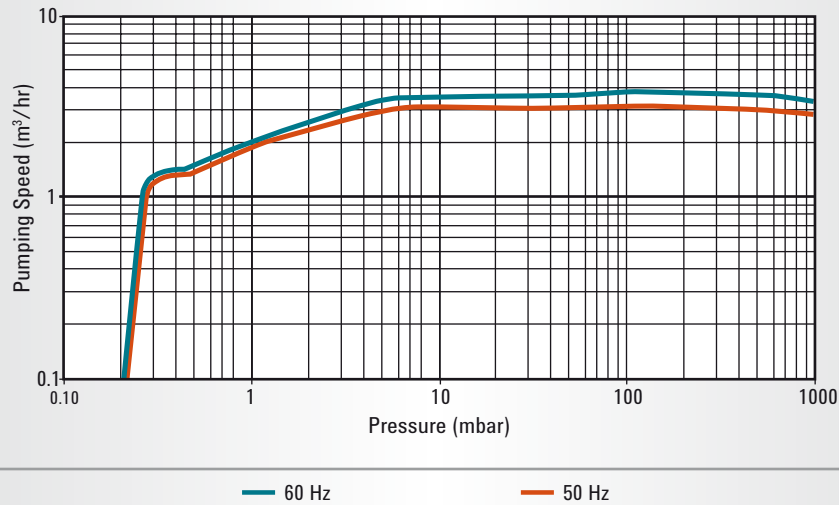

Ordering Information

Description	Part Number
IDP-3 dry vacuum pump, 1Ø, 220 V, 50/60 Hz	IDP3A01
IDP-3 dry vacuum pump, 1Ø, 115 V, 60 Hz	IDP3B01
IDP-3 dry vacuum pump, 1Ø, 100 V, 50/60 Hz	IDP3C01
IDP-3 dry vacuum pump, 24 VDC	IDP3D01

with Isolation Valve

IDP-3 dry vacuum pump with isolation valve, 1Ø, 220-230 V, 50/60 Hz	IDP3A21
IDP-3 dry vacuum pump with isolation valve, 1Ø, 115 V, 60 Hz	IDP3B21
IDP-3 dry vacuum pump with isolation valve, 1Ø, 100 V, 50/60 Hz	IDP3C21
IDP-3 dry vacuum pump with isolation valve, 24 VDC	IDP3D21

Power Cord Selection

Power Cord Selection	Part Number
Europe, 10 A / 220-230 V, 2.5 meter	656494220
Denmark, 10 A / 220-230 V, 2.5 meter	656494225
Switzerland, 10 A / 220-230 V, 2.5 meter	656494235
UK/Ireland, 13A / 230 V, 2.5 meter	656494250
India, 10 A / 220 - 250 V, 2.5 meter	656494245
Israel, 10 A / 230 V, 2.5 meter	656494230
Japan, 12 A/100 V, 2.3 meter	656494240
North America, 15 A / 125 V, 2.0 meter	656458203
North America, 10 A / 230 V, 2.5 meter	656494255

Accessories – Refer to the Scroll Accessories section beginning on page 27

Maintenance/Service Parts – Refer to the Scroll Service Parts section beginning on page 34