

Agilent IDP-10 Dry Scroll Vacuum Pump

Data Sheet

The Agilent IDP-10 dry scroll pump is a compact, high performance, oil-free vacuum pump that is easy to maintain. The inverter driven motor provides uniform vacuum performance at all global frequencies and input voltages.

The hermetic design, with the motor and all bearings completely isolated from the vacuum path extends the bearing life and provides clean, dry vacuum. An optional integral inlet protection valve, built into the pump module, is available and adds no additional height to the pump.

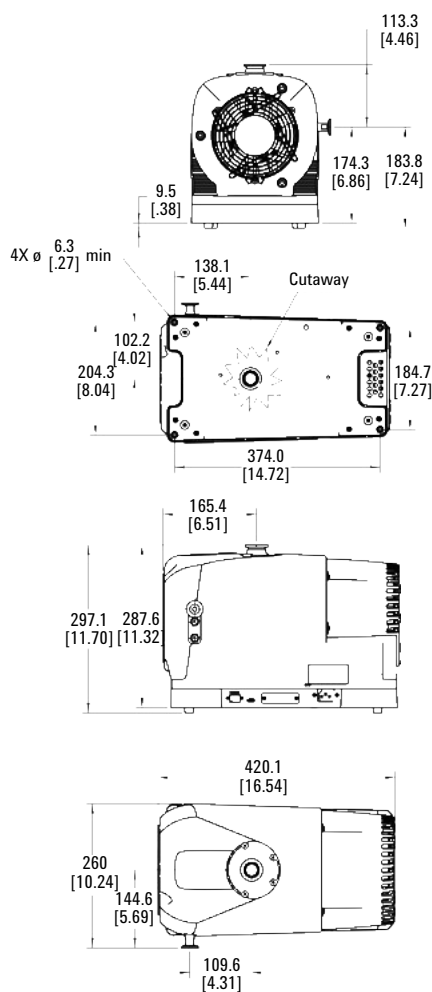

Dimensions: millimeters [inches]

Technical specifications

IDP-10 dry scroll single sided hermetic vacuum pump

Peak pumping speed	170 L/min, 10.2 m ³ /h at full speed
Media	No corrosive, explosive or particulate forming gases
Ultimate pressure	2.0 x 10 ⁻² mbar (1.5 x 10 ⁻² Torr)
Max. inlet pressure	1.0 atmosphere (0 psig)
Max. recommended continuous inlet pressure	2.0 x 10 ⁻² mbar (1.5 x 10 ⁻² Torr)
Max. outlet pressure at nom voltage	1.34 atmosphere (5 psig)
Inlet connection	NW25
Exhaust connection	NW16
Gas ballast	Female, 0.25 inch, national pipe thread, (20 μm sintered plug provided) SAE-2 5/16-24
Water vapor handling per Pneurop 6602	120 g/h maximum
Ambient operating temperature	5 to 40 °C (41 to 104 °F)
Storage temperature	-20 to 60 °C (-4 to 140 °F)
Motor rating	0.5 HP (350 W); 3ø inverter driven
Operating voltages	100-127; 200-240 VAC, 50/60 Hz
Motor thermal protection	Automatic thermal protection
Operating speed	45 Hz: 1350 rpm; 63.33 Hz: 1900 rpm
Cooling system	Air-cooled
Weight	Pump only: 24.74 kg (54.5 lbs), shipping weight: 28.1 kg (62 lbs)
Dimensions (H x W x L mm)	297 x 260 x 420
Leak rate (with exhaust sealed)	<1 x 10 ⁻⁶ sccs helium
Noise level	53 +/- 2 dB (A)
Vibration level at inlet	7 mms ⁻¹ rms
Hour meter	Integral hour meter provided
Emissions and immunity	EN 61236-1:2013 as a Class A device
Safety	EN/IEC 61010 3rd Edition certified



Agilent Technologies



Ordering information

IDP-10 dry scroll pumps and accessories

Description	Part number
IDP-10 dry scroll vacuum pump	X3810-64000
IDP-10 dry scroll vacuum pump with inlet isolation valve	X3810-64010
Service parts	
IDP-7 and IDP-10 tip seal replacement kit	X3807-67000
Accessory parts	
Exhaust silencer kit	X3807-68003
Purge kit	X3807-68004
Gas ballast kit	X3807-68008
Inlet trap	SCRINTRPNW25
Vibration isolation kit	SH110VIBISOKIT

Power cords for IDP-3 AC motor, IDP-7, IDP-10, and IDP-15 vacuum pumps

Description	Part number
Europe, 10 A/220-230 V, 2.5 m	656494220
Denmark, 10 A/220-230 V, 2.5 m	656494225
Switzerland, 10 A/230 V, 2.5 m	656494235
UK/Ireland, 13 A/230 V, 2.5 m	656494250
India, 10 A/220-250 V, 2.5 m	656494245
Israel, 10 A/220-230 V, 2.5 m	656494230
Japan, 12 A/100 V, 2.3 m	656494240
North America, 15 A/125 V, 2.0 m	656458203
North America, 10 A/230 V, 2.5 m	656494255

IDP-10 air/N₂ pumping speed

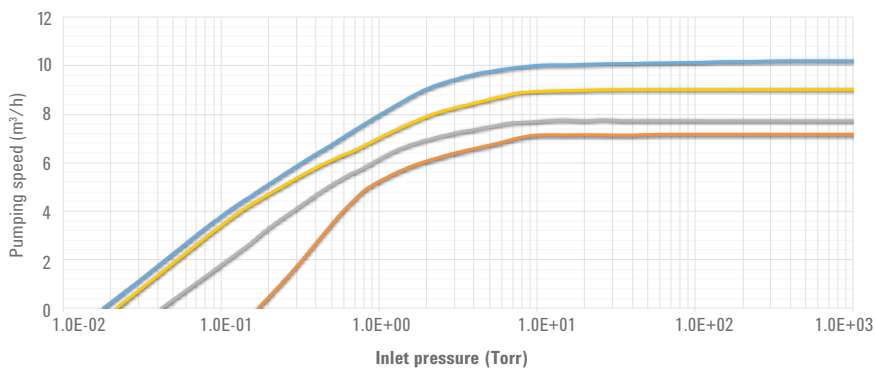

— 1900 rpm N₂ speed (m³/h) Factory set at 63.3 Hz
 — 1600 rpm N₂ speed (m³/h) (approximately 55 Hz)
 — 1450 rpm N₂ speed (m³/h) (approximately 50 Hz)
 — 1350 rpm N₂ speed (m³/h) (approximately 45 Hz)

North and South America

Agilent Technologies
 121 Hartwell Avenue, Lexington MA 02421, USA
 Tel: +1 781 861 7200
 Fax: +1 781 860 5437
 Toll free: +1 800 882 7426
vpl-customerservice@agilent.com

Europe and other countries

Agilent Technologies Italia SpA
 via F.lli Varian 54, 10040 Leini, (Torino), Italy
 Tel: +39 011 9979 111
 Fax: +39 011 9979 350
 Toll free: 00 800 234 234 00
vpt-customerservice@agilent.com

For Research Use Only.
 Not for use in diagnostic procedures.
 This information is subject to change without notice.

© Agilent Technologies, Inc. 2017
 Published in USA, January 19, 2017
 5991-7603EN