

MKS Baratron® Type 226B/228A Differential Pressure Transducers



Copyright © 2021 by MKS Instruments, Inc.

All rights reserved. No part of this work may be reproduced or transmitted in any form or by any means, electronic or mechanical, including photocopying and recording, or by any information storage or retrieval system, except as may be expressly permitted in writing by MKS Instruments, Inc.

Printed in the United States of America

mksinst™ is a trademark and Baratron® is a registered trademark of MKS Instruments, Inc., Andover, Massachusetts, USA.

Swagelok®, VCR®, VCO®, and Ultra-Torr® are registered trademarks of Swagelok Marketing Company, Solon, Ohio, USA

Inconel® is a registered trademark of Inco Alloys International, Inc., Huntington, West Virginia, USA.

Protected by U.S. Patent Numbers 4785669 and 5625152. Foreign patents pending.

Some Baratron® products may not be exported to many end user countries without both US and local government export licenses under ECCN 2B230.

Table of Contents

Safety Information.....	1
Symbols Used in This Instruction Manual	1
Symbols Found on the Unit	2
Safety Procedures and Precautions.....	3
Sicherheitshinweise für den Druckmeßumformer	5
In dieser Betriebsanleitung vorkommende Symbole.....	5
Erklärung der am Gerät angebrachten Symbole.....	6
Sicherheitsvorschriften und Vorsichtsmaßnahmen	7
Informations relatives à la sécurité pour le transducteur de pression.....	9
Symboles utilisés dans ce manuel d'utilisation.....	9
Symboles apparaissant sur l'unité.....	10
Mesures de sécurité et précautions	11
Medidas de seguridad del transductor de presión.....	13
Símbolos usados en este manual de instrucciones.....	13
Símbolos hallados en la unidad	14
Procedimientos y precauciones de seguridad	15
Chapter One: General Information	17
Introduction	17
How This Manual is Organized.....	18
Customer Support.....	18
Chapter Two: Installation	20
How To Unpack the Type 226B/228A Unit.....	20
Unpacking Checklist	20
Installation Requirements and Information	21
Electrical:.....	21
Pin Assignments:	21
Mounting:	23
Piping:.....	23

Performance Considerations:.....	24
Environmental:	24
Overpressure Considerations.....	24
Trip Point Adjustment	25
Chapter 3: Configurations.....	27
General Information.....	27
Sensor	27
Signal Conditioner.....	27
Trip Points	27
Chapter 4 - Operation	29
How To Zero the Type 226B/228A Transducer.....	29
How to Adjust the Zero Potentiometer.....	29
Chapter Five: Maintenance and Troubleshooting.....	31
General Maintenance	31
Troubleshooting.....	32
High, Low, or Erratic Output, or No Output at All	32
Returns.....	32
Appendix A: Model Number Configurations	35
Appendix B: Product Specifications.....	39
Physical Specifications	39
Performance Specifications	40
Environmental Specifications.....	40
Index	41

List of Figures and Tables

Figures

Figure 1 - The 226B/228A in the Normal Orientation	26
Figure 2 - Installation Dimensions of the 226B/228A Transducer	26

Tables

Table 1: Definition of Symbols Found on the Unit	2
Tabelle 2: Bedeutung der am Gerät angebrachten Symbole	6
Tableau 3: Définition des symboles apparaissant sur l'unité	10
Tabla 4: Definición de los símbolos hallados en la unidad	14
Table 5 - Pin Assignments of the Interface Connector on the Model 226B.....	22
Table 6 - Pin Assignments of the Interface Connector (J1) on the Model 228A.	23
Table 7 - Trip Point Jumper Settings.....	26
Table 9 - Ranges available for the Model 226B.....	35
Table 10 Fittings available for 226B/228A	36
Table 11 - Codes for Selecting Input and Output Type.....	37
Table 12 - Interface Connector Options for 226B/228A.....	38

Safety Information

Symbols Used in This Instruction Manual

Definitions of WARNING, CAUTION, and NOTE messages used throughout the manual.

Warning  The **WARNING** sign denotes a hazard. It calls attention to a procedure, practice, condition, or the like, which, if not correctly performed or adhered to, could result in injury to personnel.

Caution  The **CAUTION** sign denotes a hazard. It calls attention to an operating procedure, practice, or the like, which, if not correctly performed or adhered to, could result in damage to or destruction of all or part of the product.

Note  The **NOTE** sign denotes important information. It calls attention to a procedure, practice, condition, or the like, which is essential to highlight.

Symbols Found on the Unit

The following table describes symbols that may be found on the unit.





















Definition of Symbols Found on the Unit			
  IEC 417, No.5008	 Off (Supply) IEC 417, No.5008	  IEC 417, No.5008	 Protective earth (ground) IEC 417, No.5008
   IEC 417, No.5032	  IEC 417, No.5032	  IEC 417, No.5032	 Alternating current IEC 417, No.5032
 Both direct and alternating current IEC 417, No.5033-a	  IEC 617-2 No.020206	 Three phase alternating current IEC 617-2 No.020206	
 Caution, refer to accompanying documents ISO 3864, No.B.3.1	 Caution, risk of electric shock ISO 3864, No.B.3.6	 Caution, hot surface IEC 417, No.5041	

Table 1: Definition of Symbols Found on the Unit

Safety Procedures and Precautions

The following general safety precautions must be observed during all phases of operation of this instrument. Failure to comply with these precautions or with specific warnings elsewhere in this manual violates safety standards of intended use of the instrument and may impair the protection provided by the equipment. MKS Instruments, Inc. assumes no liability for the customer's failure to comply with these requirements.

DO NOT SUBSTITUTE PARTS OR MODIFY INSTRUMENT

Do not install substitute parts or perform any unauthorized modification to the instrument. Return the instrument to an MKS Calibration and Service Center for service and repair to ensure that all safety features are maintained.

SERVICE BY QUALIFIED PERSONNEL ONLY

Operating personnel must not remove instrument covers. Component replacement and internal adjustments must be made by qualified service personnel only.

DO NOT OPERATE IN EXPLOSIVE ATMOSPHERES

To avoid explosion, do not operate this product in an explosive atmosphere unless it has been specifically certified for such operation.

USE PROPER FITTINGS AND TIGHTENING PROCEDURES

All instrument fittings must be consistent with instrument specifications, and compatible with the intended use of the instrument. Assemble and tighten fittings according to manufacturer's directions.

CHECK FOR LEAK-TIGHT FITTINGS

Before proceeding to instrument setup, carefully check all plumbing connections to the instrument to ensure leak-tight installation.

OPERATE AT SAFE INLET PRESSURES

This unit should never be operated at pressures higher than the rated maximum pressure (refer to the product specifications for the maximum allowable pressure).

INSTALL A SUITABLE BURST DISC

When operating from a pressurized gas source, a suitable burst disc should be installed in the vacuum system to prevent system explosion should the system pressure rise.

KEEP THE UNIT FREE OF CONTAMINANTS

Do not allow contaminants of any kind to enter the unit before or during use. Contamination such as dust, dirt, lint, glass chips, and metal chips may permanently damage the unit.

Sicherheitshinweise für den Druckmeßumformer

In dieser Betriebsanleitung vorkommende Symbole

Bedeutung der mit WARNUNG!, VORSICHT! und HINWEIS gekennzeichneten Absätze in dieser Betriebsanleitung.

Warnung!



Das Symbol **WARNUNG!** weist auf eine Gefahr für das Bedienpersonal hin. Es macht auf einen Arbeitsablauf, eine Arbeitsweise, einen Zustand oder eine sonstige Gegebenheit aufmerksam, deren unsachgemäße Ausführung bzw. ungenügende Berücksichtigung zu Verletzungen führen kann.

Vorsicht!



Das Symbol **VORSICHT!** weist auf eine Gefahr für das Gerät hin. Es macht auf einen Bedienungsablauf, eine Arbeitsweise oder eine sonstige Gegebenheit aufmerksam, deren unsachgemäße Ausführung bzw. ungenügende Berücksichtigung zu einer Beschädigung oder Zerstörung des Gerätes oder von Teilen des Gerätes führen kann.

Hinweis



Das Symbol **HINWEIS** macht auf wichtige Informationen bezüglich eines Arbeitsablaufs, einer Arbeitsweise, eines Zustands oder einer sonstige Gegebenheit aufmerksam.

Erklärung der am Gerät angebrachten Symbole

Nachstehender Tabelle sind die Bedeutungen der Symbole zu entnehmen, die am Gerät angebracht sein können.















Bedeutung der am Gerät angebrachten Symbole			
			
Ein (Energie) IEC 417, No.5007	Aus (Energie) IEC 417, No.5008	Erdanschluß IEC 417, No.5017	Schutzleiteranschluß IEC 417, No.5019
			
Masseanschluß IEC 417, No.5020	Aquipotential- anschluß IEC 417, No.5021	Gleichstrom IEC 417, No.5031	Wechselstrom IEC 417, No.5032
			
Gleich- oder Wechselstrom IEC 417, No.5033-a	Durchgängige doppelte oder verstärkte Isolierung IEC 417, No.5172-a	Dreileiter- Wechselstrom (Drehstrom) IEC 617-2, No.020206	
			
Warnung vor einer Gefahrenstelle (Achtung, Dokumen- tation beachten) ISO 3864, No.B.3.1	Warnung vor gefährlicher elektrischer Spannung ISO 3864, No.B.3.6	Höhere Temperatur an leicht zugänglichen Teilen IEC 417, No.5041	

Tabelle 2: Bedeutung der am Gerät angebrachten Symbole

Sicherheitsvorschriften und Vorsichtsmaßnahmen

Folgende allgemeine Sicherheitsvorschriften sind während allen Betriebsphasen dieses Gerätes zu befolgen. Eine Mißachtung der Sicherheitsvorschriften und sonstiger Warnhinweise in dieser Betriebsanleitung verletzt die für dieses Gerät und seine Bedienung geltenden Sicherheitsstandards, und kann die Schutzvorrichtungen an diesem Gerät wirkungslos machen. MKS Instruments, Inc. haftet nicht für Mißachtung dieser Sicherheitsvorschriften seitens des Kunden.

Niemals Teile austauschen oder Änderungen am Gerät vornehmen!

Ersetzen Sie keine Teile mit baugleichen oder ähnlichen Teilen, und nehmen Sie keine eigenmächtigen Änderungen am Gerät vor. Schicken Sie das Gerät zwecks Wartung und Reparatur an den MKS-Kalibrierungs- und -Kundendienst ein. Nur so wird sichergestellt, daß alle Schutzvorrichtungen voll funktionsfähig bleiben.

Wartung nur durch qualifizierte Fachleute!

Das Auswechseln von Komponenten und das Vornehmen von internen Einstellungen darf nur von qualifizierten Fachleuten durchgeführt werden, niemals vom Bedienpersonal.

Vorsicht beim Arbeiten mit gefährlichen Stoffen!

Wenn gefährliche Stoffe verwendet werden, muß der Bediener die entsprechenden Sicherheitsvorschriften genauestens einhalten, das Gerät, falls erforderlich, vollständig spülen, sowie sicherstellen, daß der Gefahrstoff die am Gerät verwendeten Materialien, insbesondere Dichtungen, nicht angreift.

Spülen des Gerätes mit Gas!

Nach dem Installieren oder vor dem Ausbau aus einem System muß das Gerät unter Einsatz eines reinen Trockengases vollständig gespült werden, um alle Rückstände des Vorgängermediums zu entfernen.

Anweisungen zum Spülen des Gerätes

Das Gerät darf nur unter einer Ablufthaube gespült werden. Schutzhandschuhe sind zu tragen.

Gerät nicht zusammen mit explosiven Stoffen, Gasen oder Dämpfen benutzen!

Um der Gefahr einer Explosion vorzubeugen, darf dieses Gerät niemals zusammen mit (oder in der Nähe von) explosiven Stoffen aller Art eingesetzt werden, sofern es nicht ausdrücklich für diesen Zweck zugelassen ist.

Anweisungen zum Installieren der Armaturen!

Alle Anschlußstücke und Armaturenteile müssen mit der Gerätespezifikation übereinstimmen, und mit dem geplanten Einsatz des Gerätes kompatibel sein. Der Einbau, insbesondere das Anziehen und Abdichten, muß gemäß den Anweisungen des Herstellers vorgenommen werden.

Verbindungen auf Undichtigkeiten prüfen!

Überprüfen Sie sorgfältig alle Verbindungen der Vakuumkomponenten auf undichte Stellen.

Gerät nur unter zulässigen Anschlußdrücken betreiben!

Betreiben Sie das Gerät niemals unter Drücken, die den maximal zulässigen Druck (siehe Produktspezifikationen) übersteigen.

Geeignete Berstscheibe installieren!

Wenn mit einer unter Druck stehenden Gasquelle gearbeitet wird, sollte eine geeignete Berstscheibe in das Vakuumsystem installiert werden, um eine Explosionsgefahr aufgrund von steigendem Systemdruck zu vermeiden.

Verunreinigungen im Gerät vermeiden!

Stellen Sie sicher, daß Verunreinigungen jeglicher Art weder vor dem Einsatz noch während des Betriebs in das Instrumenteninnere gelangen können. Staub- und Schmutzpartikel, Glassplitter oder Metallspäne können das Gerät dauerhaft beschädigen oder Prozeß und Meßwerte verfälschen.

Bei Geräten mit Temperaturkontrolle korrekte Anwärmzeit einhalten!

Temperaturkontrollierte Geräte arbeiten nur dann gemäß ihrer Spezifikation, wenn genügend Zeit zum Erreichen und Stabilisieren der Betriebstemperatur eingeräumt wird. Kalibrierungen und Nulleinstellungen sollten daher nur nach Abschluß des Anwärmvorgangs durchgeführt werden.

Informations relatives à la sécurité pour le transducteur de pression

Symboles utilisés dans ce manuel d'utilisation

Définitions des indications AVERTISSEMENT, ATTENTION, et REMARQUE utilisées dans ce manuel.

Avertissement



L'indication **AVERTISSEMENT** signale un danger pour le personnel. Elle attire l'attention sur une procédure, une pratique, une condition, ou toute autre situation présentant un risque d'accident pour le personnel, en cas d'exécution incorrecte ou de non respect des consignes.

Attention



L'indication **ATTENTION** signale un danger pour l'appareil. Elle attire l'attention sur une procédure d'exploitation, une pratique, ou toute autre situation, présentant un risque d'endommagement ou de destruction d'une partie ou de la totalité de l'appareil, en cas d'exécution incorrecte ou de non respect des consignes.

Remarque



L'indication **REMARQUE** signale une information importante. Elle attire l'attention sur une procédure, une pratique, une condition, ou toute autre situation, présentant un intérêt particulier.

Symboles apparaissant sur l'unité

Le tableau suivant décrit les symboles pouvant apparaître sur l'unité.















Définition des symboles apparaissant sur l'unité			
			
Marche (sous tension) IEC 417, No.5007	Arrêt (hors tension) IEC 417, No.5008	Terre (masse) IEC 417, No.5017	Terre de protection (masse) IEC 417, No.5019
			
Masse IEC 417, No.5020	Equipotentialité IEC 417, No.5021	Courant continu IEC 417, No.5031	Courant alternatif IEC 417, No.5032
			
Courant continu et alternatif IEC 417, No.5033-a	Matériel de classe II IEC 417, No.5172-a	Courant alternatif triphase IEC 617-2, No.020206	
			
Attention : se reporter à la documentation ISO 3864, No.B.3.1	Attention : risque de choc électrique ISO 3864, No.B.3.6	Attention : surface brûlante IEC 417, No.5041	

Tableau 3: Définition des symboles apparaissant sur l'unité

Mesures de sécurité et précautions

Prendre les précautions générales de sécurité suivantes pendant toutes les phases d'exploitation de cet appareil. Le non respect des ces précautions ou des avertissements contenus dans ce manuel constitue une violation des normes de sécurité relatives à l'utilisation de l'appareil et peut diminuer la protection fournie par l'appareil. MKS Instruments, Inc. n'assume aucune responsabilité concernant le non respect des consignes par les clients.

PAS DE SUBSTITUTION DE PIÈCES OU DE MODIFICATION DE L'APPAREIL

Ne pas installer des pièces de substitution ou effectuer des modifications non autorisées sur l'appareil. Renvoyer l'appareil à un centre de service et de calibrage MKS pour tout dépannage ou réparation afin de garantir le l'intégrité des dispositifs de sécurité.

DÉPANNAGE UNIQUEMENT PAR DU PERSONNEL QUALIFIÉ

Le personnel d'exploitation ne doit pas essayer de remplacer des composants ou de faire des réglages internes. Tout dépannage doit être uniquement effectué par du personnel qualifié.

PRÉCAUTION EN CAS D'UTILISATION AVEC DES PRODUITS DANGEREUX

Si des produits dangereux sont utilisés, l'utilisateur est responsable de la prise des mesures de précaution appropriées, de la purge complète de l'appareil quand cela est nécessaire, et de la garantie que les produits utilisés sont compatibles avec les composants de cet appareil, y compris les matériaux d'étanchéité.

PURGE DE L'APPAREIL

Après l'installation de l'unité, ou avant son enlèvement d'un système, purger l'unité complètement avec un gaz propre et sec afin d'éliminer toute trace du produit de flux utilisé précédemment.

UTILISATION DES PROCÉDURES APPROPRIÉES POUR LA PURGE

Cet appareil doit être purgé sous une hotte de ventilation, et il faut porter des gants de protection.

PAS D'EXPLOITATION DANS UN ENVIRONNEMENT EXPLOSIF

Pour éviter toute explosion, ne pas utiliser cet appareil dans un environnement explosif, sauf en cas d'homologation spécifique pour une telle exploitation.

UTILISATION D'ÉQUIPEMENTS APPROPRIÉS ET PROCÉDURES DE SERRAGE

Tous les équipements de l'appareil doivent être cohérents avec ses spécifications, et compatibles avec l'utilisation prévue de l'appareil. Assembler et serrer les équipements conformément aux directives du fabricant.

VÉRIFICATION DE L'ÉTANCHÉITÉ DES CONNEXIONS

Vérifier attentivement toutes les connexions des composants pour le vide afin de garantir l'étanchéité de l'installation.

EXPLOITATION AVEC DES PRESSIONS D'ENTRÉE NON DANGEREUSES

Ne jamais utiliser des pressions supérieures à la pression nominale maximum (se reporter aux spécifications de l'unité pour la pression maximum admissible).

INSTALLATION D'UN DISQUE D'ÉCHAPPEMENT ADAPTÉ

En cas d'exploitation avec une source de gaz pressurisé, installer un disque d'échappement adapté dans le système à vide, afin d'éviter une explosion du système en cas d'augmentation de la pression.

MAINTIEN DE L'UNITÉ À L'ABRI DES CONTAMINATIONS

Ne pas laisser des produits contaminants pénétrer dans l'unité avant ou pendant l'utilisation. Des produits contaminants tels que des poussières et des fragments de tissu, de glace et de métal peuvent endommager l'unité d'une manière permanente ou contaminer le processus.

RESPECT DU TEMPS D'ÉCHAUFFEMENT APPROPRIÉ POUR LES UNITÉS À TEMPÉRATURE CONTRÔLÉE

Les unités à température contrôlée atteignent leurs spécifications uniquement quand on leur laisse un temps suffisant pour atteindre d'une manière stable la température d'exploitation. Ne pas remettre à zéro ou calibrer l'unité tant que l'échauffement n'est pas terminé.

Medidas de seguridad del transductor de presión

Símbolos usados en este manual de instrucciones

Definiciones de los mensajes de advertencia, precaución y de las notas usados en el manual.

Advertencia



El símbolo de advertencia indica la posibilidad de que se produzcan daños personales. **Pone de relieve un procedimiento, práctica, estado, etc. que en caso de no realizarse u observarse correctamente puede causar daños personales.**

Precaución



El símbolo de precaución indica la posibilidad de producir daños al equipo. **Pone de relieve un procedimiento operativo, práctica, estado, etc. que en caso de no realizarse u observarse correctamente puede causar daños o la destrucción total o parcial del equipo.**

Nota



El símbolo de notas indica información de importancia. Este símbolo pone de relieve un procedimiento, práctica o condición cuyo conocimiento es esencial destacar.

Símbolos hallados en la unidad

La tabla siguiente contiene los símbolos que puede hallar en la unidad.













Definición de los símbolos hallados en la unidad			
			
Encendido (alimentación eléctrica) IEC 417, N° 5007	Apagado (alimentación eléctrica) IEC 417, N° 5008	Puesta a tierra IEC 417, N° 5017	Protección a tierra IEC 417, N° 5019
			
Caja o chasis IEC 417, N° 5020	Equipotencialidad IEC 417, N° 5021	Corriente continua IEC 417, N° 5031	Corriente alterna IEC 417, N° 5032
			
Corriente continua y alterna IEC 417, N° 5033-a	Equipo de clase II IEC 417, N° 5172-a	Corriente alterna trifásica IEC 617-2, N° 020206	
			
Precaución. Consulte los documentos adjuntos ISO 3864, N° B.3.1	Precaución. Riesgo de descarga eléctrica ISO 3864, N° B.3.6	Precaución. Superficie caliente IEC 417, N° 5041	

Tabla 4: Definición de los símbolos hallados en la unidad

Procedimientos y precauciones de seguridad

Las precauciones generales de seguridad descritas a continuación deben observarse durante todas las etapas de funcionamiento del instrumento. La falta de cumplimiento de dichas precauciones o de las advertencias específicas a las que se hace referencia en el manual, constituye una violación de las normas de seguridad establecidas para el uso previsto del instrumento y podría anular la protección proporcionada por el equipo. Si el cliente no cumple dichas precauciones y advertencias, MKS Instruments, Inc. no asume responsabilidad legal alguna.

NO UTILICE PIEZAS NO ORIGINALES O MODIFIQUE EL INSTRUMENTO

No instale piezas que no sean originales ni modifique el instrumento sin autorización. Para asegurar el correcto funcionamiento de todos los dispositivos de seguridad, envíe el instrumento al Centro de servicio y calibración de MKS toda vez que sea necesario repararlo o efectuar tareas de mantenimiento.

LAS REPARACIONES DEBEN SER EFECTUADAS ÚNICAMENTE POR TÉCNICOS AUTORIZADOS

Los operarios no deben intentar reemplazar los componentes o realizar tareas de ajuste en el interior del instrumento. Las tareas de mantenimiento o reparación deben ser realizadas únicamente por personal autorizado.

TENGA CUIDADO CUANDO TRABAJE CON MATERIALES TÓXICOS

Cuando se utilicen materiales tóxicos, es responsabilidad de los operarios tomar las medidas de seguridad correspondientes, purgar totalmente el instrumento cuando sea necesario y comprobar que el material utilizado sea compatible con los materiales del instrumento e inclusive, con todos los materiales de sellado.

PURGUE EL INSTRUMENTO

Una vez instalada la unidad o antes de retirarla del sistema, purgue completamente la unidad con gas limpio y seco para eliminar todo resto de la sustancia líquida empleada anteriormente.

USE PROCEDIMIENTOS ADECUADOS PARA REALIZAR LA PURGA

El instrumento debe purgarse debajo de una campana de ventilación y deben utilizarse guantes protectores.

NO HAGA FUNCIONAR EL INSTRUMENTO EN AMBIENTES CON RIESGO DE EXPLOSIÓN

Para evitar que se produzcan explosiones, no haga funcionar este instrumento en un ambiente con riesgo de explosiones, excepto cuando el mismo haya sido certificado específicamente para tal uso.

USE ACCESORIOS ADECUADOS Y REALICE CORRECTAMENTE LOS PROCEDIMIENTOS DE AJUSTE

Todos los accesorios del instrumento deben cumplir las especificaciones del mismo y ser compatibles con el uso que se debe dar al instrumento. Arme y ajuste los accesorios de acuerdo con las instrucciones del fabricante.

COMPRUEBE QUE LAS CONEXIONES SEAN A PRUEBA DE FUGAS

Inspeccione cuidadosamente las conexiones de los componentes de vacío para comprobar que hayan sido instalados a prueba de fugas.

HAGA FUNCIONAR EL INSTRUMENTO CON PRESIONES DE ENTRADA SEGURAS

No haga funcionar nunca el instrumento con presiones superiores a la máxima presión nominal (en las especificaciones del instrumento hallará la presión máxima permitida).

INSTALE UNA CÁPSULA DE SEGURIDAD ADECUADA

Cuando el instrumento funcione con una fuente de gas presurizado, instale una cápsula de seguridad adecuada en el sistema de vacío para evitar que se produzcan explosiones cuando suba la presión del sistema.

MANTENGA LA UNIDAD LIBRE DE CONTAMINANTES

No permita el ingreso de contaminantes en la unidad antes o durante su uso. Los productos contaminantes tales como polvo, suciedad, pelusa, lascas de vidrio o virutas de metal pueden dañar irreparablemente la unidad o contaminar el proceso.

CALIENTE ADECUADAMENTE LAS UNIDADES CONTROLADAS POR MEDIO DE TEMPERATURA

Las unidades controladas por medio de temperatura funcionarán de acuerdo con las especificaciones sólo cuando se las caliente durante el tiempo suficiente para permitir que lleguen y se estabilicen a la temperatura de operación indicada. No calibre la unidad y no la ponga en cero hasta que finalice el procedimiento de calentamiento.

Chapter One: General Information

Introduction

Note



Some Baratron[®] products may not be exported to many end user countries without both US and local government export licenses under ECCN 2B230.

The MKS Baratron[®] Types 226B and 228A Differential Pressure Transducers¹ are part of the MKS family of general purpose pressure transducers designed to provide accurate, reliable and repeatable measurements of differential pressure ranges from 1000 to 0.2 Torr (100 to 0.02 kPa). These instruments have a precision capacitance based sensor² and self-contained signal conditioning electronics while keeping a small footprint.

The Types 226B/228A are the next generation of differential pressure transducer, designed to replace existing MKS models 223B, 225A, and 229H. Enhancements include improved EMI immunity for use around communications equipment, RoHS compliance, and new industrial design for better access to adjustments.

The 226B/228A pressure transducers can be powered by a DC power supply capable of providing the required voltages and current. Most commercial volt meters can be used to display the output. MKS models 660 and PR4000 can be used to both power the unit and display its output.

The 226B/228A transducers measure differential pressure, so the unit has two pressure ports. The transducer's output is proportional to the difference in input pressure between the two ports. When the process pressure (or 'Px' port) has a higher pressure than the reference pressure (on the 'Pr' port), the transducer produces a positive output signal. The transducer can also act as a gauge unit when the Pr port is left open to atmospheric pressure.

The 226B/228A can be ordered in a variety of power supply/output configurations. Voltage output signal units can be ordered to use either single (+24VDC) or dual (± 15 VDC) power supply. Voltage units are calibrated at the factory to 1, 5, or 10VDC output range. For all calibration types, voltage models produce an output of 0VDC at zero differential pressure. Current output signal units require +13 to +32VDC input voltage. Unidirectional current output units (also referred to as 4-20mA units) produce 4mA when the input pressure is zero, and 20mA when at full scale. Bidirectional current units output 4mA at negative full scale pressure, 12mA at zero pressure input, and 20mA at positive full scale.

When the input pressure goes beyond the range of the transducer the output continues to increase until the voltage saturates. In this over-range condition, the output will indicate changes in input pressure, but the accuracy is not guaranteed. The transducer is saturated when the output is at its highest (or lowest) value possible, and will no longer indicate changes in input pressure. Input pressures beyond the proof pressure of the transducer are not recommended, as they will cause a permanent shift in the calibration of the transducer.

Type 228A transducers contain two relays that provide trip point outputs in addition to the normal output signal. The trip point circuitry causes the associated relay to toggle when a designated

¹ U.S. Patent No. 5625152.

input pressure is reached. Both normally open and normally closed outputs are available for each trip point. Although the set point is adjusted to the customer's specification during assembly, there are customer accessible adjustments available to change the set points.

The 226B/228A transducer is designed for dry applications. Due to a durable Inconel® sensor design, the transducer can withstand up to 40 psi of line pressure (pressure common to both the Pr and Px ports). Furthermore, the transducer can withstand up to 20 psi of overpressure on the Px port.

How This Manual is Organized

This manual is designed to provide instructions on how to set up, install, and operate a Type 226B/228A unit.

Before installing your Type 226B/228A unit in a system and/or operating it, carefully read and familiarize yourself with all precautionary notes in the *Safety Messages and Procedures* section at the front of this manual. In addition, observe and obey all WARNING and CAUTION notes provided throughout the manual.

Chapter One, *General Information*, (this chapter) introduces the product and describes the organization of the manual.

Chapter Two, *Installation*, explains the environmental requirements and describes how to mount the instrument in your system and how to connect the wires.

Chapter Three, *Configurations*, gives a brief description of the instrument and how the various options work on the 226B/228A..

Chapter Four, *Operation*, describes how to use the 226B/228A unit while in operation..

Chapter Five, *Maintenance and Troubleshooting*, provides a few maintenance recommendations and a brief troubleshooting section. The Type 226B/228A transducer is highly reliable and requires little maintenance.

Appendix A, *Product Specifications*, lists the specifications of the instrument.

Appendix B, *Model Code Explanation*, describes the model code.

Customer Support

Standard maintenance and repair services are available at all of our regional MKS Calibration and Service Centers, listed on the back cover. In addition, MKS accepts the instruments of other manufacturers for recalibration using the Primary and Transfer Standard calibration equipment located at all of our regional service centers. Should any difficulties arise in the use of your Type 226B/228A instrument, or to obtain information about companion products MKS offers, contact any authorized MKS Calibration and Service Center. If it is necessary to return the instrument to MKS, please obtain an RMA Number (Return Material Authorization Number) from the MKS Calibration and Service Center before shipping. The RMA Number expedites handling and ensures proper servicing of your instrument.

Please refer to the inside of the back cover of this manual for a list of MKS Calibration and Service Centers. The MKS RMA website can be found at:
<http://www.mksinst.com/service/serviceeraform.aspx>

Warning



All returns to MKS Instruments must be free of harmful, corrosive, radioactive, or toxic materials.

Chapter Two: Installation

How To Unpack the Type 226B/228A Unit

MKS has carefully packed the Type 226B/228A unit so that it will reach you in perfect operating order. Upon receiving the unit, however, you should check for defects, cracks, broken connectors, etc., to be certain that damage has not occurred during shipment.

Note

Do *not* discard any packing materials until you have completed your inspection and are sure the unit arrived safely.

If you find any damage, notify your carrier and MKS immediately. If it is necessary to return the unit to MKS, obtain an RMA Number (Return Material Authorization Number) from the MKS Service Center before shipping. Please refer to the inside of the back cover of this manual for a list of MKS Calibration and Service Centers.

Caution

Only qualified individuals should perform the installation and any user adjustments. They must comply with all the necessary ESD and handling precautions while installing and adjusting the instrument. Proper handling is essential when working with all highly sensitive precision electronic instruments.

Unpacking Checklist

Standard Equipment:

- Type 226B/228A Unit

Optional Equipment:

- Several models of MKS power supply/readouts

Installation Requirements and Information

Electrical:

- Supply Voltage: ± 15 VDC ($\pm 5\%$) or +13 to +30VDC, depending on model.
- Supply Current: 25 milliamps maximum.
- Electrical Connector: All 226B transducers have a 9-pin D-subminiature connector, and 228A transducers use a 15-pin high-density D-subminiature connector. Optionally, the unit may also have a cable or terminal block adapter. The terminal block adapter is not recommended for new designs, as the unshielded conductors adversely affect the EMI immunity. See below for the complete list of pin assignments for the Interface connector.
- Maintain a solid system ground for proper operation and safety to personnel. A shielded, multi-conductor cable should be used in conjunction with D-subminiature connector with conductive shield. Proper shielding will ensure the best EMI immunity performance possible.

Pin Assignments:

- The pin assignments of the D-subminiature connector depend on the transducer model purchased. Model 226B transducers have different pin assignments depending on the output signal type, voltage or 4-20mA. Refer to Tables 5 and 6 below (colors are for flying lead version):

Table 5 - Pin Assignments of the 9-pin D-Subminiature and Terminal Block Connector on the Model 226B.

226B Pinout Assignments of 9-pin D-Subminiature and Terminal Block Connectors (J1)						
Pin/Post Number	Voltage output w/ +24 volt excitation		Voltage output w/ ±15 volt excitation		Current output	
1	Red	Pressure Signal	Red	Pressure Signal		Reserved
2		Reserved		Reserved		Reserved
3		Reserved		Reserved		Reserved
4	Green	+ Power Input	Green	+ Power Input	Green	+ Excitation
5		Reserved		Reserved		Reserved
6		Reserved	White	- Power Input		Reserved
7	Blue	Chassis Ground	Blue	Chassis Ground	Bare	Chassis Ground
8	Black	Pressure Return	Black	Pressure Return		Reserved
9	Orange	Power Ground	Orange	Power Ground	White	- Excitation

- Model 228A transducers are all voltage output, so there is only one type of pin assignment:

Pin Number	Color on Flying Lead	Function
1	Grey	Relay A, Normally Open
2	Red	Pressure Output Signal
3	Tan	Relay A Common
4	Yellow	Relay A, Normally Closed
5	Orange	Power Ground
6	White	- Power Supply Input
7	Green	+ Power Supply Input
8	Violet	Relay B Normally Open
9	Blue	Relay B Common
10	Brown	Relay B Normally Closed
11	N/A	Trip Point Adjust Common
12	Black	Pressure Return
13	N/A	Trip Point A Adjust
14	N/A	Trip Point B Adjust
15	Bare	Chassis Ground

Table 6 - Pin Assignments of the Interface Connector (J1) on the Model 228A.

Note: Connections marked Reserved should not have anything connected to them.

Mounting:

- The preferred orientation of the transducer is with the pressure port tubes horizontal (see Figure 1 - The 226B/228A in the Normal Orientation) although the 226B/228A can be mounted in any orientation.
- Secure the body of the transducer, either through one of the pressure port fittings, or using a mounting bracket.
- Isolate the unit from vibration. The diaphragm may be susceptible to resonance when there is not enough gas present to dampen the effects of vibration. Products with the 0.2 Torr (0.02 kPa) full scale range are the most sensitive to vibrations. Any vibration that *does* exist should be isolated from the unit with vibration isolation mounting and a flexible pressure coupling.
- Ensure adequate room to maintain environmental requirements and safety considerations, and to provide easy access for zeroing.
- Take care not to apply stress onto the pressure ports. Welding metal piping directly onto both pressure ports can cause excessive stress on the pressure sensor and negatively affect the accuracy and stability of the transducer.

Caution



Do not use single or double metal ferrule compression fittings on the port tubes. These fittings are commonly tightened incorrectly, causing damage to the pressure sensor.

Piping:

- Take care to prevent line pressure from being applied to a single side of the transducer in cases where line pressure is higher than the proof pressure of the unit. This can be accomplished by placing a valve between the two ports which is opened when initially applying line pressure to the unit, and closed for normal operation.
- Position a line tap above or to the side of the process line, and position the sensor above the line tap. This allows any liquids which may be present to drain into the process line.
- Install the interconnecting piping so that it slopes *away from* the sensor to the process line. A slope of 1 inch per foot (8 centimeters per meter) is adequate.
- Purge the interconnecting piping (close to the process tap) when needed to prevent sediment buildup. When purging, be sure to isolate the sensor from the interconnecting piping.
- Contamination (moisture and dirt) may affect the stability and sensitivity of the sensor, particularly in the Pr side, as this side contains the sensing electrode. Vapor condensation can be removed by evacuating both the Pr and Px cavities using a mechanical vacuum pump.

Warming the sensor (no higher than 60°C) may also help remove moisture. If contamination (particles) is expected, suitable traps or filters should be used. Once a sensor is contaminated with particles (dirt) sensor replacement is usually necessary.

- Special Note for 1/4" (6.3 mm) Tubing: The standard tubing for the 226B/228A transducer is straight 1/4" (6.3 mm) tubing. To connect the 226B/228A transducer to a Swagelok® Ultra-Torr® compression fitting:
 1. Ensure the tubing is clean and free of axial scratches.
 2. Insert the tubing through the compression nut and O-ring all the way to the fitting's shoulder.
 3. Tighten the nut.

Performance Considerations:

- Warmup time: 30 minutes.
- Overpressure limits: 20 psia or 120% of sensor full scale, whichever is greater on the Px port, and maximum 120% of sensor full scale on the Pr port.
- The transducer must be zeroed after installation.

Environmental:

- Storage Humidity Range: 25% to 95% relative humidity, non-condensing
- Storage Temperature Range: -20° to +80° C (-4° to 176° F)

Note



The maximum temperature specification is provided for general guidance under ideal conditions. If the switch is located in an enclosed environment or where air flow is limited or impeded in any way please consult your local MKS office for additional guidance.

Overpressure Considerations

As with any transducer, the 226B/228A transducer performs valid measurements up to the unit's Full Scale. At pressures of about 10% over Full Scale, the output signal saturates (i.e. stops rising) to warn of invalid readings. At pressures of more than 110% of the Full-Scale range, the diaphragm touches the fixed capacitor plate. The capacitor plate serves as a protective overpressure stop to prevent damage to the diaphragm up to 20 psi (except 1000 torr units, which may be over pressured to 23 psi). On a standard 226B/228A, there is no negative overpressure stop so the unit can be damaged by negative pressures of 120% of full scale.

Trip Point Adjustment

All Type 228A units have two separate internal relays that toggle at a particular pressure set point. Both the normally open (N.O.) and the normally closed (N.C.) contacts of the relay are available for customer use. The pressure at which the relays are toggled is adjustable from 0 to 100% of full range. The value is adjusted at MKS Instruments to 50% of full scale, unless arrangements have been made with MKS customer service for an alternate factory setting.

The set point can also be adjusted in the field using a small screwdriver. Just to the left of the electrical connector is the trip point interface. There are two lights that indicate the current status of the relay, and two screw adjustments for setting the pressure at which the relays toggle. Two common methods for adjusting the set point are:

- 1) Set the input pressure to the desired value, and then adjust the setpoint until the relay toggles. Keep in mind that the potentiometer has 12 turns of adjustment range. Also note that there is 30mV of hysteresis in the relay circuit, meaning that the trip point is slightly different depending on whether the pressure is rising or falling, which is required to eliminate relay chatter.
- 2) Use the set point adjust signal on the electrical connector (listed in Table 6). There is one output for each trip point circuit. These voltage signals show the pressure signal voltage at which the relays toggle. As the set point potentiometer is adjusted, the corresponding adjustment signal voltage will change. To properly adjust the potentiometer, first calculate the pressure signal voltage that corresponds to the desired trip point pressure, then adjust the set point adjust signal to match.

The trip points can also be adjusted to energize above or below the set point. This is important when considering the fail safe condition of the circuit in case the transducer loses power. This setting is adjusted by moving a jumper on a header on the upper circuit board in the transducer. First remove the top cover of the transducer by taking off both of the jack screws. Find JP4 and JP5, two 3 pin headers adjacent to the potentiometers.

	Set Point A JP4	Set Point B, JP5
Relay energized above the set point	1-2	1-2
Relay energized below the set point	2-3	2-3

Table 6 - Trip Point Jumper Settings

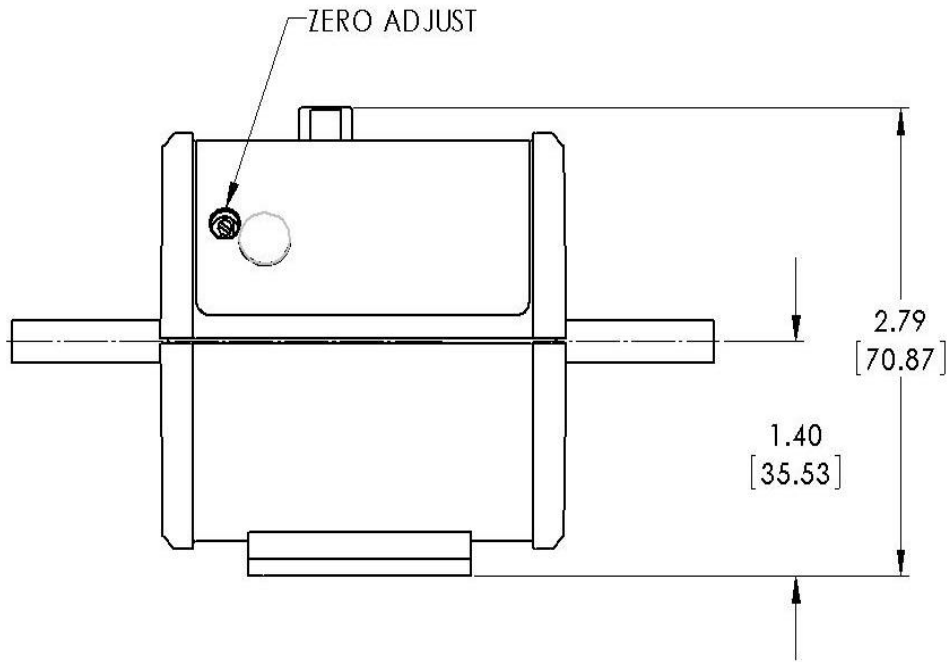

Figure 1 - The 226B/228A in the Normal Orientation

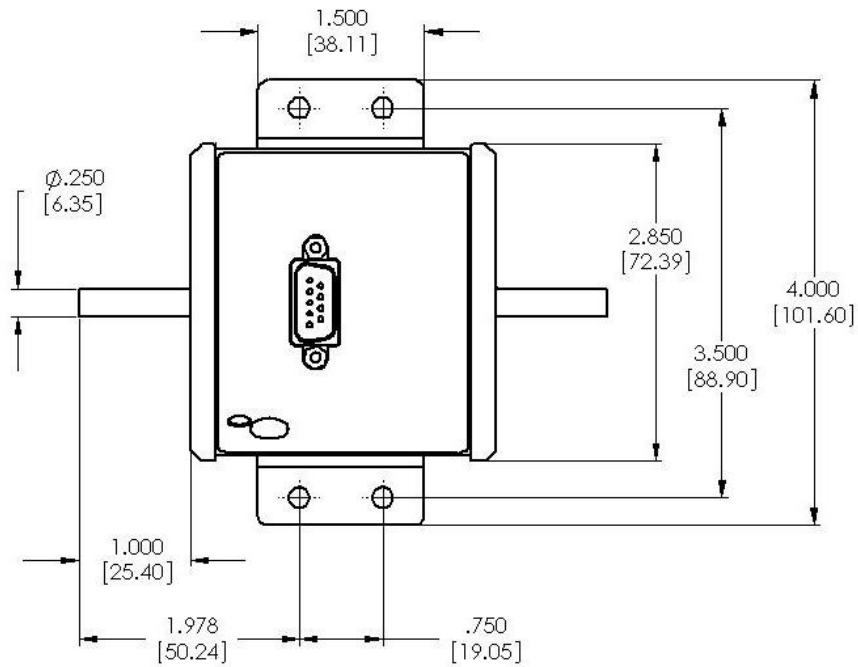

Figure 2 - Installation Dimensions of the 226B/228A Transducer

Chapter 3: Configurations

General Information

The Type 226B/228A pressure transducer is used to measure the difference between two pressure sources. Typical applications include measuring air flow through a venturi or other restriction and as a safety lockout device when handling hazardous gases. The model 226B transducer contains two elements: a differential pressure sensor and signal conditioning electronics. The model 228A contains additional trip point circuitry.

Sensor

The sensor uses a variable capacitor design that changes output based on the difference in pressure across a diaphragm. In this design, a capacitance electrode is positioned close to a tensioned Inconel[®] diaphragm. The diaphragm divides the sensor into two cavities; the reference pressure side, or simply 'Pr' (the side with the electrode), and measurement, or 'Px,' side. One pressure port on the sensor leads to the Pr side, and the other to the Px.

The diaphragm deflects with changing pressure—force per unit area—independent of the composition of the measured gas. This deflection causes a capacitance change between the diaphragm and the adjacent electrode assembly. A lead wire goes from the electrode to the circuit board, where the capacitance is measured and conditioned into a high level output signal.

Signal Conditioner

The signal conditioner contains “state-of-the-art” low impedance balanced bridge circuitry to measure the capacitance of the sensor. Signal conditioning compensates for the effects of ambient temperature changes, and linearizes the signal. The adjustments for span and zero are available to the customer, although span adjustment is not recommended unless the customer has access to a precision pressure standard.

Trip Points

The model 228A also contains two trip points, labeled 'A' and 'B.' The trip point circuitry uses the pressure signal to control a relay that provides an ON/OFF signal to the customer. Both the normally open and normally closed terminals of the relays are available for customer use. The pressure at which the relay trips is preset at the factory, but is customer adjustable. The trip points effectively make the 228A a differential pressure switch; a typical application is safeguarding personnel from dangerous gases.

The standard 228A is configured to have the relays de-energized when the output is below its setpoint. If it is important that a safety be kept on during a power interruption, care should be

taken to ensure the safe condition is selected when the relay is de-energized. The behavior of each trip point can be selected depending on customer needs by changing a jumper on the trip point circuit board.

See Appendix B for a full break-down of the model codes.

Chapter 4 - Operation

How To Zero the Type 226B/228A Transducer

MKS pressure transducers are precision measuring instruments, and will require initial and periodic zero adjustments. Prior to initial operation and during periodic maintenance, you must check the transducer zero to verify the proper output. The zero can be set (or reset) by adjusting the zero potentiometer located on the top of the transducer (refer to How to Adjust the Zero Potentiometer, page 29).

To achieve the full dynamic range specified for the transducer, the zero adjustment *must* be made while the input pressure matches the reference pressure. Even small air currents can affect the pressure input to the unit; it is suggested the pressure ports be plumbed together while zeroing the unit either using the installation plumbing or a flexible tube.

MKS does not recommend that customers change the span of any Type 226B/228A, since this requires access to an appropriate reference standard and specialized pressure control equipment. Please contact MKS Customer service if you need the transducer recalibrated.

How to Adjust the Zero Potentiometer

1. Install the transducer as described in Chapter 2, Installation.
2. Power the transducer and allow it to warm up and stabilize.

Note



Allow 30 minutes for units to warm up. Ensure that the transducer is *fully stabilized* before you adjust the zero.

3. Connect the two pressure ports together to ensure the differential pressure is zero.
4. Adjust the ZERO potentiometer with a small screwdriver until the readout displays zero (0.000). Hold the screwdriver parallel with the top surface of the unit.

This page intentionally left blank.

Chapter Five: Maintenance and Troubleshooting

General Maintenance

For best accuracy and repeatability, MKS recommends that you:

- Zero the unit regularly
Follow the procedure described in How To Zero the Type 226B/228A Transducer, page 29, on a regular basis.
- Schedule re-calibration annually
Follow an annual recalibration schedule, if no other time interval has been specifically established.
- Periodically check for wear on the cables and inspect the enclosure for visible signs of damage

Troubleshooting

High, Low, or Erratic Output, or No Output at All

Check the Interconnecting Piping

- Be sure there are no leaks or blockage in the interconnecting piping.
- Look for sediment or liquids in the sensor process connection(s).

Remove the contamination by purging the connection(s) with a solvent appropriate for your process.

Caution



Damage may occur to the sensor if the sediment is removed with a harsh solvent, or by scraping. Therefore:

- **Do not scrape the inside of the process connection(s).**
- **Only clean the process connection(s) with solvent appropriate for your process.**

Caution



Never put liquids or particles into the Pr side of the sensor. This will shift the calibration of the unit, or damage it permanently

Check the Wiring

- Ensure that the transducer is receiving the proper voltage.
- Verify that the total current being drawn by the system is within the specifications of the power supply.
- Check the signal terminals for the correct polarity.
- Measure the loop impedance.
- Look for shorts, multiple grounds, and defective wire insulation.

Returns

If the solutions presented in this chapter fail to resolve the problem, return the transducer to MKS for servicing. When returning the instrument to MKS, please obtain an RMA Number (Return Material Authorization Number) from the MKS Calibration and Service Center before shipping. The RMA Number expedites handling and ensures proper servicing of your instrument. See page 19 for the RMA website address.

Refer to the inside of the back cover of this instruction manual for a complete list of MKS Calibration and Service centers.

Warning



All returns to MKS Instruments must be free of harmful, corrosive, radioactive, or toxic materials.

This page left intentionally blank

Appendix A: Model Number Configurations

226B/228A options are selected when ordering the unit using a configurable part number system. The configurable part number fields are as follows:

226B RRR SS TT U VV W X

or:

228A RRR SS TT U VV W X YY

where each of the letters is explained below.

226B : All 226B units have this prefix.

RRR : Range

The range of the sensor determines the input pressures over which the transducer's output will accurate. The pressure range can be specified in a number of units:

Ranges (RRR)	Torr/mm Hg	mbar	kPa	in H ₂ O	cm H ₂ O
0.02	-	-	U2K	-	-
0.1	-	-	.1K	.1W	-
0.2	.2T	.2M	.2K	-	.2R
0.5	-	-	.5K	.5W	-
1	01T	01M	01K	01W	01R
2	02T	02M	02K	02W	02R
5	05T	05M	05K	05W	05R
10	11T	11M	11K	11W	11R
20	21T	21M	21K	21W	21R
50	51T	51M	-	51W	51R
100	12T	12M	12K	12W	12R
200	22T	22M	-	-	22R
500	-	-	-	52W	-
1000	13T	13M	-	-	13R

Table 7 - Ranges available for the Model 226B

Additional pressure ranges may have been created since this table was developed; see your MKS account representative or contact MKS Applications Group for more information.

SS : Pr port fitting

TT : Px port fitting

Each of the ports can accept a fitting. The 226B/228A transducer comes standard with 1/4" tube pressure ports. The following fittings are available for the Type 226B/228A transducer:

Code:	Fitting:
BB	1/4" Tube
BG	3/16" Tube
CB	Male 4 VCR
CD	Female 4 VCR
DC	Male 4 VCO
DD	Female 4 VCO
FA	Female 1/4" NPT
FB	Male 1/4" NPT
FE	Male 1/8" NPT
FF	Female 1/8" NPT
GA	NW 16-KF
HA	1.33" O.D. Conflat

Table 8 Fittings available for 226B/228A

U : ACCURACY:

The standard model 226B/228A has an accuracy of 0.5% of full scale and an accuracy code of 'F.' If required, the transducer can be calibrated to 0.5% of reading by using accuracy code 'K.' The highest level of accuracy, 0.3% of reading, can only be ordered for unidirectional units, and uses accuracy code 'S.'

VV : INPUT/OUTPUT TYPE:

The 226B/228A can be ordered with a variety of different output signals. For units that produce a voltage output signal, the full range signal can be selected to be 1, 5 or 10VDC. In addition, the calibration can be unidirectional or bidirectional. Unidirectional units are optimized for positive pressures only (when the Px pressure is higher than the Pr), whereas bidirectional units are calibrated for accuracy over both positive and negative pressures.

Units that give a current signal always have an output signal between 4 and 20mA. For unidirectional current units, the output will be 4mA when the Pr and Px pressures are the same, whereas for bidirectional units the output will be 12mA (midway between 4 and 20mA).

The 4-20mA transducers are powered by applying +13 to +32 VDC across the terminals. The voltage output version can be configured to be powered by either a single supply (nominally 24VDC) or dual supplies of +/-15VDC. Note that single power supply voltage units (+24VDC input) cannot have +10VDC output, either bidirectional or unidirectional. Table 9 shows all the options available:

Code	Function:
U1	+/-15VDC input, +1VDC output with unidirectional calibration
B1	+/-15VDC input, +1VDC output with bidirectional calibration
U2	+/-15VDC input, +10VDC output with unidirectional calibration
B2	+/-15VDC input, +10VDC output with bidirectional calibration
U3	+/-15VDC input, +5VDC output with unidirectional calibration
B3	+/-15VDC input, +5VDC output with bidirectional calibration
U4	+13-32VDC input, 4-20mA output with unidirectional calibration
B4	+13-32VDC input, 4-20mA output with bidirectional calibration
U5	+24VDC input, +1VDC output with unidirectional calibration
B5	+24VDC input, +1VDC output with bidirectional calibration
U7	+24VDC input, +5VDC output with unidirectional calibration
B7	+24VDC input, +5VDC output with bidirectional calibration

Table 9 - Codes for Selecting Input and Output Type

W : INTERFACE CONNECTOR:

The Interface connector J1 on a 226B transducer is a 9-pin male D-subminiature connector, and on the 228A transducer a 15-pin male type high density D-subminiature connector is standard. Refer to Figure 1 - The 226B/228A in the Normal Orientation, page 26, for the location of the Interface connector. The connector contains pins for powering the unit and the output signal(s). The function of each pin is described in **Error! Reference source not found.** and Table .

There are optional electrical connectors available for the Type 226B. MKS can supply a 10 ft (3 m) flying lead cable: one end has a D-subminiature connector and is plugged directly into the transducer, and the other end has bare wires stripped and tinned. Also, for the **Type 226B** only, an optional terminal block adapter is available for easy connection of stripped wires to the transducer.

Code	Connector	Available on
A	9 pin d-sub	226B
T	Terminal block adapter	226B
L	Flying lead adapter	226B
C	High density 15 pin D-subminiature	228A

Table 10 - Interface Connector Options for 226B/228A

X : MOUNTING BRACKET:

Two mounting brackets are available for mounting the transducer to a panel. The '0' code means no bracket, the '1' code indicates a mounting bracket with the same mounting dimensions as the Type 223B/225A/229A differential transducers, and the "2" code specifies a bracket with slotted mounting holes. For mounting dimensions, see Figure 2 - Installation Dimensions of the 226B/228A Transducer

YY : TRIP POINT SETTINGS:

The trip point settings are factory adjusted to 50% of full scale. An 'A' value in this field cause the relay to be set to energize above the setpoint, whereas a 'B' is for energized below the setpoint. The first Y position represents trip point A, and the second is for trip point B. In cases where the customer desires to have the set point preset to a value other than 50% of full scale, a custom sequential code will be created for these model code positions.

Appendix B: Product Specifications

Physical Specifications

Dimensions ²	2.46" height(2.8" with mounting bracket), 2.72" length, (6.3 cm height, 6.8 cm length)
Fittings	¼" tube (standard), 3/16" tube, male or female 4 VCR, male or female 4 VCO, male or female ¼" and 1/8" NPT, NW 16-KF, 1.33" CF
Full Scale Ranges	0.2, 1, 5, 10, 20, 50, 100, 200, 1000 mmHg (Torr) For other ranges, consult factory
Input Required Voltage Output Versions: Dual power supply Single power supply 4-20mA Output Version	±15 VDC ±5% @ 25mA maximum +24 VDC nominal (+13 to +32VDC) @ 25mA max +13 to +32 VDC @ 25mA maximum
Material Exposed to Gases (P _x port)	Inconel. Some optional fittings may be built from 300-series stainless steel.
Materials Exposed to Gases (P _r port)	Inconel, ceramic, palladium, stainless steel, sealing glass. Some optional fittings may be built from 300-series stainless steel.
Number of Decades of Resolution	4
Output (linear with pressure)	0 to 10VDC, -10 to 10VDC (±15VDC input voltage only), 0 to 5VDC, -5 to 5VDC, 0 to 1VDC, -1 to 1VDC, or 4 to 20mA; configured to order
Overpressure Limit, Positive pressure	120% of F.S. or 20 psia, whichever is greater
Overpressure Limit, Negative pressure	120% of F.S.
Type of Measurement	Differential pressure
Weight	1.2 lbs (0.5 kg)

² Dimensions do not include the external connector and tubulation.

Performance Specifications

Accuracy ³	Standard: ± 0.5% of Full Scale (all calibrations) Optional: ± 0.3% of Full Scale (all calibrations) ± 0.3% of Reading (unidirectional calibrations only)
Compliance	CE
Safety Certification	SEMI S2-0706, EN 61010-1:2001 (TÜV America)
Temperature Coefficients	
Zero (.5% of FS Accuracy Units)	0.1% F.S./°C
(.3% of FS Accuracy Units)	0.05% F.S./°C
(.3% of Reading Units)	0.02% of Reading/°C
Span	0.04% of Reading/°C

Environmental Specifications

Ambient Operating Temperature Range	0° to 50° C (32° to 122° F)
Storage Humidity Range	25 to 95% Relative Humidity, non-condensing
Storage Temperature Range	-20 to +80° C

³ Includes non-linearity, hysteresis, and non-repeatability.

Index

Accuracy.....	35	Piping.....	23
applications.....	26	Port	
bidirectional.....	35	Connections.....	23
Cables.....	17	Fitting.....	35
CE compliance.....	39	Pressure	
Circuitry.....	26	Line.....	23
configurable part number.....	34	Proof.....	23
Connectors.....	36	Pressure output.....	17, 35
Contamination.....	23	Ranges.....	34, 38
Customer support.....	18	Relay.....	26
Dimensions.....	25, 38	Returning the product.....	18, 20
Dual supply.....	36	Returns.....	31
ferrule fittings.....	23	Sediment.....	23, 31
Fittings.....	23, 35, 38	Sensor.....	26
Full scale range.....	17	Signal conditioner.....	26
Grounding.....	21	Single supply.....	36
Humidity, Storage.....	24, 39	Span.....	26
Input power.....	21	Supply Current.....	21
Installation Requirements.....	21	Temperature	
Interface cables.....	17	Ambient.....	26
line pressure.....	18	Operating.....	17, 39
Maintenance.....	30	Storage.....	24, 39
Manual organization.....	18	Terminal block adapter.....	36
Materials.....	38	Trip Points.....	26
Mounting.....	22	Troubleshooting.....	31
Operating temperature.....	17	unidirectional.....	36
Orientation.....	22, 24	Vibration.....	22
Output signal.....	17, 35	warm up.....	23, 28
Overpressure.....	24	Zero.....	24, 26, 28, 30
Pin Assignments.....	21		