



HPS™ Products

HPS™ Products Series 423 I-MAG®

Cold Cathode Ionization
Vacuum Sensor

***OPERATION AND
MAINTENANCE MANUAL***

Please Note:

MKS Instruments provides these documents as the latest version for the revision indicated. The material is subject to change without notice, and should be verified if used in a critical application.





HPS™ Products

HPS™ Products Series 423 I-MAG®

Cold Cathode Ionization
Vacuum Sensor

September 1997
PART #104230020 REV. B

Cold Cathode Ionization Vacuum Sensor

Part # 10423000X

Serial # _ _ _ _ _

Please fill in these numbers and have them readily available when calling for service or additional information.

(The part number can be found on your packing slip, and both the part number and serial number are located on the bottom side of the housing.)

For more information or literature, contact:

MKS Instruments, Inc., HPS™ Products Inc.
5330 Sterling Drive
Boulder, CO 80301 USA

Phone: 303-449-9861
800-345-1967

FAX: 303-442-6880

© 1999 by MKS Instruments, Inc., HPS™ Products Inc., All rights reserved.

ALCONOX is a registered trademark of Alconox, Inc.
IgniTorr is a trademark of MKS Instruments, Inc., HPS™ Products Inc.
Inconel is a registered trademark of Inco Alloys International, Inc.
Scotch-Brite is a trademark of 3M.
SensaVac is a registered trademark of MKS Instruments, Inc.

Table of Contents

Table of Contents	
Package Contents	1
Safety Information	2
Symbols	2
Symbols Used in this Manual (English)	2
Symboles utilisés dans ce manuel (Français)	3
In dieser Betriebsanleitung vorkommende Symbole (Deutsch)	4
Símbolos Usados en el Manual (Español)	5
Safety Precautions	6
English	6
Français	6
Español	6
Deutsch	6
Specifications	7
Feature Locations	8
About the HPS™ Series423 I-MAG® Sensor	9
Installing and Using the Series 423 I-MAG® Sensor	10
Locating and Orienting the Sensor	10
Connecting the Sensor	10
Starting the Sensor	10
Operating the Sensor	11
Preparing for Bakeout	11
Maintaining the Series 423 IMAG® Sensor	12
Contamination of the Sensor	12
Disassembly	12
Cleaning	13
Assembly	13
Accessories / Spare Parts	16
Product Warranty	17
NOTES	18



Package Contents

Before unpacking your Series 423 I-MAG[®] Cold Cathode Ionization Vacuum Sensor, check all surfaces of the packing material for shipping damage.

Please be sure that your Series 423 I-MAG[®] Sensor package contains these items:

- ◆ 1 I-MAG[®] Sensor
- ◆ 1 *HPS[™] Series 423 I-MAG[®] Cold Cathode Ionization Vacuum Sensor User's Guide.*
-  If any items are missing from the package, call HPS[™] Customer Service at 1-303-449-9861 or 1-800-345-1967.

Cables are required for connecting the I-MAG[®] Sensor to its controller but are sold separately. Please refer to page 14 for necessary ordering information.

Inspect the I-MAG[®] Sensor for visible evidence of damage during shipment. If it has been damaged, notify the carrier immediately. Keep all shipping materials and packaging for claim verification. Do **not** return the product to HPS[™].

Safety Information

Symbols

Symbols Used in this Manual (English)

Definitions of CAUTION and NOTE messages used throughout the manual.



CAUTION: Risk of electrical shock. ISO 3864, No. B.3.6



CAUTION: Refer to accompanying documents. ISO 3864, No. B.3.1
This sign denotes a hazard. It calls attention to a procedure, practice, condition, or the like, which, if not correctly performed or adhered to, could result in injury to personnel.



This sign denotes a hazard. It calls attention to an operating procedure, practice, or the like, which, if not correctly performed or adhered to, could result in damage to or destruction of all or part of the product.



This sign denotes important information. It calls attention to a procedure, practice, condition, or the like, which is essential to highlight.

Symboles utilisés dans ce manuel (Français)

Définition des indications ATTENTION et REMARQUE utilisées dans ce manuel.



ATTENTION: Risque de secousse électrique. ISO 3864, No. B.3.6



ATTENTION: Se reporter à la documentation. ISO 3864, No. B.3.1
L'indication signale un danger potentiel. Elle est destinée à attirer l'attention sur une procédure, une utilisation, une situation ou toute autre chose présentant un risque de blessure en cas d'exécution incorrecte ou de non-respect des consignes.



L'indication signale un danger potentiel. Elle est destinée à attirer l'attention sur une procédure, une utilisation, une situation ou toute autre chose présentant un risque d'endommagement ou de dégât d'une partie ou de la totalité de l'appareil en cas d'exécution incorrecte ou de non-respect des consignes.



L'indication REMARQUE signale des informations importantes. Elle est destinée à attirer l'attention sur une procédure, une utilisation, une situation ou toute autre chose présentant un intérêt particulier.

In dieser Betriebsanleitung vorkommende Symbole (Deutsch)

Definition der mit VORSICHT! und HINWEIS überschriebenen Abschnitte in dieser Betriebsanleitung.



VORSICHT! Stromschlaggefahr!
ISO 3864, Nr. B.3.6



VORSICHT! Bitte Begleitdokumente lesen! ISO 3864, Nr. B.3.1
Das Symbol VORSICHT! weist auf eine Gefahrenquelle hin. Es macht auf einen Arbeitsablauf, eine Arbeitsweise, einen Zustand oder eine sonstige Gegebenheit aufmerksam, deren unsachgemäße Ausführung bzw. Ungenügende Berücksichtigung zu Körperverletzung führen kann.



Das Symbol VORSICHT! weist auf eine Gefahrenquelle hin. Es macht auf einen Bedienungsablauf, eine Arbeitsweise oder eine sonstige Gegebenheit aufmerksam, deren unsachgemäße Ausführung bzw. Ungenügende Berücksichtigung zu einer Beschädigung oder Zerstörung des Produkts oder von Teilen des Produkts führen kann.



Das Symbol HINWEIS weist auf eine wichtige Mitteilung hin, die auf einen Arbeitsablauf, eine Arbeitsweise, einen Zustand oder eine sonstige Gegebenheit von besonderer Wichtigkeit aufmerksam macht.

Símbolos Usados en el Manual (Español)

Definiciones de los mensajes de PRECAUCIÓN y OBSERVACIÓN usados en el manual.



PRECAUCIÓN: Riesgo de descarga eléctrica. ISO 3864, N.º B.3.6



PRECAUCIÓN: Consultar los documentos adjuntos. ISO 3864, N.º B.3.1 Este símbolo indica un riesgo. Pone de relieve un procedimiento, práctica, condición, etc., que, de no realizarse u observarse correctamente, podría causar lesiones a los empleados.



Esto símbolo indica un riesgo. Pone de relieve un procedimiento, práctica, etc., de tipo operativo que, de no realizarse u observarse correctamente, podría causar desperfectos al instrumento, o llegar incluso a causar su destrucción total o parcial.



Esto símbolo indica información de importancia. Pone de relieve un procedimiento, práctica, condición, etc., cuyo conocimiento resulta esencial.

Safety Precautions

English



High voltages are present in the Sensor during operation.

High voltage is present in the cable and the Sensor when a controller is turned on.

Français



Danger de haute tension.

Une haute tension est présente dans le câble et dans le capteur lorsque le contrôleur est sous tension.

Deutsch



Hochspannungsgefahr!

Bei eingeschaltetem Steuerteil liegt im Kabel und im Sensor Hochspannung an.

Español



Peligro por alto voltaje.

Cuando el controlador está encendido, se registra alto voltaje en el cable y en el sensor.

Specifications

Measuring Range	3.0 x 10 ⁻¹¹ to 1.0 x 10 ⁻² Torr 4.0 x 10 ⁻¹¹ to 1.3 x 10 ⁻² mbar 4.0 x 10 ⁻⁹ to 1.3 x 10 ⁰ Pa 3.0 x 10 ⁻⁸ to 1.0 x 10 ¹ microns
Repeatability	Approximately ±5%
Operating Temperature Range	0° to 70°C (32° to 158°F)
Maximum Bakeout Temperature	500°C (932°F) for CF flanged unit, without cable and magnet
Installation Orientation	Any, vacuum port face down suggested
Internal Volume	0.9 in. ³ (15.0 cm ³) maximum
Materials Exposed to Vacuum	SS 304, SS 302, aluminum, glass, Inconel® X-750, alumina ceramic
External Materials	ABS plastic, stainless steel, aluminum, Ceramic 5 (magnets)
Diameter	2.6 in. (66 mm)
Height (with CF Flange)	3.4 in. (86 mm)
Typical Weight (with CF Flange)	1.8 lb (0.8 kg)
Vacuum Connection	KF 25, KF 40, 2¾" CF (rotatable), 1" tubing
Controller Compatibility	HPS™ Series 421, 929, 937, 941, 953, and MKS Type 146

Design and/or specifications subject to change without notice.

Feature Locations

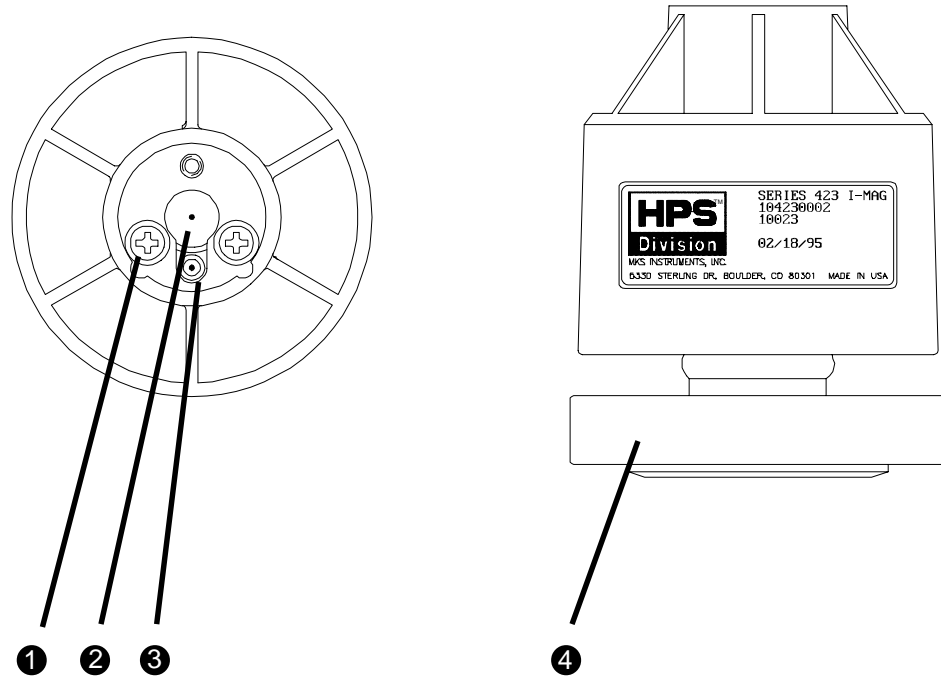

- ① 6-32 x 0.25" Flat Head Countersunk Screw (2)
(For Removal of Magnet for Bakeout)
- ② High Voltage Feed through Pin
- ③ Ion Current Feed through Pin
- ④ Sensor Tube Vacuum Port

About the HPS™ Series 423 I-MAG® Sensor

THE SERIES 423 I-MAG® COLD CATHODE IONIZATION SENSOR is a smaller, less expensive version of our Series 421 Sensor. The I-MAG® Sensor uses the same isolated collector design previously unique to the Series 421 Sensor. Experimentally, the isolated collector has proven to provide continuous pressure measurement to 10^{-11} Torr.

With an output equivalent to the Series 421 Sensor, the I-MAG® Sensor, together with its cable, is fully compatible with all HPS™ cold cathode sensor controllers, as well as the MKS Type 146 vacuum sensor measurement and control system.

Additional features include a removable magnet, replaceable internal components, no elastomers or any other high outgassing materials in vacuum, compact size, low mass, low internal volume, and excellent resistance to thermal shock.

Cables for the I-MAG® Sensor include circuitry to protect the user from shock and to protect the controller's sensitive electrometer against excessive voltage.



Installing and Using the Series 423 I-MAG[®] Sensor

Locating and Orienting the Sensor

Locate the I-MAG[®] Sensor where it can measure process chamber or manifold pressure. Install it away from pumps, other vibration sources, and gas sources to give the most representative values. The magnetic field of the Sensor should also be kept away from ion or electron beam sources.

Locate and orient the I-MAG[®] Sensor where contamination is least likely. If it is installed directly above a diffusion pump, for example, oil vapor could contaminate the cathode, anode, or other vacuum exposed components, causing the calibration to shift.

The I-MAG[®] Sensor can be installed with the body set in any direction. Operating position does not affect accuracy. Installing it with the vacuum port facing down is optimal as this helps prevent contaminants falling into it.



Operation at pressures above 10^{-3} Torr for extended periods will increase the likelihood of contamination.

Connecting the Sensor

Mount the Sensor to a grounded vacuum system.

If the I-MAG[®] Sensor has a CF flange, remove the magnet first to allow clearance for bolt installation. When replacing the magnet, note that it is keyed to the sensor body to protect the feed through pins from damage. The pins should be straight and centered.

Use an all-metal clamp to mount a KF 25 or KF 40 flanged sensor body.

Connect the cable to the Sensor and to your controller before turning on your system. Tighten the thumb screw on top of the cable to make sure it is securely in place and for strain relief.

Starting the Sensor

The I-MAG[®] Sensor starts quickly in the rough to medium vacuum ranges. In the UHV pressure range, starting may be delayed by several minutes. Use a HPS[™] IgniTorr[™] Cold Cathode Starting Device to help significantly reduce starting time (see **Accessories**, p. 16).

Operating the Sensor



Operation at pressures above 10^{-3} Torr for extended periods will increase the likelihood of contamination.

High voltage should be disabled at pressures above 10^{-2} Torr to prevent sputtering.

Preparing for Bakeout

Loosen the thumb screw on top of the cable and remove it. Loosen the two flathead screws located on top of the Sensor, and then remove the magnet. The remainder of the Sensor is ready to be baked out to 500°C if using a CF flange or to 150°C if using a KF flange.

Maintaining the Series 423 IMAG[®] Sensor



For this chapter, please refer to the figure shown on page 15.

Contamination of the Sensor

If pressure readings appear to be erratic, the Sensor tube may be contaminated. Inspect it visually. If contamination is visible, you should replace the internal components with an Internal Rebuild Kit (see **Accessories**, p. 16).

Depending on the degree of contamination and application of the Sensor, the internal parts may be cleaned — either ultrasonically, with mild abrasives, or chemically.

Disassembly

Tools required: clean tweezers; clean, smooth-jaw, needle-nose pliers

- 1 Loosen the thumb screw on top of the sensor cable and then remove it. Loosen the two *flat head screws* 15. Remove the *magnet* 14.
- 2 Using the smooth-jaw, needle-nose pliers, firmly grab the *compression spring* 1 at the tip closest to the flange.
- 3 Pull on the compression spring while rotating it to free it from the formed groove of the *sensor body* 7. Continue to pull until the *compression spring* is completely free.
- 4 Carefully remove the remaining components from the *sensor body*.



Do not bend the anode 8 or the leaf spring 9 on the ion current feed through pin 13 when assembling or disassembling the Sensor as they are very fragile and could break.

Cleaning

If **ultrasonic cleaning**, use high quality detergents compatible with aluminum, such as ALCONOX®.

Scrubbing with mild abrasives can remove most contamination. Scotch-Brite™ or a fine emery cloth may be effective. Rinse with alcohol.

Clean aluminum and ceramic parts chemically in a wash, such as a 5 to 20% sodium hydroxide solution (not for semiconductor processing), at room temperature (20°C) for one minute. Follow with a preliminary rinse of deionized water. Remove smut (the black residue left on aluminum parts due to this process) in a 50 to 70% nitric acid dip for about 5 minutes.



Chemical cleaning should not be used to clean the anode; mild abrasives or ultrasonic cleaning are acceptable.



Do not damage the leaf spring while cleaning the Sensor.

Each of the above cleaning methods should be followed with multiple rinses of deionized water.

Dry all internal components and the *sensor body* ⑦ in a clean oven. The two *ceramic spacers*, ② and ⑤, are slightly porous and will require longer drying time in the oven to drive off the absorbed water.

Assembly



Wear gloves and assemble with clean tools.

- 1 Check the *anode* ⑧. It should be straight and centered with the *sensor body* ⑦ for proper operation.
- 2 Roll the *sensor body* on a flat surface and look for any radial run out motion.
- 3 Install the *ground shield* ⑥ using tweezers. Make sure that at the groove of its larger diameter, the *ground shield* interlocks with the *locating collar* ⑪.
- 4 Slide the *small ceramic spacer* ⑤ over the small end of the *ground shield* ⑥. Check that the *leaf spring* ⑨ will contact the base of the *cathode* ④ as shown to the right. If not, remove the *small ceramic spacer* and the *ground shield*. Gently bend the *leaf spring* towards the *anode* ⑧, and then replace the *ground shield* and *ceramic spacer*.

- 5 Slide the *cathode* ④, the *grid washer* ③ and the *large ceramic spacer* ② into place. The *grid washer* has a concave shape. Refer to the figure to see its installation orientation.
- 6 Insert the small end of the *compression spring* ① into the *sensor body* ⑦. Using your thumbs, push the larger end of the spring into the *sensor body* until it is contained within the tube's inside diameter. Using the smooth-jaw, needle-nose pliers, work the *compression spring* down into the sensor body until it is fully seated in the formed groove.
- 7 Inspect the *ground shield* ⑥ and the *grid washer* ③ to verify they are centered with respect to the *anode* ③. If adjustment is needed, gently reposition the grid washer/cathode assembly, taking care not to scratch the *grid washer*.

 **We suggest you measure the resistance between the ion current feed through pin ⑬ and the grid washer ③ to verify that the leaf spring ⑨ is in contact with the cathode ④. The measurement should indicate a short circuit between them. There should be an open circuit between the ion current feed through pin ⑬ and both the high voltage feed through pin ⑩ and sensor body ⑦.**

The I-MAG[®] Sensor is ready for installation. If it is not immediately installed, cover the flange with clean, vacuum grade aluminum foil and cap it with a flange protector.

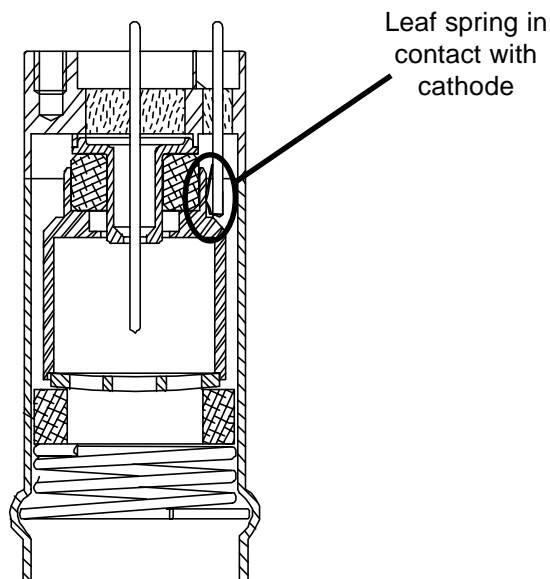

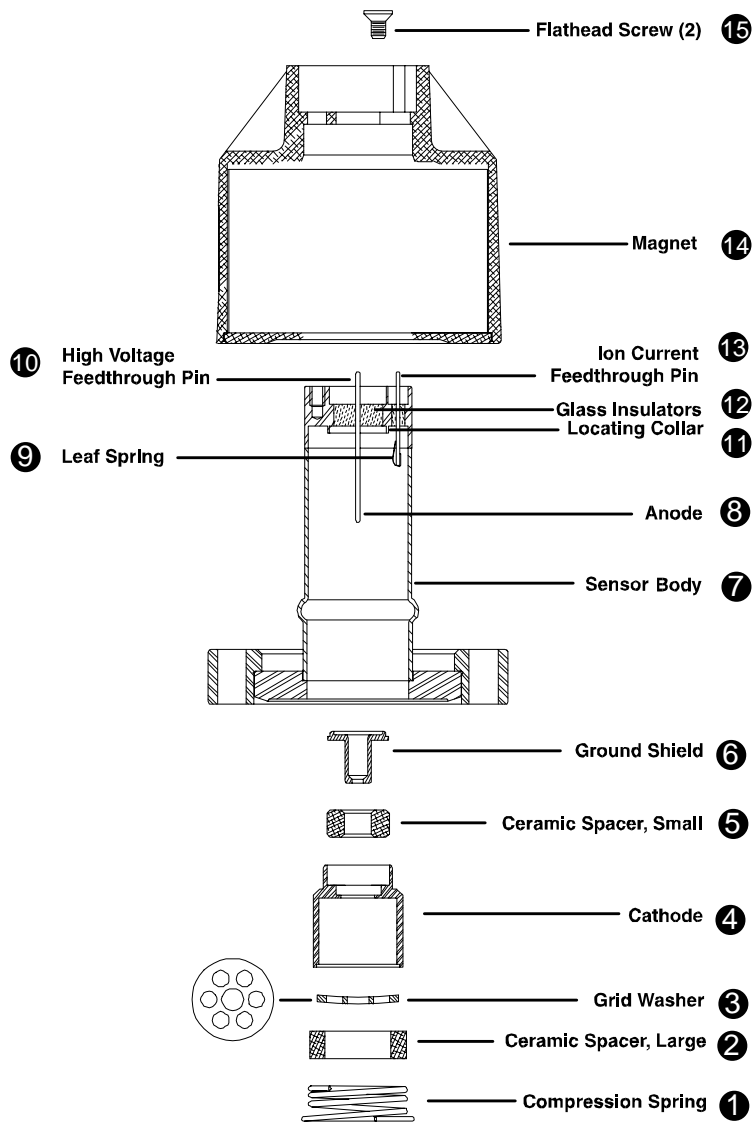

Accessories / Spare Parts

Part #

IgniTorr™ Cold Cathode Starting Device

120V	100006850
220V	100007090

I-MAG® Cold Cathode Cable

2 ft	100002505
10 ft	100007873
25 ft	100007874
50 ft	100002395
Custom, to 500 ft	100008759

Internal Rebuild Kit 100002353

Cathode, Grid Washer, Ground Shield,
Ceramic Spacers – 1 Sm and 1 Lrg, Spring

Please call HPS™ Customer Service Department at 1-303-449-9861 or 1-800-345-1967 to order any of these parts or to receive catalogs for other HPS™ products.

Product Warranty

Extent of the Warranty

MKS Instruments, Inc., warrants HPS™ Products Series 423 I-MAG® Sensor and its accessories to be free from defects in materials and workmanship for one (1) year from the date of shipment by HPS™ or authorized representative to the original purchaser (PURCHASER). Any product or parts of the product repaired or replaced by HPS™ under this warranty are warranted only for the remaining unexpired part of its one (1) year original warranty period. After expiration of the applicable warranty period, the PURCHASER shall be charged HPS™' current prices for parts and labor, plus any transportation for any repairs or replacement.

ALL EXPRESS AND IMPLIED WARRANTIES, INCLUDING THE IMPLIED WARRANTIES OF MERCHANTABILITY AND FITNESS FOR A PARTICULAR PURPOSE, ARE LIMITED TO THE WARRANTY PERIOD. NO WARRANTIES, EXPRESS OR IMPLIED, WILL APPLY AFTER THIS PERIOD.

Warranty Service

The obligations of HPS™ under this warranty shall be at its option: (1) to repair, replace, or adjust the product so that it meets applicable product specifications published by HPS™ or (2) to refund the purchase price.

What Is Not Covered

The product is subject to above terms only if located in the country of the seller from whom the product was purchased. The above warranties do not apply to:

- I. Damages or malfunctions due to failure to provide reasonable and necessary maintenance in accordance with HPS™ operating instructions.
- II. Damages or malfunctions due to chemical or electrolytic influences or use of the product in working environments outside the specification.
- III. Fuses and all expendable items which by their nature or limited lifetime may not function for a year. If such items fail to give reasonable service for a reasonable period of time within the warranty period of the product; they will, at the option of HPS™, be repaired or replaced.
- IV. Defects or damages caused by modifications and repairs effected by the original PURCHASER or third parties not authorized in the manual.

Condition of Returned Products

HPS™ will not accept for repair, replacement, or credit any product which is asserted to be defective by the PURCHASER, or any product for which paid or unpaid service is desired, if the product is contaminated with potentially corrosive, reactive, harmful, or radioactive materials, gases, or chemicals.

When products are used with toxic chemicals, or in an atmosphere that is dangerous to the health of humans, or is environmentally unsafe, it is the responsibility of the PURCHASER to have the product cleaned by an independent agency skilled and approved in the handling and cleaning of contaminated materials before the product will be accepted by HPS™ for repair and/or replacement.

In the course of implementing this policy, HPS™ Customer Service Personnel may inquire of the PURCHASER whether the product has been contaminated with or exposed to potentially corrosive, reactive, harmful, or radioactive materials, gases, or chemicals when the PURCHASER requests a return authorization. Notwithstanding such inquiries, it is the responsibility of the PURCHASER to ensure that no products are returned to HPS™ which have been contaminated in the aforementioned manner.

Other Rights and Remedies

I. These remedies are exclusive. HPS SHALL NOT BE LIABLE FOR CONSEQUENTIAL DAMAGES, FOR ANTICIPATED OR LOST PROFITS, INCIDENTAL DAMAGES OR LOSS OF TIME, OR OTHER LOSSES INCURRED BY THE PURCHASER OR BY ANY THIRD PARTY IN CONNECTION WITH THE PRODUCT COVERED BY THIS WARRANTY, OR OTHERWISE. Some states do not allow exclusion or limitation of incidental or consequential damage or do not allow the limitation on how long an implied warranty lasts. If such laws apply, the limitations or exclusions expressed herein may not apply to PURCHASER.

II. Unless otherwise explicitly agreed in writing, it is understood that these are the only written warranties given by HPS™. Any statements made by any persons, including representatives of HPS™, which are inconsistent or in conflict with the terms of the warranty shall not be binding on HPS unless reduced to writing and approved by an authorized officer of HPS™.

III. This warranty gives PURCHASER specific legal rights, and PURCHASER may also have other rights which vary from state to state.

IV. For HPS™ products sold outside of the U.S., contact your MKS representative for warranty information and service.

Warranty Performance

To obtain warranty satisfaction, contact the following: MKS Instruments, HPS™ products Inc., 5330 Sterling Drive, Boulder, CO 80301, USA, at phone number (303) 449-9861.



NOTES

