

Series 390

Granville-Phillips® Series 390 Micro-Ion® ATM
Four-Sensor Combination Vacuum Gauge Module
with DeviceNet™ and RS-485 Interface,
and Analog Output

GRANVILLE-PHILLIPS®

Instruction Manual

Instruction manual part number 390002

Revision E - August 2013



Series 390

Granville-Phillips® Series 390 Micro-Ion® ATM Four-Sensor Combination Vacuum Gauge Module with DeviceNet™ and RS-485 Interface, and Analog Output

This Instruction Manual is for use with all Granville-Phillips Series 390 Micro-Ion ATM Modules with DeviceNet and RS-485 Interface, and Analog Output. A list of applicable catalog numbers is provided on the following page.

These products are RoHS compliant.

GRANVILLE-PHILLIPS®

Customer Service/Support

For customer service within USA, 8 AM to 5 PM
Mountain Time Zone, weekdays excluding holidays:

Granville-Phillips

6450 Dry Creek Parkway
Longmont, CO 80503 USA
Phone: +1-800-776-6543
Phone: +1-303-652-4400
FAX: +1-303-652-2844
Email: co-csr@brooks.com

Brooks Automation, Inc.

15 Elizabeth Drive
Chelmsford, MA 01824 USA
Phone: +1-978-262-2400

For customer service, 24 hours per day, 7 days per week,
every day of the year including holidays within the USA:

Phone: +1-800-367-4887

www.brooks.com

Instruction Manual

© 2006-2013 Brooks Automation, Inc. All rights reserved.
Granville-Phillips®, Micro-Ion®, and Conductron® are registered trademarks of
Brooks Automation, Inc. All other trademarks and registered trademarks are the
properties of their respective owners.



Granville-Phillips® Series 390 Micro-Ion® ATM Four-Sensor Combination Vacuum Gauge with DeviceNet™ and RS-485 Interface, and Analog Output

Catalog numbers for Series 390 Micro-Ion ATM Modules

Power supply and cable are not included.

DeviceNet interface - no display: 390610 - # - # # - #

DeviceNet interface - with digital display: 390611 - # - # # - #

Setpoints:

None
Two
Three

0
2
3

Ion Gauge Filaments:

Yttria-coated iridium
Tungsten

Y
T

Flange/Fitting:

NW16KF
NW25KF
NW40KF
1.33 inch (NW16CF) Conflat-type
2.75 inch (NW35CF) Conflat-type
1/2 inch VCR-type male

D
E
K
F
G
H

Measurement Units:

Torr
mbar
Pascal

T
M
P

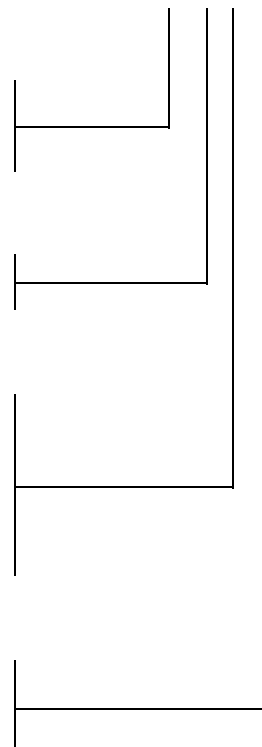

Table of Contents

Chapter 1	Before You Begin	9
	1.1 About these instructions	9
	1.2 Caution and warning statements	9
	1.3 System Grounding	10
	1.4 Implosion / Explosion	10
	1.5 Operation	11
	1.6 Reading and following instructions	11
	1.7 Definitions of terms	12
	1.8 Customer service	14
Chapter 2	Installation	15
	2.1 Module components	15
	2.2 Pressure relief devices	15
	2.3 Installation procedure	16
	Step 1 Locate the module	16
	Step 2 Attach the module to the vacuum chamber	18
	VCR type fitting	18
	KF flange	18
	ConFlat flange	18
	Step 3 Assemble and connect wiring	19
	Connecting cable	19
	CE Mark compliance	20
	Module power supply	20
	Gauge OFF/degas wiring	21
	Relay, analog output, and RS-485 output wiring	21
	DeviceNet wiring	22
	Grounding	22
	Step 4 Calibrate module at atmospheric pressure	24
	2.4 Eliminating radio frequency interference	24
Chapter 3	Operation Overview	25
	3.1 Interfaces, outputs, and relays	25
	3.2 Analog operation	25
	3.3 DeviceNet operation	25
	3.4 RS-485 operation	27
	3.5 Automatic filament selection	28
Chapter 4	Analog Operation	29
	4.1 Output functions	29
	4.2 Preparing to operate the module	29

4.3	Operational tasks	29
4.4	LED status indicator	30
4.5	Reading pressure	31
4.6	Micro-Ion gauge OFF	32
4.7	Micro-Ion gauge degas	33
4.8	Calibration	34
	Atmospheric pressure calibration	35
	Vacuum pressure calibration	35

Chapter 5

	DeviceNet Operation	37
5.1	Pressure output and relay functions	37
5.2	Preparing to operate the module	37
5.3	Performance with DeviceNet protocol	38
5.4	DeviceNet protocol for the Micro-Ion ATM module	39
5.5	Operational tasks	39
5.6	DeviceNet switches and indicators	40
	Address switches	40
	Rate switch	41
5.7	Status LEDs	41
5.8	DeviceNet communication configuration	43
5.9	Pressure units and values	47
	Set or get pressure unit	47
	Data conversion	47
	Get vacuum pressure or differential pressure	48
5.10	Get temperature	51
5.11	Process control relays	51
	Get relay trip points	55
	Get enable/disable status of relays	55
	Get activation or deactivation status of relays	56
	Get relay hysteresis	57
	Get relay assignments	57
5.12	Micro-Ion gauge controls	58
	Turn Micro-Ion gauge ON or OFF	58
	Get Micro-Ion gauge ON/OFF status	59
	Set or get Micro-Ion gauge delay time	59
	Set or get filament mode	60
	Get active filament	61
	Initiate or terminate Micro-Ion gauge degas	62
	Get Micro-Ion gauge degas ON/OFF state	63
	Set or get Micro-Ion gauge emission current	63
5.13	Calibrate module at atmospheric pressure	65
5.14	Calibrate module at vacuum pressure	65
5.15	Reset module to power-up state	66
5.16	Get firmware version	66
5.17	Get software and hardware revision levels	66

5.18	Factory defaults	67
5.19	DeviceNet error codes	68
	Using polled I/O	68
	Using explicit messages	68
Chapter 6	RS-485 Operation	73
6.1	Pressure output and relay functions	73
6.2	Preparing to operate the module	73
6.3	RS-485 physical layer	74
6.4	Operational tasks	75
6.5	Error responses	75
6.6	Data timing and response	76
6.7	RS-485 commands	77
	Command structure	77
	Symbols used in this manual	77
6.8	RS-485 command set	78
	TLU Toggling locked functions	80
	UNL Unlock interface functions	80
	SA Set address offset	81
	SB Set baud rate	82
	yuiop Restore RS-485 communication defaults	82
	SU Set pressure unit	82
	RU Read pressure unit	82
	SD Set pressure indication for optional display	82
	RD Read vacuum pressure	83
	RDD Read differential pressure	83
	PC Process control relay trip points	84
	PCG Set trip point relay assignments	87
	PCE Set or read disable/enable state of relays	87
	RPCS Read trip point relay status	88
	IG Turn Micro-Ion gauge ON or OFF	88
	IGS Read Micro-Ion gauge ON/OFF status	88
	IGM Set or read pressure indication when Micro-Ion gauge is OFF	89
	IOD Set or read Micro-Ion gauge delay ON/OFF state	90
	IDT Set or read Micro-Ion gauge delay time	91
	SF Set Micro-Ion gauge filament mode	92
	RF Read Micro-Ion gauge filament status	96
	DG Degas Micro-Ion gauge	96
	DGS Read Micro-Ion gauge degas status	96
	DGT Set or read Micro-Ion gauge degas time	97
	SER Set emission current switch point	97
	RE Read Micro-Ion gauge emission current	99
	TS Calibrate module at atmospheric pressure	99
	TZ Calibrate module at vacuum pressure	100

	ATM	Set or read atmospheric pressure output	101
	RS	Read module status RS-485 strings	101
	RSX	Read module status hexadecimal bits	103
	RST	Reset module to power-up state	105
	FAC	Reset values to factory defaults	106
	VER	Read firmware version	106
Chapter 7	Optional Display		107
	7.1	Display capabilities	107
		Vacuum pressure display	107
		Differential pressure display	107
	7.2	Display resolution	108
	7.3	Error conditions	108
Chapter 8	Maintenance		111
	8.1	Customer service	111
		Damage requiring service	111
	8.2	Troubleshooting	111
		Precautions	112
		Symptoms, causes, and solutions	112
	8.3	RS-485 error responses	114
	8.4	RS-485 status strings and hexadecimal bits	115
	8.5	DeviceNet error codes	115
		Using polled I/O	115
		Using explicit messages	115
	8.6	Overpressure shutdown	116
	8.7	Micro-Ion gauge continuity test	116
	8.8	Replacing the gauge assembly	118
	8.9	Returning a Micro-Ion module for service	119
Appendix A	Specifications & Compliance		121
Appendix B	Messaging Summary		129
Appendix C	Theory of Operation		143
Index			147

Chapter 1 Before You Begin

1.1 About these instructions

These instructions explain how to install, operate, and maintain the Granville-Phillips® Micro-Ion® ATM vacuum gauge module.

The module has a DeviceNet interface, an RS-485 interface, and one analog output. The module may have no trip point relays, two trip point relays, or three trip point relays.

- *This chapter* explains caution and warning statements, which must be adhered to at all times; explains your responsibility for reading and following all instructions; defines the terms that are used throughout this instruction manual; and explains how to contact customer service.
- *Chapter 2* explains how to install the module.
- *Chapter 3* is an operational overview of the module.
- *Chapter 4* explains analog output operation. The analog output does not operate independently but must operate with the DeviceNet or RS-485 interface.
- *Chapter 5* explains DeviceNet interface operation.
- *Chapter 6* explains RS-485 interface operation.
- *Chapter 7* explains how to use the optional display.
- *Chapter 8* explains troubleshooting; Micro-Ion gauge testing, removal and replacement; and module return procedures.
- *Appendix A* provides specifications for the module.
- *Appendix B* summarizes DeviceNet polled I/O and explicit messages.
- *Appendix C* explains how the Micro-Ion gauge, Conductron® heat-loss sensor, atmospheric pressure diaphragm sensor, and vacuum pressure diaphragm sensor measure pressure.

1.2 Caution and warning statements

This manual contains caution and warning statements with which you *must* comply with to prevent inaccurate measurement, property damage, or personal injury.



CAUTION

Caution statements alert you to hazards or unsafe practices that could result in inaccurate measurement, minor personal injury or property damage.

Each caution statement explains what you must do to prevent or avoid the potential result of the specified hazard or unsafe practice.

 **WARNING**

Warning statements alert you to hazards or unsafe practices that could result in severe property damage or personal injury due to electrical shock, fire, or explosion.

Each warning statement explains what you must do to prevent or avoid the potential result of the specified hazard or unsafe practice.

Caution and warning statements comply with American Institute of Standards Z535.1-2002 through Z535.5-2002, which set forth voluntary practices regarding the content and appearance of safety signs, symbols, and labels.

Each caution or warning statement explains:

- a. The specific hazard that you *must* prevent or unsafe practice that you *must* avoid,
- b. The potential result of your failure to prevent the specified hazard or avoid the unsafe practice, and
- c. What you *must* do to prevent the specified hazardous result.

1.3 System Grounding

Grounding, though simple, is very important! Be certain that ground circuits are correctly used on your ion gauge power supplies, gauges, and vacuum chambers, regardless of their manufacturer. Safe operation of vacuum equipment, including the Series 390 ATM Module, requires grounding of all exposed conductors of the gauges, the controller and the vacuum system. **LETHAL VOLTAGES** may be established under some operating conditions unless correct grounding is provided.

Ion producing equipment, such as ionization gauges, mass spectrometers, sputtering systems, etc., from many manufacturers may, under some conditions, provide sufficient electrical conduction via a plasma to couple a high voltage electrode potential to the vacuum chamber. If exposed conductive parts of the gauge, controller, and chamber are not properly grounded, they may attain a potential near that of the high voltage electrode during this coupling. Potential fatal electrical shock could then occur because of the high voltage between these exposed conductors and ground.

1.4 Implosion / Explosion

Danger of injury to personnel and damage to equipment exists on all vacuum systems that incorporate gas sources or involve processes capable of pressuring the system above the limits it can safely withstand.

For example, danger of explosion in a vacuum system exists during backfilling from pressurized gas cylinders because many vacuum devices such as ionization gauge tubes, glass windows, glass belljars, etc., are not designed to be pressurized.

Install suitable devices that will limit the pressure from external gas sources to the level that the vacuum system can safely withstand. In addition, install suitable pressure relief valves or rupture disks that will release pressure at a level considerably below that pressure which the system can safely withstand.

Suppliers of pressure relief valves and pressure relief disks are listed in Thomas Register under "Valves, Relief", and "Discs, Rupture".

Confirm that these safety devices are properly installed before installing the Series 390 ATM Module. In addition, check that (1) the proper gas cylinders are installed, (2) gas cylinder valve positions are correct on manual systems, and (3) the automation is correct on automated systems.

1.5 Operation

It is the installer's responsibility to ensure that the automatic signals provided by the process control module are always used in a safe manner.

Carefully check manual operation of the system and the setpoint programming before switching to automatic operation. Where an equipment malfunction could cause a hazardous situation, always provide for fail-safe operation. As an example, in an automatic backfill operation where a malfunction might cause high internal pressures, provide an appropriate pressure relief device.

1.6 Reading and following instructions

You must comply with all instructions while you are installing, operating, or maintaining the module. Failure to comply with the instructions violates standards of design, manufacture, and intended use of the module. Granville-Phillips and Brooks Automation disclaim all liability for the customer's failure to comply with the instructions.

- *Read instructions* – Read all instructions before installing or operating the product.
- *Follow instructions* – Follow all installation, operating and maintenance instructions.
- *Retain instructions* – Retain the instructions for future reference.
- *Heed warnings and cautions* – Adhere to all warnings and caution statements on the product and in these instructions.
- *Parts and accessories* – Install only those replacement parts and accessories that are recommended by Granville-Phillips. Substitution of parts is hazardous.

1.7 Definitions of terms

Table 1-1 lists terms used throughout this manual in reference to the Micro-Ion ATM vacuum gauge module.

Table 1-2 lists terms describing DeviceNet protocol.

Table 1-3 lists terms describing DeviceNet data types.

Table 1-1 Terms describing Micro-Ion ATM module and components

Term	Description
Module	The entire Micro-Ion ATM product, which includes the housing, gauge assembly, and electronics assembly.
Gauge assembly	A removable assembly that contains a hot filament Micro-Ion gauge (Bayard-Alpert type ionization gauge), a Conductron heat-loss sensor, a vacuum pressure diaphragm sensor, and the vacuum chamber connection.
Electronics assembly	An assembly that contains the electronic circuitry, signal processing microcircuitry, and atmospheric pressure diaphragm sensor.
Micro-Ion [®] gauge	The Bayard-Alpert type ionization gauge, which indicates pressure by producing a current that is proportional to gas density.
Conductron [®] sensor	The heat-loss sensor, which measures pressure as a function of heat loss from the gold-plated tungsten sensing wire.
Vacuum pressure diaphragm sensor	A Piezo resistive diaphragm sensor that measures vacuum pressure. Vacuum pressure is compared to atmospheric pressure to determine the differential between atmospheric and vacuum pressures.
Atmospheric pressure diaphragm sensor	A Piezo resistive diaphragm sensor that measures atmospheric pressure. Atmospheric pressure is compared to vacuum pressure to determine the differential between atmospheric and vacuum pressures.
Vacuum pressure	The pressure of the process gas inside the vacuum chamber, measured by the Micro-Ion gauge, Conductron sensor, and vacuum pressure diaphragm sensor.
Atmospheric pressure	The ambient air pressure of the atmosphere outside the module, measured by the atmospheric pressure diaphragm sensor.
Differential pressure	The difference between atmospheric pressure and vacuum pressure. Differential pressure zero is the pressure value at which vacuum pressure equals atmospheric pressure.

Table 1-2 Terms describing DeviceNet protocol

Term	Description
Class	Referred to in DeviceNet language as an “object”. The DeviceNet protocol is divided into various objects that describe behaviors, attributes, or information. For example, class 1 is the identity object that includes information about the identity of the product, such as the vendor identification, product type, product ID, serial number, and firmware revisions.
Instance	Within a class there may be multiple instances. Within the Micro-Ion ATM module there are four possible I/O instances (1–4). For example, the format for polled I/O data is instance 2 in class 5.
Attribute	Data that can be read from the device or written to the DeviceNet network. Attributes exist for each instance within a class. For example, the serial number is attribute 6, instance 1 in class 1 (the identity object).
Master data	The messages sent from the network to the device to set conditions or values in the device.
Device data	The messages sent from the Micro-Ion ATM module to the network to communicate values, attributes, or other information.
Data rate	The rate at which data is transmitted (125, 250, or 500 kbaud, switch selectable).
Explicit messages	Messages that are used for request/response communications enabling module configuration and problem diagnosis. Explicit messages provide multi-purpose, point-to-point communication paths between two modules or other devices.
Polled I/O messages	Messages that are used for time-critical, control-oriented data. Polled I/O messages provide a dedicated, special-purpose communication path between a producing application (host) and one or more consuming applications (modules or other devices).
Address	The address of a device on the DeviceNet network.

Table 1-3 Terms describing DeviceNet data types

Term	Description
Data type	The form of the data communicated from the Micro-Ion ATM module or another node on the network. The module supports BOOL, BYTE, SSTRING, REAL, INT, UINT, USINT, EPATH, and WORD data types.
BOOL data	A single ON/OFF bit, where 1 = ON (true), 0 = OFF (false).
BYTE data	An 8-bit string, from most significant to least significant bit.
STRUCT data	A string of bits, each of which can be set to ON (true) = 1 or OFF (false) = 0.
SSTRING data	A character string, one byte per character, with one byte length indicator.
REAL data	A 32-bit floating point value in single precision IEEE 754 format.
INT data	A 2-byte (16-bit) integer value from -32767 to +32767.
UINT data	A 16-bit unsigned integer value from 0 to 65535.
USINT data	An 8-bit unsigned integer value from 0 to 255.
EPATH	DeviceNet path segments requiring abstract syntax encoding.
WORD data	A 16-bit string.

1.8 Customer service

For customer service:

- Phone 1-303-652-4400 or 1-800-776-6543, 8 AM to 5 PM Mountain Time Zone weekdays, excluding holidays within the USA.
- Phone 1-800-367-GUTS (1-800-367-4887) 24 hours per day, seven days per week within the USA.
- Email co-csr@brooks.com
- For Global Customer Support, go to www.brooks.com and click on *Services* to locate the Brooks Automation office nearest you.

Chapter 2 Installation

2.1 Module components

The Micro-Ion ATM module contains a Micro-Ion gauge (Bayard-Alpert type ionization gauge), a Conductron heat-loss sensor, an atmospheric pressure diaphragm sensor, and a vacuum pressure diaphragm sensor.

WARNING

Using the module to measure the pressure of flammable or explosive gases can cause a fire or explosion resulting in severe property damage or personal injury.

Do not use the module to measure the pressure of flammable or explosive gases.

WARNING

Exposing the module to moisture can cause fire or electrical shock resulting in severe property damage or personal injury.

To avoid exposing the module to moisture, install the module in an indoor environment. Do not install the module in any outdoor environment.

2.2 Pressure relief devices

Before you install the module, you should install appropriate pressure relief devices in the vacuum system.

Brooks Automation does not supply pressure relief valves or rupture disks. Suppliers of pressure relief valves and rupture disks are listed in the *Thomas Register* under “Valves, Relief” and “Discs, Rupture.”

CAUTION

Operating the module above 1000 Torr (1333 mbar, 133 kPa) true pressure could cause pressure measurement error or product failure.

To avoid measurement error or product failure due to overpressurization, install pressure relief valves or rupture disks in the system if pressure substantially exceeds 1000 Torr (1333 mbar, 133 kPa).

2.3 Installation procedure

The module installation procedure includes the following steps:

1. Determine the location of the module on the vacuum chamber.
2. Attach the module's flange / fitting to its mating fitting on the vacuum chamber.
3. Assemble and connect the module wiring.
4. Calibrate the module at atmospheric pressure.

This chapter also explains what to do if radio frequency interference (RFI) disrupts operation of RS-485 version of the module.

Step 1 *Locate the module*

To locate the module, refer to Figure 2-1 and follow the guidelines below.

- For greatest accuracy and repeatability, locate the module in a stable, room-temperature environment. Ambient temperature should never exceed 40 °C (104 °F) operating, non-condensing, or 85 °C (185 °F) non-operating. Bakeout temperature with the electronics removed from the module is 105 °C (221 °F).
- Locate the module away from internal and external heat sources and in an area where ambient temperature remains reasonably constant.
- Do not locate the module near the pump, where gauge pressure might be lower than system vacuum pressure.
- Do not locate the module near a gas inlet or other source of contamination, where inflow of gas or particulates causes atmospheric pressure to be higher than system atmosphere.
- Do not locate the module where it will be exposed to corrosive gases such as mercury vapor or fluorine.

Figure 2-1 Dimensions

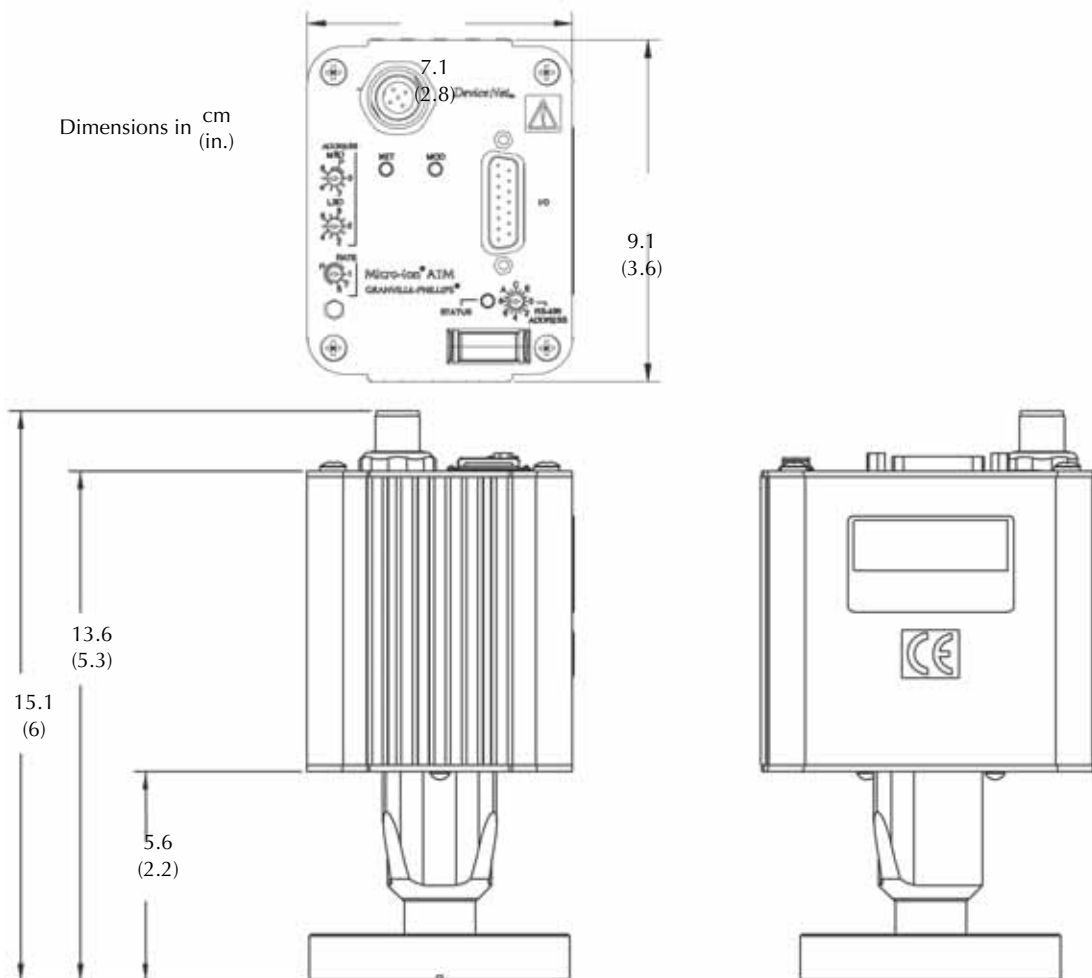

Installation

Step 2 *Attach the module to the vacuum chamber*

Attach the module's flange/fitting to its mating fitting on the vacuum chamber.

	CAUTION
<p>Twisting the module to tighten the fitting to the vacuum chamber can damage the module's internal connections.</p> <ul style="list-style-type: none"> • Do not twist the module to tighten the fitting. • Use appropriate tools to tighten the fitting. 	

VCR type fitting



VCR type fitting:

- a. Remove the bead protector cap from the fitting.
- b. Place the gasket into the female nut.
- c. Assemble the components and tighten them to finger-tight.
- d. While holding a back-up wrench stationary, tighten the female nut 1/8 turn past finger-tight on 316 stainless steel or nickel gaskets, or 1/4 turn past finger-tight on copper or aluminum gaskets. *Do not twist the module to tighten the fitting.*

KF flange



The KF mounting system requires O-rings and centering rings between mating flanges.

- a. Tighten the clamp to compress the mating flanges together.
- b. Seal the O-ring.

ConFlat flange



To minimize the possibility of leaks with ConFlat® flanges, use high strength stainless steel bolts and a new, clean OFHC copper gasket. Avoid scratching the seal surfaces. To avoid contamination, install new metal gaskets.

- a. Finger tighten all bolts.
- b. Use a wrench to continue tightening 1/8 turn at a time in crisscross order (1, 4, 2, 5, 3, 6) until flange faces make contact.
- c. Further tighten each bolt about 1/16 turn.

Step 3 Assemble and connect wiring**Connecting cable**

Cable is user-supplied. Brooks Automation does not supply cable. Install externally shielded cable.

Wiring connects to the 15-pin I/O wiring connector or the DeviceNet 5-pin micro connector. See Figure 2-2.

- Connect module power-supply wiring, analog output wiring, RS-485 output wiring, and relay wiring to the 15-pin connector.
- To turn the Micro-Ion gauge ON or OFF, install a switch between terminals 3 and 5 on the 15-pin connector.
- To degas the Micro-Ion gauge, install a switch between terminals 7 and 8 on the 15-pin connector.
- Connect DeviceNet power-supply and network wiring to the DeviceNet 5-pin micro connector.

Figure 2-2 15-pin I/O connector and DeviceNet 5-pin micro connector

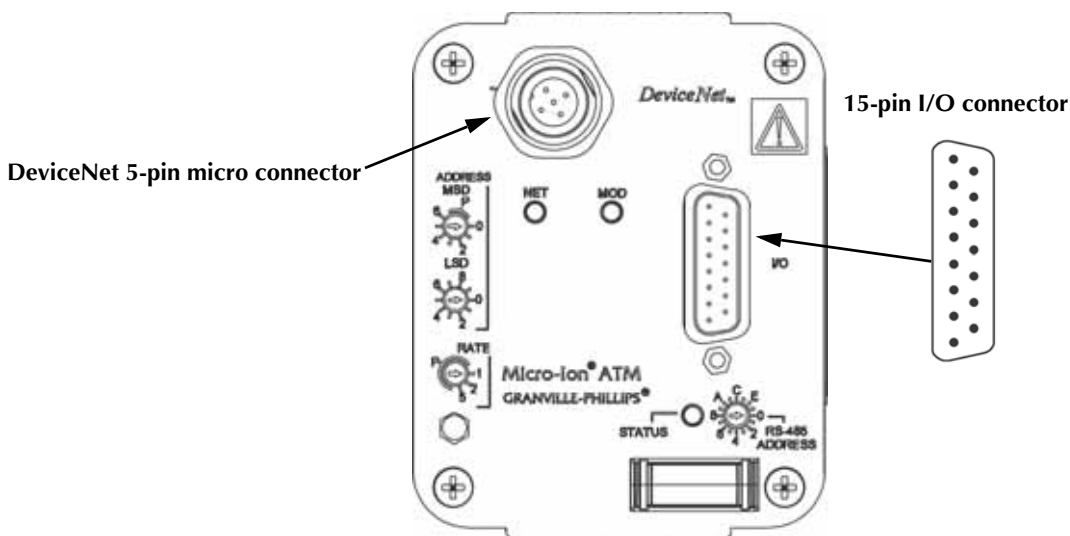

CE Mark compliance

For CE mark compliance, use the following cable types (or equivalent):

Cable to 15-pin I/O connector

For the cable that connects to the 15-pin I/O connector, install shielded cable with aluminum jacket and a tinned copper braid with a minimum of 65% coverage.

On the module end of the cable, install a metal housing, so the shield is continuous from the cable to the gauge housing. Do not ground the shield at the receiver or output device.

Acceptable raw cable parts:

- Belden cable 9947.
- Alpha cable 5110/15C SL005.

Acceptable connectors:

- Tyco series ADK for standard 15-pin subminiature-D connectors.
- Norcomp type 979-015-030-121.

DeviceNet cable

For DeviceNet cable, install raw cable that has a braided shield over the aluminum foil-shielded signal and power wires.

On the module end of the cable, install a metal housing, so the shield is continuous from the cable to the gauge housing. Do not ground the shield at the receiver or output device.

- Acceptable raw cable is DeviceNet shielded cable type 578 from Turck.
- Acceptable connector is CM 8151-0 metal connector from Turck.

Module power supply

Connect the module power supply to terminals 5 and 8 on the 15-pin I/O wiring connector.

- Terminal 5 (ground) is negative (-).
- Terminal 8 (input) is positive (+).

The module requires 24 Vdc $\pm 15\%$ (1.5 A current at 20.4 V), 3.0 A current at 30 W peak. Inrush current can momentarily exceed the 3.0 A peak.

Typical module operating power is 18 W for 4 mA emission when the Micro-Ion gauge is ON.

Power inputs are reverse-bias protected.

The Micro-Ion gauge will not activate and an emission error will occur if insufficient power is supplied during Micro-Ion gauge activation.

Gauge OFF/degas wiring

Install a switch between terminals 3 and 5 and between terminals 7 and 8 to enable Micro-Ion gauge degas and to switch the Micro-Ion gauge ON or OFF.

Relay, analog output, and RS-485 output wiring

- If the module has no trip point relays, see Figure 2-3.
- If the module has two trip point relays, see Figure 2-4. Relays are normally open/normally closed.
- If the module has three trip point relays, see Figure 2-5. Relays are normally open.

Relay contacts are silver alloy-gold clad, rated for 1 A at 30 Vdc. The relays can handle resistive or non-inductive loads.

Figure 2-3 Wiring terminals for Micro-Ion ATM module with RS-485 interface, one analog output, and no trip-point relays

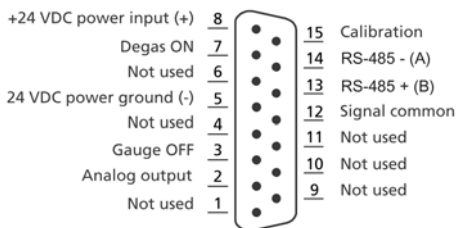

Figure 2-4 Wiring terminals for Micro-Ion ATM module with RS-485 interface, one analog output, and two trip-point relays

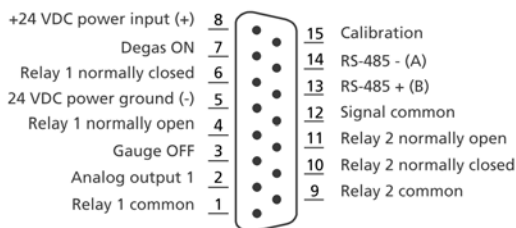
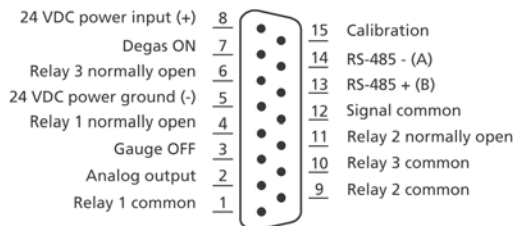

Figure 2-5 Wiring terminals for Micro-Ion ATM module with RS-485 interface, one analog output, and three trip-point relays



DeviceNet wiring

The module has a DeviceNet 5-pin micro connector for interfacing through the customer supplied DeviceNet network cable. See Figure 2-6. The DeviceNet connection is a standard 5-pin DeviceNet receptacle that accepts a standard micro 5-pin female cable connection.

The module will use terminals 2 (Vdc return) and 3 (24 Vdc) on the 5-pin DeviceNet micro connector for the network power supply.

- The DeviceNet interface requires 24 Vdc (11 to 26.4) at 0.2 A maximum.
- Maximum inrush current is 0.25 A.
- Power inputs are reverse-bias protected.

Figure 2-6 DeviceNet 5-pin micro connector

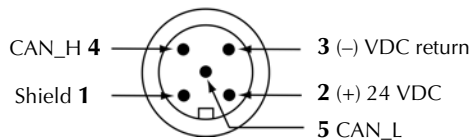

Grounding

The module contains three separate and isolated grounds: the DeviceNet ground, the analog ground, and the chassis ground.

- Typical isolation between DeviceNet and chassis grounds is 1 MΩ, up to 26 Vdc, if the DeviceNet drain is grounded.
- Above 30 Vdc the isolation approaches 0 Ω.
- The analog ground is galvanically isolated from the DeviceNet ground and the chassis ground up to 1500 V.

The module generates 180 Vdc during normal operation and 250 Vdc during Micro-Ion gauge degas.

⚠
WARNING

Improper grounding could cause severe product failure or personal injury.

Follow ground network requirements for the facility.

- Maintain all exposed conductors at earth ground.
- Ground the module housing to the vacuum chamber as illustrated below.
- Make sure the vacuum port to which the module is mounted is properly grounded.

DeviceNet grounding

The DeviceNet wiring will be properly grounded via the DeviceNet 5-pin micro connector.

Chassis ground

If the module has a VCR type fitting or ConFlat flange, the module chassis will be properly grounded via the vacuum chamber connection.

If the module has a KF flange, the module is shipped with a 3-foot length of braided copper wire, which has a screw lug on each end, and a screw and nut for connecting the copper wire to the gauge base. If a metal clamp and metal gasket will not be installed, follow this procedure to ground the module:

- a. The gauge base has a tab that allows a connection to the copper wire. Bend the tab outward from the gauge base (see Figure 2-7).
- b. Use the supplied screw and nut to connect one screw lug on the braided copper wire to the tab.
- c. Connect the other screw lug to an appropriately grounded point on the vacuum system.

Figure 2-7 Vacuum chamber ground connections

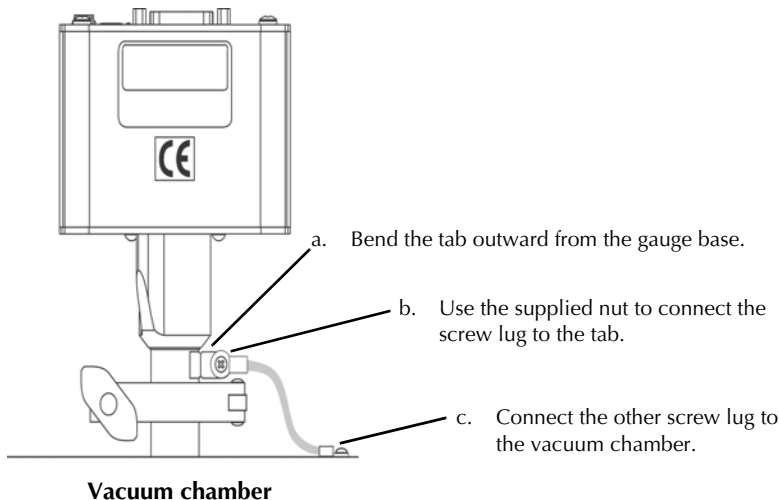

Step 4 *Calibrate module at atmospheric pressure*

- To calibrate the module at atmospheric pressure using a momentary switch installed between pins 15 and 5 on the 15-pin connector, see page 35.
- To calibrate the module at atmospheric pressure using an RS-485 command, see page 99.
- To calibrate the module at atmospheric pressure using DeviceNet explicit messaging, see page 65.

Atmospheric pressure calibration and differential pressure zero are performed at the factory before the module is shipped. The module will not operate properly unless you reset the atmospheric pressure calibration and differential pressure zero at the ambient operating pressure.

**2.4 Eliminating radio
frequency interference**

The module has been tested and found to comply with U.S. Federal Communications Commission (FCC) limits for a Class A digital device, pursuant to Part 15 of the FCC rules. These limits provide reasonable protection against harmful interference when the module operates in a commercial environment.

The module generates and can radiate radio frequency energy. If not installed and used in accordance with the instructions in this manual, the module may cause harmful interference to other electrical equipment.

Table 3-3 Tasks and page references for DeviceNet explicit messages

Task	Instructions:
Configure DeviceNet communications	Page 43
Set or get pressure unit	Page 47
Get vacuum pressure	Page 48
Get differential pressure	Page 48
Get temperature	Page 51
Set relay trip points	Page 51
Set relay activation direction	Page 51
Set relay hysteresis	Page 51
Set relay assignments	Page 51
Set disabled/enabled state of relays	Page 51
Get relay trip points	Page 55
Get disabled/enabled state of relays	Page 55
Get activation or deactivation status of relays	Page 56
Get relay hysteresis	Page 57
Get relay assignments	Page 57
Set or get Micro-Ion gauge ON/OFF state	Page 58
Set or get Micro-Ion gauge delay time	Page 59
Set or get Micro-Ion gauge filament mode	Page 60
Get Micro-Ion gauge active filament	Page 61
Set or get Micro-Ion gauge degas ON/OFF state	Page 62
Set or get emission current switch point for Micro-Ion gauge	Page 63
Calibrate module at atmospheric pressure	Page 65
Calibrate module at vacuum pressure	Page 65
Reset module to power-up state	Page 66
Get firmware version for module	Page 66
Get software and hardware revisions for module	Page 66
Get status alarms and warnings	Page 115

3.4 RS-485 operation

Table 3-4 lists tasks that may be performed using the RS-485 output.

Table 3-4 Commands, tasks, and page references for RS-485 operation

Command	Task	Instructions:
TLU	Toggle functions to locked or unlocked state	Page 80
UNL	Unlock interface functions	Page 80
SA	Set address offset	Page 81
SB	Set baud rate	Page 82
yuiop	Set RS-485 communication to default values	Page 82
SU	Set pressure unit	Page 82
RU	Read pressure unit	Page 82
SD	Set pressure indication for optional display	Page 82
RD	Read vacuum pressure	Page 83
RDD	Read differential pressure	Page 83
PC	Set or read relay trip points and activation direction	Page 84
PCG	Set relay assignments	Page 87
PCE	Set or read disabled/enabled state of relays	Page 87
RPCS	Read activation or deactivation status of relays	Page 88
IG	Set Micro-Ion gauge ON/OFF state	Page 88
IGS	Read Micro-Ion gauge ON/OFF state	Page 88
IGM	Set or read gauge and sensor ON/OFF mode	Page 89
IOD	Set Micro-Ion gauge delay ON/OFF state	Page 90
IDT	Set Micro-Ion gauge delay time	Page 91
SF	Set Micro-Ion gauge filament mode	Page 92
RF	Read Micro-Ion gauge filament status	Page 96
DG	Set Micro-Ion gauge degas ON/OFF state	Page 96
DGS	Read Micro-Ion gauge degas ON/OFF state	Page 96
DGT	Set or read Micro-Ion gauge degas time	Page 97
SER	Set emission current switch point for Micro-Ion gauge	Page 97
RE	Read Micro-Ion gauge emission current	Page 99
TS	Calibrate module at atmospheric pressure	Page 99
TZ	Calibrate module at vacuum pressure	Page 100
ATM	Set or read atmospheric pressure indicated by analog and RS-485 outputs	Page 101
RS	Read RS-485 character strings indicating module status	Page 101
RSX	Read 8-digit hexadecimal codes indicating module status	Page 103
RST	Reset module to power-up state	Page 105
FAC	Reset values to factory defaults	Page 106
VER	Read firmware version for module	Page 106

3.5 Automatic filament selection

As the vacuum system pumps down from atmosphere, the Conductron sensor measures pressure until a sufficiently low pressure level is achieved, then automatically turns ON the Micro-Ion gauge. The filaments in the Micro-Ion gauge can burn out if they turn ON at a pressure that is too high. Tungsten filaments are more likely than yttria-coated iridium filaments to burn out if they turn ON at a pressure that is too high. To reduce the risk of burnout, the default behavior of Micro-Ion gauge depends on the filament material.

If a rapid increase in pressure from high vacuum levels to pressures of 1 Torr (1.33 mbar, 133 Pa) or higher pressure occurs, tungsten filaments are almost certain to burn out. This risk is not unique to the Micro-Ion gauge and exists for all ion gauges containing tungsten filaments.

- At startup, the module software detects the filament material and sets the behavior of the Micro-Ion gauge accordingly, as listed in Table 3-5.
- If the gauge assembly is replaced, the module software automatically sets the behavior of the Micro-Ion gauge according to the filament material.
- For RS-485 communications, you can use the IOD, IDT, and SF commands to change the behavior of the Micro-Ion gauge. See pages 90–92.
- For DeviceNet communications, you can use explicit messages to change the behavior of the Micro-Ion gauge. See pages 60–61.

Table 3-5 Defaults for Micro-Ion gauge filament material

Function	Default for tungsten filaments	Default for yttria-coated iridium filaments
Micro-Ion gauge delay time	Module software determines the appropriate amount of time to wait before the Micro-Ion gauge turns ON with decreasing pressure	Micro-Ion gauge turns ON, without delay, as soon as operational pressure is achieved with decreasing pressure.
Micro-Ion gauge added delay time	Micro-Ion gauge waits an additional 2 seconds, beyond software-defined delay time, to turn ON with decreasing pressure.	
Micro-Ion gauge filament mode	Manual (see page 60 or page 94).	Alternating (see page 60 or page 95).

Chapter 4 Analog Operation

4.1 Output functions

The module has a DeviceNet interface, an RS-485 interface, and one analog output. The analog output represents vacuum pressure.

The analog output does not operate independently but must operate with the DeviceNet or RS-485 interface.



WARNING

Using the module to measure the pressure of flammable or explosive gases can cause a fire or explosion resulting in severe property damage, personal injury, or death.

Do not use the module to measure the pressure of flammable or explosive gases.

4.2 Preparing to operate the module

Before putting the module into operation, you must perform the following procedures:

1. Install the module in accordance with the instructions on pages 15–24.
2. Develop a logic diagram of the process control function.
3. Develop a circuit schematic that specifies exactly how each piece of system hardware will connect to the module relays.
4. Attach a copy of the process control circuit diagram to this manual for future reference and troubleshooting.

If you need application assistance, phone a Granville-Phillips application engineer at **1-303-652-4400** or **1-800-776-6543** within the USA, or email co-csr@brooks.com.

4.3 Operational tasks

Once the module is operating, you may perform the tasks listed in Table 3-1 on page 25.

4.4 LED status indicator

- Figure 4-1 illustrates the LED status indicator on the top of the housing. The LED behavior indicates the status of the module and Micro-Ion gauge.
- Table 4-1 lists states indicated by the LED.

Figure 4-1 LED status indicator

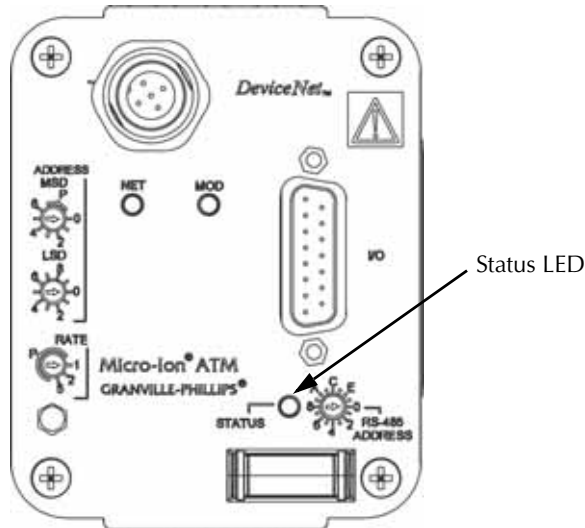

Table 4-1 LED status indications

LED behavior	Indicated condition:
OFF	Module power supply is OFF
Solid green	Power is ON, Micro-Ion gauge is OFF
Blinking green	Micro-Ion gauge is ON
Solid amber	Micro-Ion gauge is ON but one filament is inoperable
Blinking amber	<ul style="list-style-type: none"> • Both Micro-Ion gauge filaments are inoperable; replace gauge assembly • Electronics may be defective; return module to factory

4.5 Reading pressure

Use the module's 15-pin connector to read voltage that indicates vacuum pressure.

- Output impedance is 100 Ω .
- The voltage across pins 2 (analog output 1) and 12 (signal common) represents vacuum pressure, as illustrated in Figure 4-2. Use one of the following equations to calculate vacuum pressure as a function of voltage:

$$P \text{ vacuum}_{\text{Torr}} = 10^{[(2 \times V_{\text{out}}) - 11]}$$

$$P \text{ vacuum}_{\text{mbar}} = 1.33 \times 10^{[(2 \times V_{\text{out}}) - 11]}$$

$$P \text{ vacuum}_{\text{Pa}} = 133 \times 10^{[(2 \times V_{\text{out}}) - 11]}$$

Voltage is in linear proportion to the logarithm of vacuum pressure. For example, a vacuum pressure of 1×10^{-3} Torr (1.33×10^{-3} mbar, 1.33×10^{-1} Pa) produces a 4 Vdc analog output, as illustrated in Figure 4-3.

Figure 4-2 Pins 2 and 12: Voltage indicating vacuum pressure

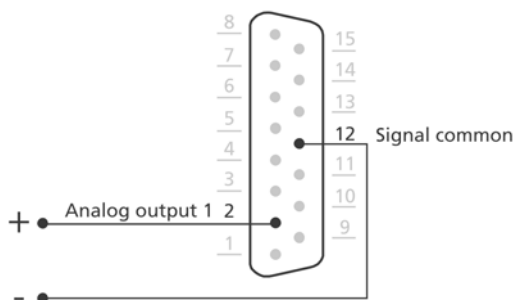
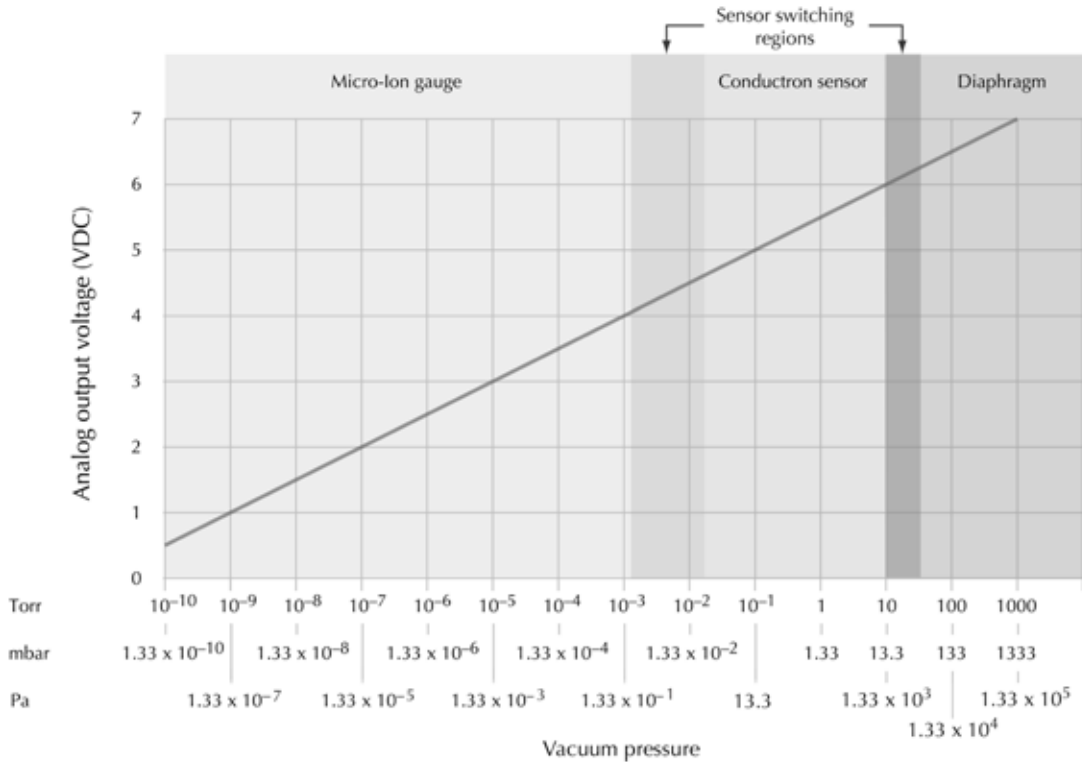

Figure 4-3 Analog output indicating vacuum pressure



4.6 Micro-Ion gauge OFF

When power is supplied to the module, the Conduction sensor is ON. As pressure decreases to a level that allows the Micro-Ion gauge to operate, the sensor automatically turns the gauge ON. The LED status indicator blinks green when the Micro-Ion gauge is ON. In some instances, you might need to turn the Micro-Ion gauge OFF.

- If the module does not have RS-485 communications, the module outputs pressure values from the Conduction sensor when the Micro-Ion gauge is OFF.
- If the module has RS-485 communications, you may program the module to turn OFF all pressure outputs when the Micro-Ion gauge is OFF or to output pressure values from the Conduction sensor when the Micro-Ion gauge is OFF (see page 89).

If the Micro-Ion gauge has tungsten filaments and one filament fails, you must turn the gauge OFF, then back ON to switch to the other filament.

To turn the Micro-Ion gauge OFF and ON, install a switch between pins 5 (24 Vdc power ground) and 3 (gauge OFF) on the 15-pin connector, as illustrated in Figure 4-5.

- Close the switch to turn the gauge OFF.
- Open the switch to turn the gauge ON.

Figure 4-4 Pins 5 and 3: Switch for Micro-Ion gauge OFF

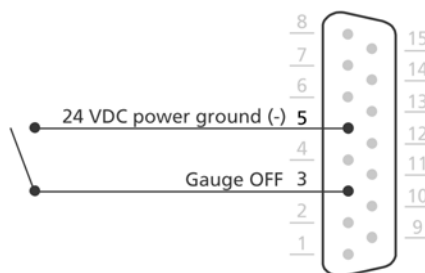

4.7 Micro-Ion gauge degas

To enable initiation and termination of the degas cycle for the Micro-Ion gauge, install a switch between pins 8 (24 Vdc power input) and 7 (degas ON) on the 15-pin connector, as illustrated in Figure 4-4.

- Close the switch between pins 8 and 7 to initiate the degas cycle. After initiation, the degas cycle continues for two minutes.
- The degas cycle ends immediately if you open the switch.
- During degas the module continues to output a pressure signal, but the indicated value may be affected by the degas function and indicate a less accurate pressure.

Figure 4-5 Pins 8 and 7: Switch for Micro-Ion gauge degas ON

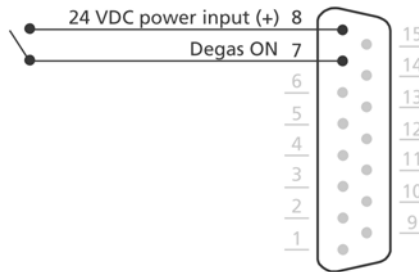

4.8 Calibration

You may install a momentary contact switch between pins 15 (calibration) and 5 (24 Vdc power ground) to enable calibration at atmospheric or vacuum pressure. See Figure 4-6.

Figure 4-6 Pins 15 and 5: Switch for calibration

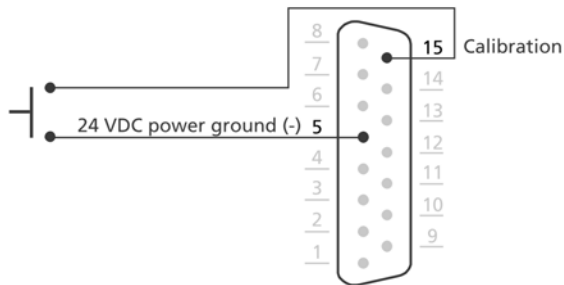

Atmospheric pressure calibration

Atmospheric pressure calibration and differential pressure zero are performed using N₂ at the factory before the module is shipped. Differential pressure zero is the pressure value at which atmospheric and vacuum pressures are equal. The factory calibration sets the differential pressure zero to approximately 760 Torr (1013 mbar, 1.01 x 10⁵ Pa). The module will not operate properly unless you reset the atmospheric pressure calibration and differential pressure zero at the ambient operating pressure.

If the atmospheric pressure calibration value is too low, the Micro-Ion gauge will not turn ON.

Use N₂ or air to calibrate the module at atmospheric pressure. Minimum valid calibration pressure is 500 Torr (666 mbar, 6.66 x 10⁴ Pa).

1. To ensure accurate calibration, make sure the differential pressure sensor is vented and open to atmosphere when you calibrate the module at atmospheric pressure.
2. Shut the pump OFF and, using N₂ or air, allow the vacuum pressure to increase until it equals atmospheric pressure.
3. Momentarily close the switch between pins 15 and 5.

Vacuum pressure calibration

Ordinarily, the Conductron sensor turns the Micro-Ion gauge ON when pressure decreases to 2 x 10⁻² Torr (2.66 x 10⁻² mbar, 2.66 Pa). However, if the Conductron sensor calibration has shifted so that the Micro-Ion gauge cannot turn ON, you can recalibrate the module for vacuum pressure.

Use N₂ or air to calibrate the module at vacuum pressure. Maximum valid calibration pressure is 3.00 x 10⁻² Torr (3.99 x 10⁻² mbar, 3.99 Pa).

1. Turn the pump ON and, using N₂ or air, allow the vacuum chamber to decrease to the optimal calibration pressure of 1 x 10⁻⁴ Torr (1.33 x 10⁻⁴ mbar, 1.33 x 10⁻² Pa) or a lower pressure.
2. Momentarily close the switch between pins 15 and 5.

Chapter 5 DeviceNet Operation

5.1 Pressure output and relay functions

The module has a DeviceNet interface, an RS-485 interface, and one analog output.

- The analog output represents vacuum chamber pressure.
- The module may have no trip point relays, two trip point relays, or three trip point relays. The relays may represent vacuum pressure or differential pressure.

You may use polled I/O or explicit messages to read vacuum pressure or differential pressure, assign trip point relays to vacuum pressure or differential pressure, and configure the module.



WARNING

Using the module to measure the pressure of flammable or explosive gases can cause a fire or explosion resulting in severe property damage, personal injury, or death.

Do not use the module to measure the pressure of flammable or explosive gases.

5.2 Preparing to operate the module

Before putting the module into operation, you must perform the following procedures:

1. Install the module in accordance with the instructions on pages 15–24.
2. Develop a logic diagram of the process control function.
3. Develop a circuit schematic that specifies exactly how each piece of system hardware will connect to the module relays.
4. Attach a copy of the process control circuit diagram to this manual for future reference and troubleshooting.
5. If the module has two or three trip point relays, use Table 5-1 to record the proposed activation and deactivation trip points (in Torr, mbar, or Pa) and assignments for each relay.

If you need application assistance, phone a Granville-Phillips application engineer:

- Phone **1-303-652-4400** or **1-800-776-6543** within the USA.
- Phone **1-800-367-4887** 24 hours per day, seven days per week within the USA.
- Email co-csr@brooks.com

Table 5-1 Relay trip points and assignments

Relay	Activation trip point (Torr, mbar, or Pa)	Deactivation trip point (Torr, mbar, or Pa)	Relay assignment
Relay 1			<input type="checkbox"/> Vacuum pressure <input type="checkbox"/> Differential pressure
Relay 2			<input type="checkbox"/> Vacuum pressure <input type="checkbox"/> Differential pressure
Relay 3 (if present)			<input type="checkbox"/> Vacuum pressure <input type="checkbox"/> Differential pressure

5.3 Performance with DeviceNet protocol

Table 5-2 lists performance characteristics for the Micro-Ion ATM module using DeviceNet protocol.

Table 5-2 Micro-Ion ATM module performance characteristics with DeviceNet protocol

Network feature	Performance			
Network size	Up to 64 nodes (00 to 63)			
Network length	End-to-end network distance varies with speed			
	<table border="1"> <tr> <td>Baud rate</td> <td>Distance</td> </tr> <tr> <td> <ul style="list-style-type: none"> • 125 kbaud • 250 kbaud • 500 kbaud </td> <td> <ul style="list-style-type: none"> • 1,640 feet (500 m) • 820 feet (250 m) • 328 feet (100 m) </td> </tr> </table>	Baud rate	Distance	<ul style="list-style-type: none"> • 125 kbaud • 250 kbaud • 500 kbaud
Baud rate	Distance			
<ul style="list-style-type: none"> • 125 kbaud • 250 kbaud • 500 kbaud 	<ul style="list-style-type: none"> • 1,640 feet (500 m) • 820 feet (250 m) • 328 feet (100 m) 			
Bus topology	<ul style="list-style-type: none"> • Linear (trunkline/dropline) • Power and signal on the same network cable 			
Bus addressing	<ul style="list-style-type: none"> • Peer-to-peer with multi-cast (one-to-many) • Multi-master and master/slave special case • Polled or change-of-state (exception-based) 			
System features	<ul style="list-style-type: none"> • Module can be removed and replaced while network power supply is ON • Module can be programmed while network power supply is ON (program changes will take effect after power has been cycled) 			

5.4 DeviceNet protocol for the Micro-Ion ATM module

The Micro-Ion ATM module is based on the Open DeviceNet Vendors Association (ODVA) and S-Analog Sensor Object Class Subclass 01 (Instance Selector) standards. The Micro-Ion ATM module command set includes public and vendor-specific classes, services, and attributes.

DeviceNet communication requires identifier fields for the data. The use of identifier fields provides the means for multiple priority levels, efficient transfer of I/O data, and multiple consumers. As a node in the network, the module produces data on the network with a unique address. All devices on the network that need the data listen for messages. When other devices on the network recognize the module's unique address, they use the data.

For a complete list of DeviceNet messages used by the module, see *Appendix B*. The instructions in this chapter explain how to use the module command set to operate the module.

5.5 Operational tasks

DeviceNet protocol conveys three types of messages, as defined in Table 5-3.

Once the module is operating, you may use polled I/O or explicit messages to perform the tasks listed in Table 3-2 and Table 3-3.

Table 5-3 DeviceNet message types

Message type	Message purpose
Polled I/O messages	<ul style="list-style-type: none"> Used for time critical, control oriented data Provide a dedicated, special purpose communication path between a producing application and one or more consuming applications
Change of state I/O messages	<ul style="list-style-type: none"> Used for time critical, control oriented data Data transfer initiated by the producing application Provide a dedicated, special purpose communication path between a producing application and one or more consuming applications
Explicit messages	<ul style="list-style-type: none"> Provide multipurpose, point-to-point communication paths between two devices Provide typical request/response oriented network communications used for performing node configuration and problem diagnosis

5.6 DeviceNet switches and indicators

Address switches

The module has address switches for setting the network address and a data rate switch for setting the baud rate.

Use the address switches to set the media access control identifier (MAC ID), which the network master uses to address the module. When the device powers up or is reset by the network, the device firmware will read the address switch settings. Figure 5-1 illustrates the address switches.

Specific address values range from 0 to 63.

- Set the switch labeled “MSD,” to a value of 0 to 6 for the most significant (first) digit.
- Set the switch labeled “LSD,” to a value of 0 to 9 for the least significant (second) digit.

If a valid address between 0 and 63 is set, and it differs from the current address stored in non-volatile RAM (NVRAM), the new address will be saved in memory. If the data rate switch is set to the PGM setting, the firmware will use the data rate that is stored in NVRAM.

Upon connection to the DeviceNet network, the module requests a duplicate address check.

- If another device on the network has the same address as the module, the module will not join the network.
- If the address is unique, the module will join the network and the net status indicator will blink green until a connection to the master node is established.

Figure 5-1 Address switches

Valid addresses: 0 to 63

- Set most significant digit (MSD) to a value of 0 to 6
- Set least significant digit (LSD) to a value of 0 to 9

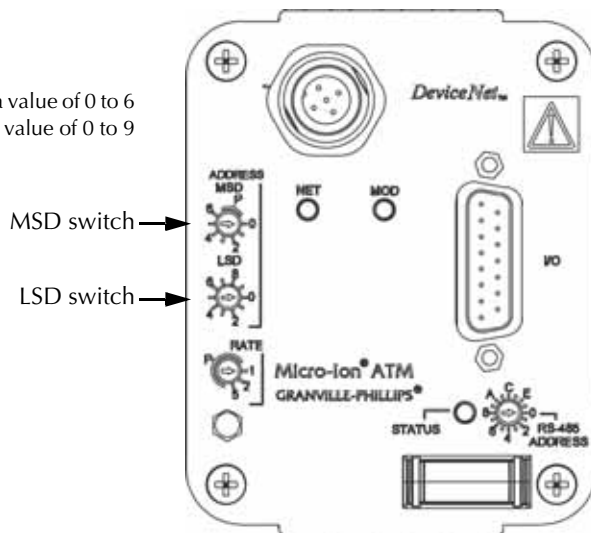

Rate switch

Use the rate switch to select the rate at which data is sent and received on the network.

- You may select a data rate of 125 kbaud (setting 1), 250 kbaud (setting 2), or 500 kbaud (setting 5).
- When the device powers up or is reset by the network, the device firmware will read the rate switch setting.

If the selected data rate differs from the value stored in NVRAM, the new data rate will be saved in memory. If the rate switch is set to the P setting, the firmware will use the data rate that is stored in NVRAM.

Figure 5-2 Rate switch**5.7 Status LEDs**

Figure 5-3 illustrates the two status LEDs, labeled NET and MOD.

- The MOD (module) status LED indicates if the module has power or is functioning properly.
- The NET (DeviceNet network) status LED indicates if the DeviceNet network has power and is functioning properly.

Table 5-4 and Table 5-5 list states for each LED and the corresponding network or module status.

Figure 5-3 Network and module status LEDs

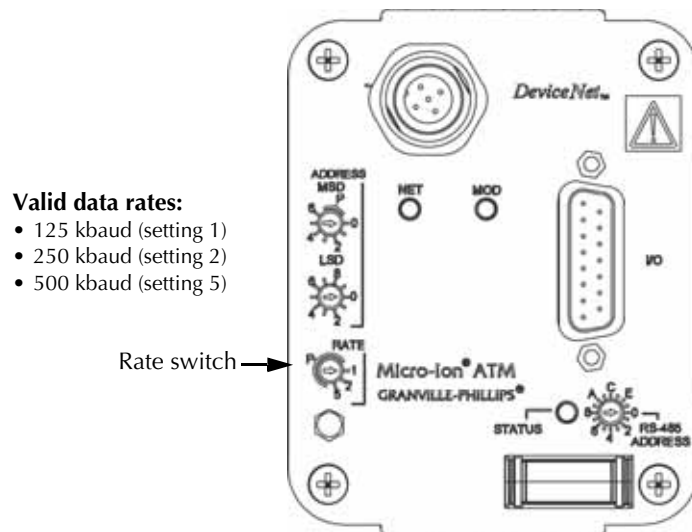
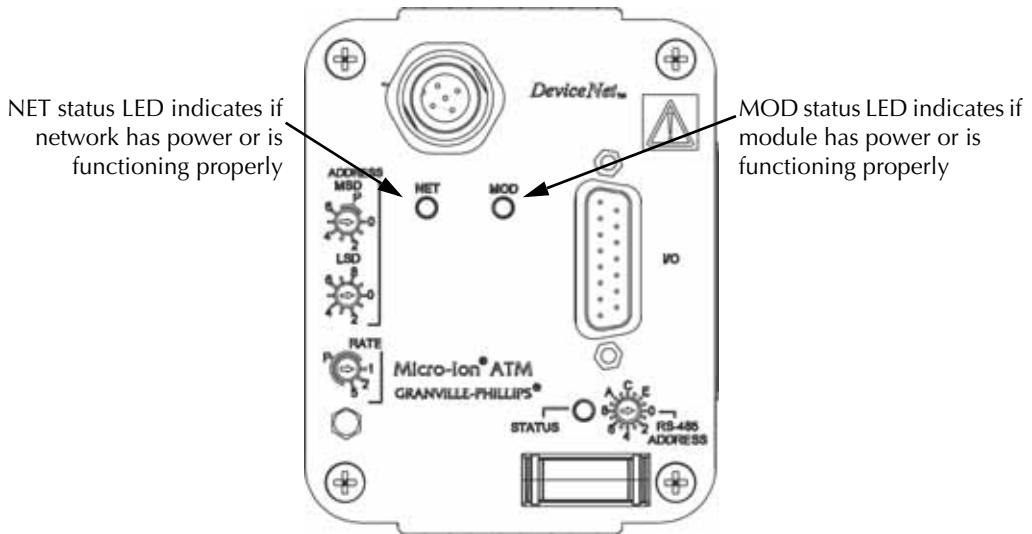

Table 5-4 NET (DeviceNet network) LED status

NET LED state	Network status	Description
OFF	Not powered	<ul style="list-style-type: none"> The module is not on line The module has not completed the DUP_MAC_ID test
Blinking green/red	Self test	Module is in self test
Blinking green	On line, not connected	The module has passed the DUP_MAC_ID test and is on line, but has not established connection with master node
Solid green	On line, connected	<ul style="list-style-type: none"> The module is allocated to a master The device is operating normally
Blinking red	Connection time out	All connections have timed out
Solid red	Critical link failure	The module has detected an error that has made it incapable of communicating on the network

Table 5-5 MOD (module) LED status

MOD LED state	Module status	Description
OFF	Power OFF	No power applied to module
Blinking green/red	Self test	Module is in self test
Solid green	Operational	Module is operating normally
Solid red	Unrecoverable fault	Module has detected a fault

- 5.8 DeviceNet communication configuration**
1. Turn the external power supply OFF.
 2. Set the address switches to the desired address (0 to 63). See page 40.
 3. Set the data rate switch to the desired setting (125, 250, or 500 kbaud). See page 41.
 4. Turn the external power supply ON.
 5. Refer to Table 5-6 and Table 5-7 to allocate a connection for the module to the network master. *You must set the bit to 1 (polled) or 0 (explicit messages) to perform tasks explained in this chapter.*
 - Set the bit contents to 1 to enable polled I/O.
 - Set the bit contents to 0 to enable explicit messages.

Table 5-6 Network master connection

Service	Class	Instance	Attribute	Data type	Allocation choice bits
4B _{hex}	3	1	None	STRUCT	0 = Explicit message 1 = Polled 2 = Bit strobed ^(a) 3 = Reserved ^(a) 4 = Change of state ^(a) 5 = Cyclic ^(a) 6 = Acknowledge suppression ^(a) 7 = Connection ^(a)

^(a) Not supported, value = 0.

Table 5-7 Network master connections allocation choice bits

Assembly number	STRUCT data: One byte format							
	Bit 7	Bit 6	Bit 5	Bit 4	Bit 3	Bit 2	Bit 1	Bit 0
1	Connection	Acknowledge suppression	Cyclic	Change of state	Reserved	Bit strobed	Polled	Explicit message

6. Refer to Table 5-8 to configure the expected packet rate for messages. The expected packet rate is the rate at which the module expects to send data to and receive a packet of data from the network.
 - The default expected packet rate for explicit messaging is 2500 msec (2.5 sec.).
 - For polled I/O, set the expected packet rate to 0 (none).
 - If data will be requested at a rate slower than every 2500 msec, you must change or disable the expected packet rate to prevent the connection from timing out.

Table 5-8 Expected packet rate**Expected packet rate for explicit messaging**

Service	Class	Instance	Attribute	Master data	Data type	Description
10 _{hex}	5	1	9	<i>data such as</i> 09 C4 _{hex} (default)	UINT	Rate at which module sends data to and receives data from network <ul style="list-style-type: none"> • Default is 2500 msec (2.5 sec.) • Valid time is ≤ 2500 msec (2.5 sec.)

Expected packet rate for polled I/O

Service	Class	Instance	Attribute	Master data	Data type	Description
10 _{hex}	5	2	9	00 00	UINT	Disable expected packet rate

7. If the connection allocation bit 1 (polled) is set at Step 5 on page 43, refer to Table 5-9 to configure the polled data input format and status byte and Table 5-10 to configure the polled data output format.
 - You may configure the module to send data to the network in integer (INT), unsigned integer (UINT), or floating point data (REAL) formats, with or without a status byte and trip point status byte.
 - The default configuration sends pressure in floating point data format with one byte of status data.

Table 5-9 Configuring polled input I/O data format

Format	Service	Class	Instance	Attribute	UINT data
2 bytes UINT vacuum pressure	10 _{hex}	4	0	65 _{hex}	01 _{hex}
1 BYTE exception status 2 bytes UINT vacuum pressure	10 _{hex}	4	0	65 _{hex}	02 _{hex}
1 BYTE exception status 1 BYTE trip point status 2 bytes UINT vacuum pressure	10 _{hex}	4	0	65 _{hex}	03 _{hex}
4 bytes REAL vacuum pressure	10 _{hex}	4	0	65 _{hex}	04 _{hex}
Default configuration: 1 BYTE exception status 4 bytes REAL vacuum pressure	10 _{hex}	4	0	65 _{hex}	05 _{hex}
1 BYTE exception status 1 BYTE trip point status 4 bytes REAL vacuum pressure	10 _{hex}	4	0	65 _{hex}	06 _{hex}
2 bytes UINT vacuum pressure 2 bytes INT differential pressure	10 _{hex}	4	0	65 _{hex}	0F _{hex}
1 BYTE exception status 2 bytes UINT vacuum pressure 2 bytes INT differential pressure	10 _{hex}	4	0	65 _{hex}	10 _{hex}
1 BYTE exception status 1 BYTE trip point status 2 bytes UINT vacuum pressure 2 bytes INT differential pressure	10 _{hex}	4	0	65 _{hex}	11 _{hex}
4 bytes REAL vacuum pressure 4 bytes REAL differential pressure	10 _{hex}	4	0	65 _{hex}	12 _{hex}
1 BYTE exception status 4 bytes REAL vacuum pressure 4 bytes REAL differential pressure	10 _{hex}	4	0	65 _{hex}	13 _{hex}
1 BYTE exception status 1 BYTE trip point status 4 bytes REAL vacuum pressure 4 bytes REAL differential pressure	10 _{hex}	4	0	65 _{hex}	14 _{hex}

Table 5-10 Configuring polled output I/O data format

Format	Service	Class	Instance	Attribute	UINT data
1 BYTE control (default)	0E _{hex}	4	0	66 _{hex}	01 hex
0 BYTE control	0E _{hex}	4	0	66 _{hex}	00 hex

8. If the connection allocation bit 1 (polled) is set at Step 5, you may configure the module to receive one byte of input data that controls the Micro-Ion gauge, as listed in Table 5-11.

Bit 6 in the one byte format turns the Micro-Ion gauge ON or OFF. If bit 6 is set to 1, the gauge will turn ON. See Table 5-12.

Table 5-11 Writing gauge and sensor ON/OFF bits using output polled I/O

Assembly number	USINT data: One byte format							
	Bit 7	Bit 6	Bit 5	Bit 4	Bit 3	Bit 2	Bit 1	Bit 0
1	0	Gauge ON or OFF	0	0	0	0	0	Initiate or terminate Micro-Ion gauge degas

Table 5-12 Gauge and sensor ON/OFF bits

Bit	Gauge control function	Description
Bits 0, 1, 2, 3, 4, 5, and 7	Reserved	Must be set to 0 (zero)
Bit 6	Micro-Ion gauge ON/OFF	<ul style="list-style-type: none"> • If bit 6 is set to 1, gauge will turn ON • If a fault occurs, gauge will turn OFF and an alarm will generate (see page 115) • After the alarm has been cleared, set this bit to 0, then reset to 1 to restart gauge

5.9 Pressure units and values

You may use explicit messages to set the pressure unit.

You may use explicit messages or input polled I/O to read values that represent measured pressure. You must calculate measured pressure from the values represented by the explicit message or input polled I/O.

If you get pressure using input polled I/O or from the assembly object using explicit messaging, values are available with or without warning and alarm status or trip point status.

Set or get pressure unit

Use the explicit messages listed in Table 5-13 to set or get the unit of pressure.

Table 5-13 Pressure measurement units

Service	Class	Instance	Attribute	Typical device data	Data type	Description
0E _{hex}	31 _{hex}	1	4	01 03	UINT	Get pressure unit
10 _{hex}	31 _{hex}	1	4	01 03	UINT	Set pressure unit <ul style="list-style-type: none"> • 769 = Torr • 776 = mbar • 777 = Pascal

Data conversion

Refer to Table 5-14 to convert explicit message or input polled I/O data to meaningful values representing exception status, trip point status, vacuum pressure, or differential pressure.

Table 5-14 Converting BYTE, UINT, INT, or REAL data to exception status, trip point status, or pressure values

Represented value	Data type	Converting data to exception status, trip point status, or pressure value
Exception status	BYTE	8-bit string, from most significant to least significant bit: <ul style="list-style-type: none"> • Bit 1 = Alarm • Bit 5 = Warning
Trip point status	BYTE	8-bit string, from most significant to least significant bit: <ul style="list-style-type: none"> • Bit 0 = Relay 1 is activated • Bit 1 = Relay 2 is activated • Bit 2 = Micro-Ion gauge emission current is 4.0 mA (high emission)
Vacuum pressure	UINT	16-bit unsigned integer value from 0 to 65535, from integer count: $\text{Vacuum pressure} = 10^{(\text{Integer counts}/2000) - 12.6249}$
Differential pressure	INT	2-byte (16-bit) integer value from -32767 to +32767, from integer count: $\text{Differential pressure} = \frac{\text{Integer counts}}{10}$
Vacuum pressure or differential pressure	REAL	32-bit floating point value in single precision IEEE 754 format, in pressure unit defined by the user (Torr, mbar, or Pa).

Get vacuum pressure or differential pressure

You may use explicit messages or input polled I/O to read values that represent measured pressure. You must calculate measured pressure from the values represented by the explicit message or input polled I/O.

If you get pressure using input polled I/O or from the assembly object using explicit messaging, values are available with or without warning and alarm status or trip point status.

Using DeviceNet explicit messages:

You may read measured pressure in the assembly object, analog sensor object (instance 0), analog sensor object Conductron sensor (instance 1), analog sensor object Micro-Ion gauge (instance 2), or analog sensor object differential pressure (instance 3).

- The explicit messages for each object are listed in Table 5-15.
- You *must* refer to Table 5-14 to convert the BYTE, UINT, INT, or REAL data to meaningful values representing exception status, trip point status, vacuum pressure, or differential pressure.

Table 5-15 Explicit messages for measured pressure values

Pressure values are transmitted in low byte to high byte order.

Service	Class	Instance	Attribute	Typical device data	Data type	Description
0E _{hex}	31 _{hex}	0	5E _{hex}	00 00 3E 44 _{hex}	REAL	Get REAL vacuum pressure (760 Torr)
0E _{hex}	31 _{hex}	1	6	00 00 3E 44 _{hex}	REAL	Get REAL vacuum pressure from Conductron sensor (760 Torr)
0E _{hex}	31 _{hex}	2	6	BD 37 86 35 _{hex}	REAL	Get REAL vacuum pressure from Micro-Ion gauge (1 x 10 ⁻⁶ Torr)
0E _{hex}	31 _{hex}	3	6	00 00 80 BF _{hex}	REAL	Get REAL differential pressure (-1 Torr)
0E _{hex}	4	1	3	23 79 _{hex}	UINT	Get UINT vacuum pressure (760 Torr)
0E _{hex}	4	2	3	00 23 79 _{hex}	STRUCT	Get BYTE exception status Get UINT vacuum pressure
0E _{hex}	4	3	3	00 00 23 79 _{hex}	STRUCT	Get BYTE exception status Get BYTE trip point status Get UINT vacuum pressure
0E _{hex}	4	4	3	00 00 3E 44 _{hex}	REAL	Get REAL vacuum pressure (760 Torr)
0E _{hex}	4	5	3	00 00 00 3E 44 _{hex}	STRUCT	Get BYTE exception status Get REAL vacuum pressure
0E _{hex}	4	0F _{hex}	3	2379 _{hex} F6 FF _{hex} 00 00 00 00	UINT INT	Get UINT vacuum pressure (760 Torr) Get INT differential pressure (-1 Torr) Placeholders
0E _{hex}	4	10 _{hex}	3	00 2379 _{hex} F6 FF _{hex} 00 00 00 00	BYTE UINT INT	Get BYTE exception status Get INT vacuum pressure Get INT differential pressure Placeholders
0E _{hex}	4	11 _{hex}	3	00 00 2379 _{hex} F6 FF _{hex} 00 00 00 00	BYTE BYTE UINT INT	Get BYTE exception status Get BYTE trip point status Get UINT vacuum pressure Get INT differential pressure Placeholders
0E _{hex}	4	12 _{hex}	3	00 00 3E 44 _{hex} 00 00 80 BF _{hex} 00 00 00 00 00 00 00	REAL REAL	Get REAL vacuum pressure Get REAL differential pressure Placeholders
0E _{hex}	4	13 _{hex}	3	00 00 00 3E 44 _{hex} 00 00 80 BF _{hex} 00 00 00 00 00 00 00 00	BYTE REAL REAL REAL	Get BYTE exception status Get REAL vacuum pressure Get REAL differential pressure Placeholders
0E _{hex}	4	14 _{hex}	3	00 00 00 00 3E 44 _{hex} 00 00 80 BF _{hex} 00 00 00 00 00 00 00 00	BYTE BYTE REAL REAL	Get BYTE exception status Get BYTE trip point status Get REAL vacuum pressure Get REAL differential pressure Placeholders

Using input polled I/O:

When a master polls the module for measured pressure, the format of the returned pressure value depends on the data type. See Table 5-16.

- To configure the data format for input polled I/O, see Step 7 on page 44.
- You *must* refer to Table 5-14 to convert the BYTE, UINT, INT, or REAL data to meaningful values representing exception status, trip point status, vacuum pressure, or differential pressure.

Table 5-16 Input polled I/O for pressure values

Pressure values are transmitted in low byte to high byte order.

Instance	Typical device data	Data type	Description
1	23 79 _{hex}	UINT	UINT vacuum pressure (760 Torr)
2	00 23 79 _{hex}	STRUCT	BYTE exception status UINT vacuum pressure
3	00 00 23 79 _{hex}	STRUCT	BYTE exception status BYTE trip point status UINT vacuum pressure
4	00 00 3E 44 _{hex}	REAL	REAL vacuum pressure
5 (default)	00 00 00 3E 44 _{hex}	STRUCT	BYTE exception status REAL vacuum pressure (760 Torr)
0F _{hex}	2379 _{hex} F6 FF _{hex} 00 00 00 00	UINT INT	UINT vacuum pressure (760 Torr) INT differential pressure (-1 Torr) Placeholders
10 _{hex}	00 2379 _{hex} F6 FF _{hex} 00 00 00 00	BYTE UINT INT	BYTE exception status UINT vacuum pressure INT differential pressure Placeholders
11 _{hex}	00 00 2379 _{hex} F6 FF _{hex} 00 00 00 00	BYTE BYTE UINT INT	BYTE exception status BYTE trip point status UINT vacuum pressure INT differential pressure Placeholders
12 _{hex}	00 00 3E 44 _{hex} 00 00 80 BF _{hex} 00 00 00 00 00 00 00 00	REAL REAL	REAL vacuum pressure REAL differential pressure Placeholders
13 _{hex}	00 00 00 3E 44 _{hex} 00 00 80 BF _{hex} 00 00 00 00 00 00 00 00	BYTE REAL REAL	BYTE exception status REAL vacuum pressure REAL differential pressure Placeholders
14 _{hex}	00 00 00 00 3E 44 _{hex} 00 00 80 BF _{hex} 00 00 00 00 00 00 00 00	BYTE BYTE REAL REAL	BYTE exception status BYTE trip point status REAL vacuum pressure REAL differential pressure Placeholders

5.10 Get temperature

Use the explicit messages listed in Table 5-17 to get current or maximum electronics temperature. Temperature is indicated in degrees Celsius.

Table 5-17 Current or maximum temperature

Service	Class	Instance	Attribute	Typical device data	Data type	Description
0E _{hex}	31 _{hex}	1	67 _{hex}	25 00	UINT	Get maximum internal temperature
0E _{hex}	31 _{hex}	1	68 _{hex}	25 00	UINT	Get current internal temperature

5.11 Process control relays

You may use explicit messages to perform the following tasks:

- Setting or getting relay trip points
- Setting or getting relay activation direction (polarity)
- Setting or getting relay hysteresis
- Setting or getting relay assignments
- Setting or getting disabled/enabled state of relays

The module may have two single-pole double-throw (normally open/normally closed) relays or three single-pole single-throw (normally open) relays. Each relay can be independently assigned to vacuum or differential pressure. Each relay has a programmable activation direction and trip point. The trip point is a value representing pressure at which the relay activates.

- When the module is shipped from the factory, relay trip points are out of range, disabled, and will not operate.
- You must configure relays to make them operable.

In default mode, trip point relays activate with decreasing pressure and deactivate at a higher pressure than the activation pressure, as illustrated in Figure 5-4.

You can reverse relay polarity, so trip point relays activate with increasing pressure and deactivate at a lower pressure than the activation pressure, as illustrated in Figure 5-5.

- You may change the deactivation pressure by entering REAL data that represents hysteresis as a percentage of the activation pressure.
- Valid hysteresis values are any activation pressure percentage, from 5% to 10,000% (absolute vacuum pressure), that is divisible by 5.

Use the explicit messages listed in Table 5-19 to configure trip point relays.

Figure 5-4 Default behavior of relays activating with decreasing pressure

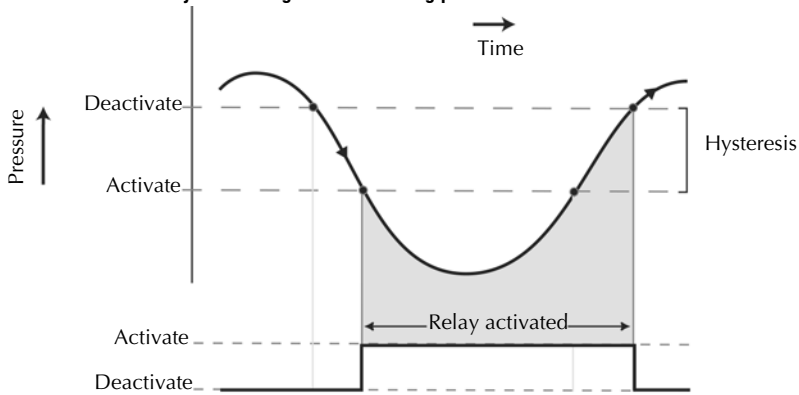

Figure 5-5 Default behavior of relays activating with increasing pressure

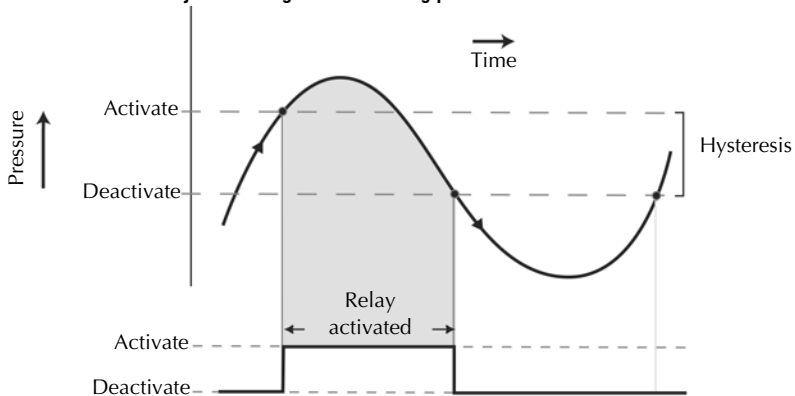

Table 5-18 lists minimum hysteresis for trip point relays based on the relay assignment.

Table 5-18 Relay assignments and minimum hysteresis

Relay assignment	Hysteresis
Vacuum pressure	5%
Differential pressure	5 Torr 6.66 mbar 666.6 Pascal

- If you assign a relay to vacuum pressure, you may change the deactivation pressure by entering REAL data that represents hysteresis as a percentage of the activation pressure.
- If you assign a relay to differential pressure, you may change deactivation pressure by entering REAL data that represents hysteresis as a differential pressure value.

Use the explicit messages listed in Table 5-19 to configure trip point relays.

Table 5-19 Trip point relay configuration commands

Trip point relay 1

Service	Class	Instance	Attribute	Typical master data	Data type	Description
10 _{hex}	35 _{hex}	1	5	BD 37 86 35 _{hex} (1 x 10 ⁻⁶)	REAL	Set pressure at which relay 1 activates.
10 _{hex}	35 _{hex}	1	6	0	BOOL	1 = Enable relay 1 0 = Disable relay 1
10 _{hex}	35 _{hex}	1	8	0	BOOL	0 = Activate with decreasing pressure. 1 = Activate with increasing pressure.
10 _{hex}	35 _{hex}	1	0A _{hex}	00 00 70 41 _{hex} (15%)	REAL	Set hysteresis <ul style="list-style-type: none"> • Percentage of activation pressure if relay 1 represents vacuum pressure. • Pressure value if relay 1 represents differential pressure. • Valid vacuum pressure hysteresis values are any activation pressure percentage, from 5% to 10,000%, that is divisible by 5. • Valid differential pressure hysteresis values are integer values from 5 to 800 Torr (6.66 to 1066 mbar, 666.6 to 2.666E+5 Pa)
10 _{hex}	35 _{hex}	1	0E _{hex}	24 00	EPATH	Set relay 1 assignment <ul style="list-style-type: none"> • 24 00= Vacuum pressure • 24 03= Differential pressure

Table 5-19 Trip point relay configuration commands (continued)

Trip point relay 2

Service	Class	Instance	Attribute	Typical master data	Data type	Description
10 _{hex}	35 _{hex}	2	5	BD 37 86 35 _{hex} (1 x 10 ⁻⁶)	REAL	Set pressure at which relay 2 activates.
10 _{hex}	35 _{hex}	2	6	0	BOOL	1 = Enable relay 2 0 = Disable relay 2
10 _{hex}	35 _{hex}	2	8	0	BOOL	0 = Activate with decreasing pressure. 1 = Activate with increasing pressure.
10 _{hex}	35 _{hex}	2	0A _{hex}	00 00 70 41 _{hex} (15%)	REAL	Set hysteresis <ul style="list-style-type: none"> Percentage of activation pressure if relay 2 represents vacuum pressure. Pressure value if relay 2 represents differential pressure. Valid vacuum pressure hysteresis values are any activation pressure percentage, from 5% to 10,000%, that is divisible by 5. Valid differential pressure hysteresis values are integer values from 5 to 800 Torr (6.66 to 1066 mbar, 666.6 to 2.666E+5 Pa).
10 _{hex}	35 _{hex}	2	0E _{hex}	24 00	EPATH	Set relay 2 assignment <ul style="list-style-type: none"> 24 00= Vacuum pressure 24 03= Differential pressure

Trip point relay 3

Service	Class	Instance	Attribute	Typical master data	Data type	Description
10 _{hex}	35 _{hex}	3	5	BD 37 86 35 _{hex} (1 x 10 ⁻⁶)	REAL	Set pressure at which relay 3 activates.
10 _{hex}	35 _{hex}	3	6	0	BOOL	1 = Enable relay 3 0 = Disable relay 3
10 _{hex}	35 _{hex}	3	8	0	BOOL	0 = Activate with decreasing pressure. 1 = Activate with increasing pressure.

Table 5-19 Trip point relay configuration commands (continued)

10 _{hex}	35 _{hex}	3	0A _{hex}	00 00 70 41 _{hex} (15%)	REAL	Set hysteresis <ul style="list-style-type: none"> • Percentage of activation pressure if relay 3 represents vacuum pressure. • Pressure value if relay 3 represents differential pressure. • Valid vacuum pressure hysteresis values are any activation pressure percentage, from 5% to 10,000%, that is divisible by 5. • Valid differential pressure hysteresis values are integer values from 5 to 800 Torr (6.66 to 1066 mbar, 666.6 to 2.666E+5 Pa).
10 _{hex}	35 _{hex}	3	0E _{hex}	24 00	EPATH	Set relay 3 assignment <ul style="list-style-type: none"> • 24 00= Vacuum pressure • 24 03= Differential pressure

Get relay trip points

Use the explicit messages listed in Table 5-20 to get the pressure value at which a relay activates.

Table 5-20 Relay trip points

Service	Class	Instance	Attribute	Typical device data	Data type	Description
0E _{hex}	35 _{hex}	1	5	BD 37 86 35 _{hex} (1 x 10 ⁻⁶)	REAL	Get pressure at which relay 1 activates
0E _{hex}	35 _{hex}	2	5	BD 37 86 35 _{hex} (1 x 10 ⁻⁶)	REAL	Get pressure at which relay 2 activates
0E _{hex}	35 _{hex}	3	5	BD 37 86 35 _{hex} (1 x 10 ⁻⁶)	REAL	Get pressure at which relay 3 activates

Get enable/disable status of relays

Use the explicit messages listed in Table 5-21 to get the enabled or disabled status of a relay.

After relays have been made operable, you may use explicit messages to disable any specified relay. If you disable a relay, you must re-enable it to make it operable. You must reconfigure the relay to re-enable it. See pages 51–54.

Table 5-21 Relay enabled/disabled status

Service	Class	Instance	Attribute	Typical device data	Data type	Description
0E _{hex}	35 _{hex}	1	6	0	BOOL	0 = Relay 1 is disabled 1 = Relay 1 is enabled
0E _{hex}	35 _{hex}	2	6	0	BOOL	0 = Relay 2 is disabled 1 = Relay 2 is enabled
0E _{hex}	35 _{hex}	3	6	0	BOOL	0 = Relay 3 is disabled 1 = Relay 3 is enabled

**Get activation or
deactivation status of
relays**

Use the explicit messages listed in Table 5-22 to get the activation or deactivation state of a relay.

Table 5-22 Relay activation/deactivation status

Service	Class	Instance	Attribute	Typical device data	Data type	Description
0E _{hex}	35 _{hex}	1	7	0	BOOL	0 = Relay 1 is deactivated 1 = Relay 1 is activated
0E _{hex}	35 _{hex}	2	7	0	BOOL	0 = Relay 2 is deactivated 1 = Relay 2 is activated
0E _{hex}	35 _{hex}	3	7	0	BOOL	0 = Relay 3 is deactivated 1 = Relay 3 is activated

Get relay hysteresis

Use the explicit messages listed in Table 5-23 to get the hysteresis for a relay.

- The returned value is a percentage of activation pressure if the relay represents vacuum pressure.
- The returned value is a pressure value if the relay represents differential pressure.

Table 5-23 Relay hysteresis

Service	Class	Instance	Attribute	Typical device data	Data type	Description
0E _{hex}	35 _{hex}	1	0A _{hex}	00 00 70 41 _{hex} (15%)	REAL	<ul style="list-style-type: none"> • Percentage of activation pressure if relay 1 represents vacuum pressure • Pressure value if relay 1 represents differential pressure
0E _{hex}	35 _{hex}	2	0A _{hex}	00 00 70 41 _{hex} (15%)	REAL	<ul style="list-style-type: none"> • Percentage of activation pressure if relay 2 represents vacuum pressure • Pressure value if relay 2 represents differential pressure
0E _{hex}	35 _{hex}	3	0A _{hex}	00 00 70 41 _{hex} (15%)	REAL	<ul style="list-style-type: none"> • Percentage of activation pressure if relay 3 represents vacuum pressure • Pressure value if relay 3 represents differential pressure

Get relay assignments

Use the explicit messages listed in Table 5-24 to get the assignment for a relay.

Table 5-24 Relay assignments

Service	Class	Instance	Attribute	Typical device data	Data type	Description
0E _{hex}	35 _{hex}	1	0F _{hex}	00 00 24 00	REAL	Get input data from analog sensor object <ul style="list-style-type: none"> • 24 00 = Relay 1 is assigned to vacuum pressure • 24 03 = Relay 1 is assigned to differential pressure
0E _{hex}	35 _{hex}	2	0F _{hex}	00 00 24 00	REAL	Get input data from analog sensor object <ul style="list-style-type: none"> • 24 00 = Relay 2 is assigned to vacuum pressure • 24 03 = Relay 2 is assigned to differential pressure
0E _{hex}	35 _{hex}	3	0F _{hex}	00 00 24 00	REAL	Get input data from analog sensor object <ul style="list-style-type: none"> • 24 00 = Relay 2 is assigned to vacuum pressure • 24 03 = Relay 2 is assigned to differential pressure

5.12 Micro-Ion gauge controls

You may use explicit messages to perform the following tasks:

- Turning the Micro-Ion gauge ON or OFF
- Getting the Micro-Ion gauge ON/OFF state
- Setting or getting the Micro-Ion gauge delay time
- Setting or getting the Micro-Ion gauge filament mode
- Getting the Micro-Ion gauge active filament
- Setting or getting the Micro-Ion gauge degas ON or OFF state
- Setting the emission current switch point for Micro-Ion gauge

You may use polled I/O to perform the following tasks:

- Turning the Micro-Ion gauge OFF
- Initiating or terminating the Micro-Ion gauge degas

Turn Micro-Ion gauge ON or OFF

When the module starts up, the Conductron sensor is ON. As pressure decreases to a level that allows the Micro-Ion gauge to operate, the sensor turns the gauge ON. In some instances, you might need to turn the Micro-Ion gauge OFF.

You may use explicit messages or polled I/O to turn the Micro-Ion gauge OFF or ON.

Using DeviceNet explicit messages:

Use the explicit message listed in Table 5-25 to turn the Micro-Ion gauge OFF or ON.

Table 5-25 Micro-Ion gauge ON/OFF command

Service	Class	Instance	Attribute	Typical master data	Data type	Description
62 _{hex}	31 _{hex}	2	None	0	USINT	Set Micro-Ion gauge ON/OFF state <ul style="list-style-type: none"> • 0 = Turn Micro-Ion gauge OFF • 1 = Turn Micro-Ion gauge ON

Using input polled I/O:

The master can input data to the device to turn the Micro-Ion gauge OFF or ON. See Table 5-11 and Table 5-12 on page 46.

Get Micro-Ion gauge ON/OFF status

Use the explicit message listed in Table 5-26 to get the Micro-Ion gauge ON/OFF status.

Table 5-26 Micro-Ion gauge ON/OFF status

Service	Class	Instance	Attribute	Typical device data	Data type	Description
0E _{hex}	31 _{hex}	2	5D _{hex}	0	BOOL	0 = Micro-Ion gauge is OFF 1 = Micro-Ion gauge is ON

Set or get Micro-Ion gauge delay time

Use the explicit message listed in Table 5-27 to reduce the possibility that the Micro-Ion gauge filaments will burn out if the gauge turns ON at a pressure that is too high. The UINT value of the master data represents the amount of time the Micro-Ion gauge waits to turn ON after pressure has decreased to a point where the gauge can operate.

If the gauge contains tungsten filaments, the number of seconds specified by the UINT data is *added to* the time the module software has determined that the Micro-Ion gauge should wait to turn ON with decreasing pressure, as expressed in the following equation:

$$\text{Total time delay} = \text{Time}_{\text{Startup}} + \text{Time}_{\text{UINT data value}}$$

If the gauge contains yttria-coated iridium filaments, the number of seconds specified by the UINT data is the *exact amount* of time that the Micro-Ion gauge will wait to turn ON with decreasing pressure.

During the delay, outputs indicate pressure as measured by the Conductron sensor.

If the gauge assembly is replaced, the module software automatically sets the Micro-Ion gauge delay time according to the filament material.

- If the replacement gauge contains tungsten filaments, the Micro-Ion gauge waits an additional 2 seconds, beyond software-defined delay time, to turn ON with decreasing pressure.
- If the replacement gauge contains yttria-coated iridium filaments, the Micro-Ion gauge turns ON, without delay, as soon as operational pressure is achieved with decreasing pressure.

If the UINT data value is not 0, within the pressure range of 1.00×10^{-3} to 3.00×10^{-2} Torr (1.33×10^{-3} to 39.9×10^{-2} mbar, 1.33 to 3.99 Pa), the pressure output might not be within the specified accuracy of $\pm 15\%$ of reading.

Whether or not the UINT data value is 0, some signal fluctuation occurs if the Micro-Ion gauge has tungsten filaments.

Table 5-27 Micro-Ion gauge delay time command

Service	Class	Instance	Attribute	Typical master data	Data type	Description
10 _{hex}	31 _{hex}	2	6A _{hex}	C8 _{hex} (200)	UINT	Set Micro-Ion gauge delay time, 0 to 600 sec.

Use the explicit message listed in Table 5-28 to get the Micro-Ion gauge delay time.

Table 5-28 Micro-Ion gauge delay time

Service	Class	Instance	Attribute	Typical device data	Data type	Description
0E _{hex}	31 _{hex}	2	6A _{hex}	C8 _{hex} (200)	UINT	Micro-Ion gauge delay time

Set or get filament mode

The Micro-Ion gauge contains two filaments. The filaments can operate in automatic, alternating, or manual mode.

Table 5-29 describes operation of the filaments in automatic, alternating, and manual modes.

Table 5-29 Micro-Ion gauge filament modes

Filament mode	Description
Manual (default for Micro-Ion gauge with tungsten filaments)	<ul style="list-style-type: none"> Filament 1 operates each time the Micro-Ion gauge turns ON. If filament 1 is inoperable, turn Micro-Ion gauge OFF, then ON to switch to filament 2. If both filaments are inoperable, Micro-Ion gauge turns OFF and outputs indicate pressure as measured by Conductron sensor.
Alternating (default for Micro-Ion gauge with yttria-coated iridium filaments)	<ul style="list-style-type: none"> Operation alternates between filament 1 and filament 2 each time Micro-Ion gauge turns ON. If one filament is inoperable, Micro-Ion gauge operates using the other filament. If both filaments are inoperable, Micro-Ion gauge turns OFF and outputs indicate pressure as measured by Conductron sensor.
Automatic	<ul style="list-style-type: none"> Filament 1 operates each time Micro-Ion gauge turns ON. If filament 1 is inoperable, Micro-Ion gauge switches to filament 2. If both filaments are inoperable, Micro-Ion gauge turns OFF and outputs indicate pressure as measured by Conductron sensor.
Both	<ul style="list-style-type: none"> Filament 1 filament 2 operate simultaneously. If one of the filaments does not turn ON, the Micro-Ion gauge operates using the other filament. If both filaments are inoperable, the Micro-Ion gauge turns OFF.

Use the explicit message listed in Table 5-30 to set the filament to automatic, alternating, or manual mode.

- If the Micro-Ion gauge has yttria-coated iridium filaments, the default filament mode is alternating.
- If the Micro-Ion gauge has tungsten filaments, the default filament mode is manual.

Table 5-30 Filament mode commands

Service	Class	Instance	Attribute	Typical master data	Data type	Description
10 _{hex}	31 _{hex}	2	69 _{hex}	0	USINT	Set filament mode <ul style="list-style-type: none"> • 0 = Automatic • 1 = Alternating • 2 = Manual

Use the explicit message listed in Table 5-31 to get the filament mode.

Table 5-31 Filament mode

Service	Class	Instance	Attribute	Typical device data	Data type	Description
0E _{hex}	31 _{hex}	2	69 _{hex}	0	USINT	0 = Automatic 1 = Alternating 2 = Manual

Get active filament

Use the explicit message listed in Table 5-32 to get the active filament.

Table 5-32 Active filament

Service	Class	Instance	Attribute	Typical device data	Data type	Description
0E _{hex}	31 _{hex}	2	59 _{hex}	0	USINT	Bit 0 = Filament 1 Bit 1 = Filament 2

**Initiate or terminate
Micro-Ion gauge degas**

You may use explicit messages or polled I/O to initiate or terminate the Micro-Ion gauge degas cycle.

Using DeviceNet explicit messages:

To degas the Micro-Ion gauge, follow these steps:

1. Turn the Micro-Ion gauge OFF. (See page 58.)
2. Make sure vacuum pressure is lower than 5×10^{-5} Torr (6.66×10^{-5} mbar, 6.66×10^{-3} Pa).
3. Refer to Table 5-33 and set the command bit to 1 (ON) to initiate the degas cycle. The time for gauge degas is two minutes.
4. *If you wish to terminate the Micro-Ion gauge degas cycle before it is completed, set the command bit to 0 (OFF).*

Table 5-33 Micro-Ion gauge degas commands

Service	Class	Instance	Attribute	Typical master data	Data type	Description
61 _{hex}	31 _{hex}	2	None	0	USINT	Set Micro-Ion degas state <ul style="list-style-type: none"> • 0 = Terminate degas cycle • 1 = Initiate degas cycle

Using output polled I/O:

The master can input data to the device to turn the degas function ON or OFF. Table 5-34 displays the polled output I/O one byte format. Table 5-35 lists degas control bits.

Bit 0 in the one byte format starts the Micro-Ion gauge degas cycle. If bit 0 is changed from 0 to 1, degas will start when the gauge is ON and pressure is lower than 5×10^{-6} Torr (6.66×10^{-6} mbar, 6.66×10^{-4} Pa).

Table 5-34 Writing Micro-Ion gauge degas bits

Assembly number	USINT data: One byte format								
	Bit 7	Bit 6	Bit 5	Bit 4	Bit 3	Bit 2	Bit 1	Bit 0	
1	0	Gauge ON or OFF	0	0	0	0	0	0	<ul style="list-style-type: none"> • 0 = Terminate degas cycle • 1 = Initiate degas cycle

Table 5-35 Micro-Ion gauge degas control bits

Bit	Gauge control function	Description
Bits 0 and 6	Degas	<ul style="list-style-type: none"> Set bit 6 to 1 to turn ON gauge (gauge <i>must</i> be ON to initiate gauge degas) If bit 0 is changed from 0 to 1, degas will initiate if Micro-Ion gauge is ON and pressure is lower than 5×10^{-5} Torr (6.66×10^{-5} mbar, 6.66×10^{-3} Pa)
Bits 1, 2, 3, 4, 5, and 7	Reserved	Should always be 0 (zero)

Get Micro-Ion gauge degas ON/OFF state

Use the explicit message listed in Table 5-36 to get the Micro-Ion gauge degas state.

Table 5-36 Micro-Ion gauge degas state

Service	Class	Instance	Attribute	Typical device data	Data type	Description
0E _{hex}	31 _{hex}	2	58 _{hex}	0	USINT	<ul style="list-style-type: none"> 0 = Degas is ON (in progress) 1 = Degas is OFF

Set or get Micro-Ion gauge emission current

The Micro-Ion gauge can operate at either of two emission current levels.

- In low-emission mode, the current level is 20 μ A.
- In high-emission mode, the current level is 4 mA.

As the vacuum pump removes gas from the system, the Conductron sensor measures pressure until it has decreased to a pressure at which the Micro-Ion gauge can operate. At this gauge pressure, the Conductron sensor turns the Micro-Ion gauge ON at the low emission current level (20 μ A).

As pressure continues to decrease, the Micro-Ion gauge switches from low emission current to high emission current (4 mA). If pressure increases after the current level has gone from low to high, the gauge switches back to low emission current. Table 5-37 lists default, minimum, and maximum pressure values at which the gauge switches emission current levels.

Table 5-37 Micro-Ion gauge emission current pressure values

Emission current setting	Minimum switch points	Default switch points	Maximum switch points
Switch to high emission current (4 mA) with decreasing pressure	5×10^{-8} Torr 6.66×10^{-8} mbar 6.66×10^{-6} Pa	5×10^{-6} Torr 6.66×10^{-6} mbar 6.66×10^{-4} Pa	3×10^{-4} Torr 4×10^{-4} mbar 4×10^{-2} Pa
Switch to low emission current(0.02 mA with increasing pressure	1×10^{-7} Torr 1.33×10^{-7} mbar 1.33×10^{-5} Pa	1×10^{-5} Torr 1.33×10^{-5} mbar 1.33×10^{-3} Pa	6×10^{-4} Torr 8×10^{-4} mbar 8×10^{-2} Pa

The switch back to low emission current with increasing pressure is 100% greater than the switch to high emission current with decreasing pressure, as illustrated in Figure 5-6. For example, in default mode, the current level switches from low to high emission at 5×10^{-6} Torr (6.66×10^{-6} mbar, 6.66×10^{-4} Pa), then switches back to low emission at 1×10^{-5} Torr (1.33×10^{-5} mbar, 1.33×10^{-3} Pa).

Figure 5-6 Example emission current switch points

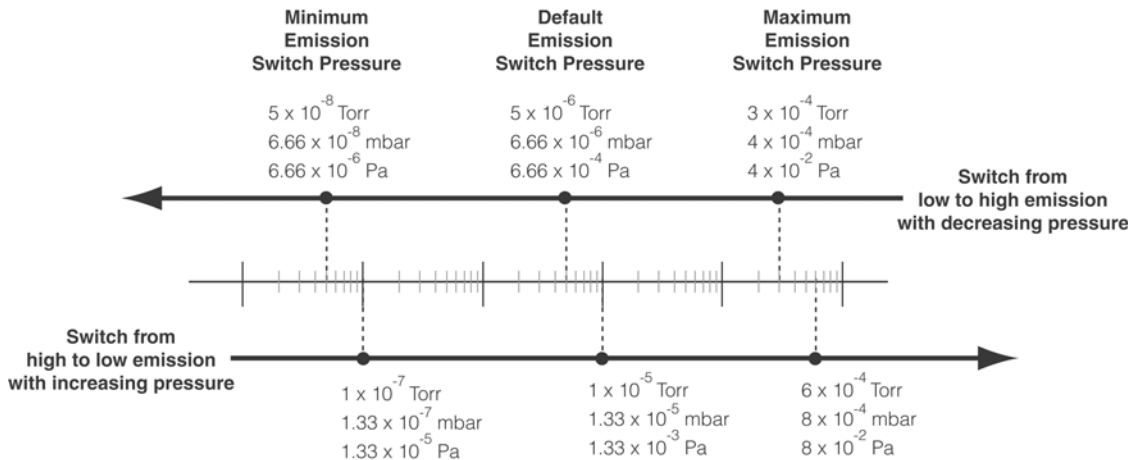

Use the explicit message listed in Table 5-38 to adjust the pressure value at which the Micro-Ion gauge switches from high emission (4.0 mA) to low emission (20 μ A) with increasing pressure.

Table 5-38 Emission current switch point command

Service	Class	Instance	Attribute	Typical master data	Data type	Description
10 _{hex}	35 _{hex}	4	5	AC C5 A7 36 _{hex} (5×10^{-6} Torr)		SET emission current switch point, emission ranging (5×10^{-6} Torr)

Use the explicit command listed in Table 5-39 to get the emission current switch point.

Table 5-39 Emission current switch point

Service	Class	Instance	Attribute	Typical device data	Data type	Description
0E _{hex}	35 _{hex}	4	5	AC C5 A7 36 _{hex} (5×10^{-6} Torr)	REAL	GET emission current switch point, emission ranging (5×10^{-6} Torr)

- 5.13 Calibrate module at atmospheric pressure**
- Atmospheric pressure calibration and differential pressure zero are performed using N₂ at the factory before the module is shipped. Differential pressure zero is the pressure value at which atmospheric and vacuum pressures are equal. The factory calibration sets the differential pressure zero to approximately 760 Torr (1013 mbar, 1.01 x 10⁵ Pa). The module will not operate properly unless you reset the atmospheric pressure calibration and differential pressure zero at the ambient operating pressure.
- If the atmospheric pressure calibration value is too low, the Micro-Ion gauge will not turn ON.
- Use N₂ or air to calibrate the module at atmospheric pressure. Minimum valid calibration pressure is 500 Torr (666 mbar, 6.66 x 10⁴ Pa).
1. To ensure accurate calibration, make sure the differential pressure sensor is vented and open to atmosphere when you calibrate the module at atmospheric pressure.
 2. Shut the pump OFF and, using N₂ or air, allow the vacuum pressure to increase until it equals atmospheric pressure.
 3. Use the explicit message listed in Table 5-40 to perform the atmospheric pressure calibration. Set the command bit to 1.
- 5.14 Calibrate module at vacuum pressure**
- Ordinarily, the Conduccion sensor turns the Micro-Ion gauge ON when pressure decreases to 2×10^{-2} Torr (2.66×10^{-2} mbar, 2.66 Pa). However, if the Conduccion sensor calibration has shifted so that the Micro-Ion gauge cannot turn ON, you can recalibrate the module for vacuum pressure.
- Use N₂ or air to calibrate the module at vacuum pressure. Maximum valid calibration pressure is 3.00×10^{-2} Torr (3.99×10^{-2} mbar, 3.99 Pa).
1. Turn the pump ON and, using N₂ or air, allow the vacuum chamber to decrease to the optimal calibration pressure of 1×10^{-4} Torr (1.33×10^{-4} mbar, 1.33 x 10⁻² Pa) or a lower pressure.
 2. Use the explicit message listed in Table 5-40 to perform the vacuum pressure calibration. Set the command bit to 0.

Table 5-40 Vacuum pressure or atmospheric pressure calibration command

Service	Class	Instance	Attribute	Master data	Data type	Description
4B _{hex}	31 _{hex}	1	None	None	None	Calibrate module at vacuum pressure
4C _{hex}	31 _{hex}	1	None	None	None	Calibrate module at atmospheric pressure

- 5.15 Reset module to power-up state** Use the explicit message listed in Table 5-41 to reset the module to power-up status.
- Resetting the module to power-up status has the same effect as cycling power to the module. Communication is re-enabled two seconds after you've sent the explicit message.

Table 5-41 Reset to power-up state command

Service	Class	Instance	Attribute	Master data	Data type	Description
05 _{hex}	1	1	None	None	None	Reset module to power-up state

- 5.16 Get firmware version** Use the explicit messages listed in Table 5-42 to get the firmware version for the module.

Table 5-42 Firmware version command

Service	Class	Instance	Attribute	Device data	Data type	Description
0E _{hex}	1	1	4	01 01	None	Get firmware version

- 5.17 Get software and hardware revision levels** Use the explicit messages listed in Table 5-43 to get the software and hardware revision levels for the module.

Table 5-43 Software and hardware revision commands

Service	Class	Instance	Attribute	Device data	Data type	Description
0E _{hex}	30 _{hex}	1	7	"1.01"	SSTRING	Get software revision level
0E _{hex}	30 _{hex}	1	8	"1.01"	SSTRING	Get hardware revision level

5.18 Factory defaults

Micro-Ion ATM modules are shipped with the default settings listed in Table 5-44. If options in your application require settings different from the factory defaults listed in Table 5-44, you may change the settings.

- Some settings can be changed only through the DeviceNet interface.
- You may reconfigure options before or after completing the basic setup procedures described in this chapter.

Table 5-44 Factory default settings

Parameter	Default setting
Digital communication	Baud rate: 500 kbaud
Vacuum calibration pressure	1×10^{-4} Torr (1.33×10^{-4} mbar, 1.33×10^{-2} Pa)
Atmospheric calibration pressure	760 Torr (1013 mbar, 1.01×10^5 Pa)
Differential pressure zero	760 Torr (1013 mbar, 1.01×10^5 Pa)
Relay 1 trip point	Disabled
Relay 2 trip point	Disabled
Relay 3 trip point	Disabled
Trip point polarity	<ul style="list-style-type: none"> • 10% hysteresis • Polarity default set for decreasing pressure
Micro-Ion gauge filament mode	<ul style="list-style-type: none"> • Alternating for yttria-coated iridium filaments • Manual for tungsten filaments
Micro-Ion gauge emission current switch point	<ul style="list-style-type: none"> • With decreasing pressure: 5×10^{-6} Torr 6.66×10^{-6} mbar 6.66×10^{-4} Pa • With increasing pressure: 1×10^{-5} Torr 1.33×10^{-5} mbar 1.33×10^{-3} Pa
Unit of measure	As specified by the catalog number: <ul style="list-style-type: none"> • T = Torr • M = mbar • P = Pascal

5.19 DeviceNet error codes You may use DeviceNet explicit messages or polled I/O to find out if an alarm or warning has been reported. To select polled I/O or explicit messages, see page 43.

Using polled I/O An alarm or warning is indicated by the status byte in the input assembly, instance 2 or instance 5. An alarm is bit weight 1, and a warning is bit weight 5, as listed in Table 5-45.

Table 5-45 Module alarm and warning status for polled I/O

Instance	BYTE data: One byte format							
2 or 5	Bit 7 0	Bit 6 0	Bit 5 Warning	Bit 4 0	Bit 3 0	Bit 2 0	Bit 1 Alarm	Bit 0 0

Using explicit messages Alarms, warnings, and status messages are available from the objects listed in Table 5-46.

For detailed information about alarms, warnings, and status messages, see pages 69–72.

Table 5-46 DeviceNet explicit messages indicating alarms, warning, or status

Object	Service	Class	Instance	Attribute
Identity object	0E _{hex}	1	1	5
Device supervisor object	0E _{hex}	30 _{hex}	1	0C _{hex}
Analog sensor object, instance 1, Conductron sensor	0E _{hex}	31 _{hex}	1	5
Analog sensor object, instance 1, Conductron sensor	0E _{hex}	31 _{hex}	1	7
Analog sensor object, instance 2, Micro-Ion gauge	0E _{hex}	31 _{hex}	2	5
Analog sensor object, instance 2, Micro-Ion gauge	0E _{hex}	31 _{hex}	2	7
Analog sensor object, instance 2, Micro-Ion gauge	0E _{hex}	31 _{hex}	2	5E _{hex}
Analog sensor object, instance 2, Micro-Ion gauge	0E _{hex}	31 _{hex}	2	5F _{hex}
Analog sensor object, instance 2, Micro-Ion gauge	0E _{hex}	31 _{hex}	2	60 _{hex}
Analog sensor object, instance 3, differential pressure	0E _{hex}	31 _{hex}	3	5
Analog sensor object, instance 3, differential pressure	0E _{hex}	31 _{hex}	3	7

Table 5-47 Status and fault information from identity object

Service	Class	Instance	Attribute	Typical device data	Data type	Description
0E _{hex}	1	1	5	00 00	WORD	Status and fault information

Troubleshooting status and fault information

Instance	Attribute	Bit	Cause	Solution
1	5	0	An object is allocated.	No solution necessary.
1	5	2	Device is configured.	No solution necessary.
1	5	8	<ul style="list-style-type: none"> Module cannot be calibrated at atmospheric pressure. Module cannot be calibrated at vacuum pressure. 	<ul style="list-style-type: none"> If module cannot be calibrated at atmospheric pressure, make sure vacuum pressure = atmospheric pressure, then recalibrate (see page 65). If module cannot be calibrated at vacuum pressure, make sure vacuum pressure $\leq 1 \times 10^{-4}$ Torr (1.33×10^{-4} mbar, 1.33×10^{-2} Pa), then recalibrate (see page 65).
1	5	11	<ul style="list-style-type: none"> Conductron sensor or pressure diaphragm sensor is inoperable. Micro-Ion gauge grid voltage or emission failure. 	<p>If Conductron sensor or pressure diaphragm sensor is inoperable, replace gauge assembly (see page 118).</p> <p>If Micro-Ion gauge grid voltage failure or emission failure has occurred, cycle power to module.</p>

Table 5-48 Exception status from device supervisor object

Service	Class	Instance	Attribute	Typical device data	Data type	Description
0E _{hex}	30 _{hex}	1	0C _{hex}	0	BYTE	Get exception status

Troubleshooting exception status

Instance	Attribute	Bit	Cause	Solution
1	0C _{hex}	1	<ul style="list-style-type: none"> Conductron sensor or pressure diaphragm sensor is inoperable. Micro-Ion gauge grid voltage or emission failure. 	<ul style="list-style-type: none"> If Conductron sensor or pressure diaphragm sensor is inoperable, replace gauge assembly (see page 118). If Micro-Ion gauge grid voltage failure or emission failure has occurred, cycle power to module.
1	0C _{hex}	5	<ul style="list-style-type: none"> Module cannot be calibrated at atmospheric pressure. Module cannot be calibrated at vacuum pressure. 	<ul style="list-style-type: none"> If module cannot be calibrated at atmospheric pressure, make sure vacuum pressure = atmospheric pressure, then recalibrate (see page 65). If module cannot be calibrated at vacuum pressure, make sure vacuum pressure $\leq 1 \times 10^{-4}$ Torr (1.33×10^{-4} mbar, 1.33×10^{-2} Pa), then recalibrate (see page 65).

Table 5-49 Reading valid, status, alarm, and warning information from analog sensor object, instance 1, Conductron sensor

Service	Class	Instance	Attribute	Typical device data	Data type	Description
0E _{hex}	31 _{hex}	1	5	1	BOOL	Get reading valid, 0 or 1
0E _{hex}	31 _{hex}	1	7	0	BYTE	Get status, alarm or warning

Troubleshooting reading valid, status, alarm, and warning information

Instance	Attribute	Bit	Cause	Solution
1	5	0	Reading is valid, Conductron sensor is operating normally.	0 = Get status from instance 1, attribute 7. 1 = No solution necessary.
1	7	0	Conductron sensor is inoperable.	Replace gauge assembly (see page 118).
1	7	1	Conductron sensor is operating normally.	No solution necessary.
1	7	2	Module cannot be calibrated at atmospheric pressure.	Make sure vacuum pressure = atmospheric pressure, then recalibrate (see page 65).
1	7	3	Module cannot be calibrated at vacuum pressure.	Make sure vacuum pressure $\leq 1 \times 10^{-4}$ Torr (1.33×10^{-4} mbar, 1.33×10^{-2} Pa), then recalibrate (see page 65).

Table 5-50 Reading valid, status, alarm, and warning information from analog sensor object, instance 2, Micro-Ion gauge

Service	Class	Instance	Attribute	Typical device data	Data type	Description
0E _{hex}	31 _{hex}	2	5	1	BOOL	Get reading valid, 0 or 1
0E _{hex}	31 _{hex}	2	7	0	BYTE	Get status, alarm or warning
0E _{hex}	31 _{hex}	2	5E _{hex}	0	BYTE	Filament 1 or 2 is open
0E _{hex}	31 _{hex}	2	5F _{hex}	0	BYTE	High-voltage or emission failure
0E _{hex}	31 _{hex}	2	60 _{hex}	0	BYTE	Reading invalid <ul style="list-style-type: none"> • 0 = No solution necessary. • 1 = Get status from instance 2, attribute 7.

Troubleshooting reading valid, status, alarm, and warning information

Instance	Attribute	Bit	Cause	Solution
2	5	0	Reading is valid, Micro-Ion gauge is ON and operating normally.	No solution necessary.
2	7	0	Micro-Ion gauge grid voltage or emission failure.	Cycle power to module.
2	5E _{hex}	0	Filament 1 is open.	Switch to the other filament. <ul style="list-style-type: none"> • If filament mode is alternating or automatic, turn Micro-Ion gauge ON (see page 58). • If filament mode is manual, turn Micro-Ion gauge OFF, then ON (see page 58).
2	5E _{hex}	1	Filament 2 is open.	Switch to the other filament. <ul style="list-style-type: none"> • If filament mode is alternating or automatic, turn Micro-Ion gauge ON (see page 58). • If filament mode is manual, turn Micro-Ion gauge OFF, then ON (see page 58).
2	5F _{hex}	Byte 0, bit 0	Micro-Ion gauge emission failure.	Cycle power to module.
2	5F _{hex}	Byte 0, bit 1	Micro-Ion gauge emission failure.	Cycle power to module.
2	5F _{hex}	Byte 1, bit 4	Micro-Ion gauge high-voltage failure.	Cycle power to module.
2	60 _{hex}	0	Reading invalid.	0 = No solution necessary. 1 = Get status from instance 2, attribute 7.

Table 5-51 Reading valid, status, alarm, and warning information from analog sensor object, instance 3, differential pressure

Service	Class	Instance	Attribute	Typical device data	Data type	Description
0E _{hex}	31 _{hex}	3	5	1	BOOL	Get reading valid, 0 or 1
0E _{hex}	31 _{hex}	3	7	0	BYTE	Get status, alarm or warning

Troubleshooting reading valid, status, alarm, and warning information

Instance	Attribute	Bit	Cause	Solution
3	5	0	Reading is valid, differential pressure sensors are operating normally.	No solution necessary.
3	7	0	Diaphragm pressure sensor failure.	0 = No solution necessary. 1 = Replace gauge assembly (see page 118).
3	7	2	Module cannot be calibrated at atmospheric pressure.	0 = No solution necessary. 1 = Make sure vacuum pressure = atmospheric pressure, then recalibrate (see page 65).
3	7	3	Module cannot be calibrated at vacuum pressure.	Make sure vacuum pressure $\leq 1 \times 10^{-4}$ Torr (1.33×10^{-4} mbar, 1.33×10^{-2} Pa), then recalibrate (see page 65).

Chapter 6 RS-485 Operation

6.1 Pressure output and relay functions

The module has a DeviceNet interface, an RS-485 interface, and one analog output.

- The analog output represents vacuum chamber pressure.
- The module may have no trip point relays, two trip point relays, or three trip point relays. The relays may represent vacuum pressure or differential pressure.

You may use RS-485 commands to read vacuum pressure or differential pressure, assign trip point relays to vacuum pressure or differential pressure, and configure the module.



WARNING

Using the module to measure the pressure of flammable or explosive gases can cause a fire or explosion resulting in severe property damage, personal injury, or death.

Do not use the module to measure the pressure of flammable or explosive gases.

6.2 Preparing to operate the module

Before putting the module into operation, you must perform the following procedures:

1. Install the module in accordance with the instructions on pages 15–24.
2. Develop a logic diagram of the process control function.
3. Develop a circuit schematic that specifies exactly how each piece of system hardware will connect to the module relays.
4. Attach a copy of the process control circuit diagram to this manual for future reference and troubleshooting.
5. If the module has two or three trip point relays, use Table 6-1 to record the proposed activation and deactivation trip points (in Torr, mbar, or Pascal) and assignments for each relay.

If you need application assistance, phone a Granville-Phillips application engineer at 1-303-652-4400 or 1-800-776-6543 within the USA, or email co-csr@brooks.com.

Table 6-1 Relay trip points and assignments

Relay	Activation trip point (Torr, mbar, or Pa)	Deactivation trip point (Torr, mbar, or Pa)	Relay assignment
Relay 1			<input type="checkbox"/> Vacuum pressure <input type="checkbox"/> Differential pressure
Relay 2			<input type="checkbox"/> Vacuum pressure <input type="checkbox"/> Differential pressure
Relay 3 (if present)			<input type="checkbox"/> Vacuum pressure <input type="checkbox"/> Differential pressure

6.3 RS-485 physical layer Table 6-2 lists specifications for the RS-485 physical layer.

Table 6-2 RS-485 physical layer specifications

Function	Description
Arrangement	2-wire half duplex
Address range	0 to 63
Default address	01
Method for setting 00 to 30 _{hex} value in address	Use SA command (see page 81)
Method for setting 0 to F _{hex} offset value in address	Use address switch (see page 81)
Maximum cable length	<ul style="list-style-type: none"> • 4000 feet (1610 meters) • A common ground wire should connect all network devices for long cable runs
Maximum number of devices in network	32 devices
Default baud rate	19200 baud (19.2 kbaud)
Data bits	8 data bits
Stop bits and parity	1 stop bit, no parity

- 6.4 Operational tasks** Once the module is operating, you may use RS-485 commands to perform the tasks listed in Table 3-4 on page 27.
- 6.5 Error responses** If a command cannot be processed, the module returns one of the error responses listed in Table 6-3.

Table 6-3 RS-485 error responses

Response	Possible causes	Solution
RANGE ER	<ol style="list-style-type: none"> 1. Pressure value in TS calibration command is outside valid limits. 2. Pressure value in TZ calibration command is outside valid limits. 3. Pressure value in ATM set command is outside valid limits. 4. Ion gauge on-delay time (IDT) is out of range. 5. Degas duration (DGT) is out of range. 6. Emission current switch point is out of range. 7. Relay trip point is out of range (ABS). 8. Relay trip point is out of range (DIFF). 	<ol style="list-style-type: none"> 1. Make sure atmospheric pressure is > 500 Torr (666 mbar, 6.66×10^4 Pa). See page 99. 2. Make sure vacuum pressure < 3.00×10^{-2} Torr (3.99×10^{-2} mbar, 3.99 Pa). See page 100. 3. Make sure the setting is reasonable (250-1000 Torr). 4. Make sure the ion gauge delay time is between 0 and 600 seconds. 5. Make sure the degas duration setting is between 10 and 120 seconds. 6. Make sure current switch point is set correctly. See SER on page 97. 7. Make sure the trip point is between 1E-10 and 1000 Torr, and hysteresis is between 5 and 10,000%. 8. Make sure the trip point is between -800 and +300 Torr, and hysteresis is between 5 and 800 Torr.
SYNTAX ER	<ul style="list-style-type: none"> • Command was improperly entered. • Module does not recognize command syntax. • UNL command was sent when software functions were already unlocked. 	<ul style="list-style-type: none"> • Re-enter command using proper character string (see page 77).
9.99E+09	<ul style="list-style-type: none"> • Module cannot indicate a valid pressure value. • IG0 command has been sent. 	<ul style="list-style-type: none"> • Send RS or RSX command to determine module status (see page 101). • If necessary, replace the gauge assembly. • If IG0 command has been sent, send IG1 command (see page 88).
LOCKED	Interface function is locked.	<ul style="list-style-type: none"> • Send TLU or UNL command to unlock interface function (see page 80).
INVALID	<ul style="list-style-type: none"> • IG1 command sent while IG ON I/O line not asserted. • Micro-Ion gauge or Conductron sensor is defective. • Vacuum pressure is too high for gauge degas. 	<ul style="list-style-type: none"> • Assert the IG ON I/O line or disconnect from ground. • If the Micro-Ion gauge or Conductron sensor is defective, replace the gauge assembly. • Decrease the pressure to < 5×10^{-5} Torr. See DG on page 96.

6.6 Data timing and response

The module communicates using half-duplex mode. Neither the module nor the host can send and receive signals at the same time. The host issues a command then waits for a response from the module.

Figure 6-1 illustrates the request and response data timing sequence, including:

- The request sent by the host, response sent by the module.
- Minimum and maximum time duration from the end of the receipt of the request to the start of the response (T_D).
- Time required for the module to process and respond with the data (T_R).
- Time for the module to switch between transmit and receive modes (D).

Table 6-4 lists data timing and response delay limits. The time required for the module to process and send the response depends on the baud rate, as listed in Table 6-5. The minimum response time of the module to a request is 500 μ sec. The host must switch from transmit to receive mode in 500 μ sec or less to ensure proper receipt of response data packets from the module. The host must wait a minimum of 200 μ sec after receiving the response before sending a new request command.

Figure 6-1 Data timing and response delays

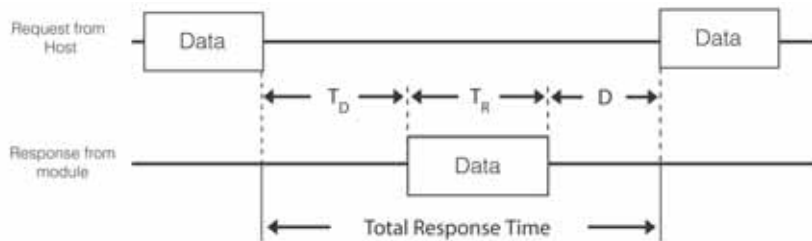

Table 6-4 Data timing and response delay limits

Timing segment	Time limit
Time T_D (time for host to switch from transmit to receive)	<ul style="list-style-type: none"> • Read commands: 500 μsec minimum, 25 msec maximum • Reset to factory defaults (FAC) command: 12.0 msec + maximum 32.0 msec
Time T_R (data processing and response time)	$\frac{1}{\text{Baud}} \times 130$
Time D (time for module to switch from transmit to receive)	200 μ sec
Total response time	Time $T_D + \left(\frac{1}{\text{Baud}} \times 130\right) + \text{Time } D$

Table 6-5 Baud rate and data typical response time

Baud rate	Data response time (T_R)
1200 baud	108 msec
2400 baud	54 msec
4800 baud	27 msec
9600 baud	13.5 msec
19200 baud (default)	6.75 msec
38400 baud	3.3 msec

6.7 RS-485 commands

RS-485 commands require entry of integer values, hex code values (such as "0F"), values in engineering notation (such as "2.00E+02"), and alphanumeric character strings.

Command structure

Table 6-6 explains the RS-485 command structure. The command should *not* include a line feed with the carriage return. Including a line feed adds an extra character and may cause a garbled response from the module.

Each response includes 13 characters, beginning with the asterisk (*) or (?) and ending with carriage return (↵).

Symbols used in this manual

The ↵ symbol at the end of the command represents the carriage return (CR), which is entered as hex code 0D or, if you're using a terminal, by simultaneously pressing the "Control" and "M" keys.

The response will have a space between the address and the text of the response. For example: *02 PROG OK↵

Table 6-6 RS-485 command structure

Address field	Command field	Data field	Carriage return
#XX	Character string for command from host	Character string data required to execute command	↵
"XX" is 2-digit address of module	First character is: <ul style="list-style-type: none"> • D = Degas • I = Ion gauge • PC = Process control • R = Read • S = Set • T = Calibrate or toggle • U = Unlock • V = Firmware version 	Data may include: <ul style="list-style-type: none"> • Hex code <i>or</i> • Pressure value in engineering notation <i>or</i> • Alphanumeric character string 	<ul style="list-style-type: none"> • Enter hex code "0D" <i>or</i> • If using a terminal, simultaneously press "Control" and "M" keys

6.8 RS-485 command set

Table 6-7 lists RS-485 commands that provide pressure values or other information without affecting module operation.

Table 6-8 on page 79 lists RS-485 commands that may affect module operation and have default values.

The instructions on pages 80–106 explain how to use the RS-485 command set to configure and operate the module.

Table 6-7 RS-485 command set for values not affecting module operation

Command	Set by command	Non-volatile	Change after reset	Data returned	Can be locked
RD	No	No	No	Vacuum pressure	No
RDD	No	No	No	Differential pressure	No
RU	No	No	No	Pressure unit	No
RPCS	No	No	No	Relay state	No
IGS	No	No	No	Micro-Ion gauge ON/OFF state	No
DGS	No	No	No	Degas ON/OFF state	No
RE	No	No	No	Emission current	No
RF	No	No	No	Filament operation state	No
RS	No	No	No	Module status RS-485 string	No
RSX	No	No	No	Module status hexadecimal bits	No
VER	No	Yes	No	Software version	No

Table 6-8 RS-485 command set for commands affecting module operation

Command	Set by command	Non-volatile	Default	Change after reset	Data returned	Can be locked
TLU	Yes	Yes	OFF (0)	No	Confirm	No
UNL	Yes	Yes	OFF (0)	No	Confirm	No
SA	Yes	Yes	00	Yes	Confirm	Yes
SB	Yes	Yes	19200 baud	Yes	Confirm	Yes
yuiop	Yes	Yes	<ul style="list-style-type: none"> • 19200 baud • Address offset 0 	No	None	No
SU	Yes	Yes	Torr	No	Confirm	Yes
SD	Yes	Yes	Absolute pressure	No	Confirm	No
PC	Yes	Yes	Out of range	No	Confirm or state	No
PCC	Yes	Yes	Disabled	No	Confirm or state	No
PCE	Yes	Yes	Disabled	No	Confirm or state	No
IG	Yes	No	ON (1)	No	Confirm or state	No
IGM	Yes	Yes	Enabled (1)	No	Confirm or state	Yes
IOD	Yes	Yes	<ul style="list-style-type: none"> • ON (1) for tungsten • OFF (0) for yttria-coated iridium 	No	Confirm or state	No
IDT	Yes	Yes	00 sec	No	Confirm or state	Yes
DG	Yes	No	OFF (0)	No	Confirm or state	No
DGT	Yes	Yes	120 sec	No	Confirm or state	No
SF	Yes	Yes	<ul style="list-style-type: none"> • Manual (MAN) for tungsten • Alternating (ALT) for yttria-coated iridium 	No	Confirm	Yes
SER	Yes	Yes	5×10^{-6} Torr 6.66×10^{-6} mbar 6.66×10^{-4} Pa	No	Confirm or state	Yes
TS	Yes	Yes	760 Torr 1013 mbar 1.01×10^5 Pa	No	Confirm	No
TZ	Yes	Yes	1×10^{-4} Torr 1.33×10^{-4} mbar 1.33×10^{-2} Pa	No	Confirm	No
ATM	Yes	Yes	760	No	Confirm or state	Yes
RST	Yes	No	Values at last power-up	Yes	None	No
FAC	Yes	Yes	Factory defaults	Yes	Confirm	Yes

TLU **Toggling locked functions** In default operating mode, all interface functions are unlocked. Use the toggle lock/unlock (TLU) command to lock or unlock any of the interface functions listed in Table 6-9.

Table 6-9 **Interface functions affected by TLU command**

Command	Interface function	Instructions:
SA	Set address offset	Page 81
SB	Set module baud rate	Page 82
SU	Set pressure unit	Page 82
IGM	Set gauge and sensor ON/OFF mode	Page 89
IDT	Set Micro-Ion gauge delay time	Page 91
DGT	Set Micro-Ion gauge degas time	Page 97
SER	Set emission current switch point for Micro-Ion gauge	Page 97
SF	Set Micro-Ion gauge filament mode	Page 92
FAC	Reset values to factory defaults	Page 106

The module processes the command, then returns a character string that indicates whether or not interface functions are unlocked.

TLU command from host: #01TLU↵
 Response from module: *01 1 UL ON↵

- The “1 UL ON” response means interface functions are locked.
- The “0 UL OFF” response means interface functions are unlocked.

UNL **Unlock interface functions** If you’ve used the TLU command to lock interface functions listed in Table 6-9, you must send the unlock interface functions (UNL) command to unlock a function before reprogramming it.

UNL command from host: #01UNL↵
 Response from module: *01 PROGM OK↵

- If you send the UNL command while interface functions are already unlocked, the module returns a “SYNTAX ER” response (see page 75).
- You can unlock all locked functions by sending the TLU command.
- If you attempt to reprogram a locked function without sending the UNL or TLU command, the module returns a “ LOCKED” response (see page 75).

SA Set address offset

You *must* assign an address to enable the module to communicate with the host. The module may use any address from 0 to 63.

The address consists of the hexadecimal switch setting plus the hexadecimal SA (set address offset) value. For example, to set a value of 60 for the address, set the switch to C_{hex} (12), then send an SA value of 30_{hex} (48).

To set the address, follow these steps:

1. Use the rotary switch located on the top of the module to set a value of 0 to 15 (see Figure 6-2).
 - Set the switch on one of the unlabeled marks for the values 1, 3, 5, 7, 9, B_{hex} (11), D_{hex} (13), or F_{hex} (15).
 - Set the switch on one of the labeled marks for the values 0, 2, 4, 6, 8, A_{hex} (10), C_{hex} (12), or E_{hex} (14).
2. Send an SA (set address offset) command to the module.
3. Cycle power to the module.

The example SA command sets the address to 60 if the switch is set to C:

Example SA command from host: #01SA30␣

Response from module: *01 PROGM OK␣

Valid SA command values are 00, 10_{hex} (16), 20_{hex} (32), or 30_{hex} (48).

Figure 6-2 Address switch

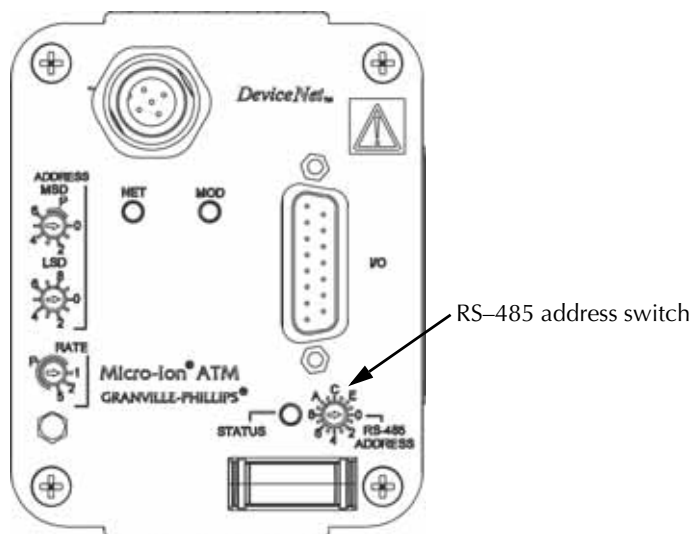

SB	Set baud rate	<p>The example set baud rate (SB) command sequence sets the baud rate to 2400 baud:</p> <p>Example SB command from host: #01SB2400↵ Response from module: *01 PROGM OK↵</p> <p>Valid values are 1200, 2400, 4800, 9600, 19200 (default), or 38400 baud.</p>
yuiop	Restore RS-485 communication defaults	<p>The lower-case yuiop command restores the address offset to 0 and the baud rate to 19200 baud within the first few seconds after power is applied.</p> <p>yuiop command from host: yuiop↵ Response from module: None</p>
SU	Set pressure unit	<p>The SU command sets the pressure unit. The example set unit (SU) command sets the pressure unit to Torr:</p> <p>Example SU command from host: #01SUT↵ Response from module: *01 PROGM OK↵</p> <ul style="list-style-type: none">• An SUT command sets the pressure unit to Torr.• An SUM command sets the pressure unit to mbar.• An SUP command sets the pressure unit to Pascal.
RU	Read pressure unit	<p>The example read unit (RU) command causes the module to return a character string that identifies Torr as the pressure unit.</p> <p>RU command from host: #01RU↵ Example response from module: *01 TORR ↵</p> <ul style="list-style-type: none">• A "TORR " response designates Torr as the pressure unit.• An "MBAR " response designates mbar as the pressure unit.• A "PASCAL" response designates pascal as the pressure unit.
SD	Set pressure indication for optional display	<p>The SD command determines whether the optional display indicates vacuum pressure, differential pressure, or both vacuum and differential pressure. The example set display (SD) command sets the display to indicate vacuum pressure:</p> <p>Example SD command from host: #01SDA↵ Response from module: *01 PROGM OK↵</p> <ul style="list-style-type: none">• An SDA command sets the display to indicate vacuum (absolute) pressure.• An SDD command sets the display to indicate differential pressure.• An SDB command sets the display to indicate both vacuum and differential pressure. If both vacuum and differential pressure are indicated, the display indicates vacuum pressure when pressure is less than 250 Torr (333 mbar, 3.33×10^4 Pa) or differential pressure when pressure is equal to or greater than 250 Torr (333 mbar, 3.33×10^4 pa).

RD	Read vacuum pressure	<p>The example read pressure (RD) command causes the module to return a value that indicates vacuum pressure is 1.50×10^{-2}:</p> <p>Example RD command from host: #01RD↵ Example response from module: *01 1.50E-02↵</p> <p>The returned value is in the pressure unit that you've set for the module. If the returned value is not a valid representation of pressure, see page 114.</p>
RDD	Read differential pressure	<p>The example read differential pressure (RDD) command causes the module to return a value indicating a negative differential of 7.34×10^2 between vacuum and atmospheric pressures:</p> <p>Example RD command from host: #01RDD↵ Example response from module: *01-7.34E+02↵</p> <p>The returned value is in the pressure unit that you've set for the module. See page 82.</p> <p>In the response, the + or – sign that <i>precedes</i> the pressure value indicates whether the pressure differential is positive or negative.</p> <ul style="list-style-type: none">• A + sign indicates a positive pressure differential (vacuum pressure is greater than atmospheric pressure).• A – sign indicates a negative pressure differential (vacuum pressure is less than atmospheric pressure). <p>The + or – that <i>follows</i> the “E” character is the sign of the exponent. For example, a pressure value of “2.00E–2” equals 2×10^{-2} pressure units, and a pressure value of “2.00E+2” equals 2×10^2 pressure units.</p> <p>If the returned value is not a valid representation of pressure, see page 114.</p>

PC Process control relay trip points

The module may have two single-pole double-throw (normally open/normally closed) relays or three single-pole single-throw (normally open) relays. Each relay can be independently assigned to vacuum or differential pressure. Each relay has programmable activation and deactivation trip points. The trip point is a programmable value representing pressure at which the relay activates or deactivates.

- When the module is shipped from the factory, relay trip points are out of range, disabled, and will not operate.
- You must configure relays to make them operable.

The example process control (PC) command sequence causes relay 1 to activate when positive differential pressure decreases to -455 pressure units and deactivate when positive differential pressure increases to -445 pressure units:

```
Example PC command from host: #01PC1A-455␣
Response from module:        *01 PROGM OK␣

Example PC command from host: #01PC1D-445␣
Response from module:        *01 PROGM OK␣
```

The "PC1" value identifies process control relay 1.

The "A" (activation) and "D" (deactivation) pressure values determine activation and deactivation direction, as listed in Table 6-10.

Table 6-10 Activation/deactivation direction

Activation versus deactivation	Effect on relay operation
If A > D	Relay activates with increasing pressure (see Figure 6-4)
If D > A	Relay activates with decreasing pressure (see Figure 6-3)
If D = A	Software increases "D" value by minimum software defined hysteresis

Table 6-11 lists minimum hysteresis for trip point relays based on the relay assignment.

Table 6-11 Relay assignments and minimum hysteresis

Relay assignment	Hysteresis
Vacuum pressure	5%
Differential pressure	5 Torr 6.66 mbar 666.6 Pa

Figure 6-3 Default behavior of relays activating with decreasing pressure ($A > D$)

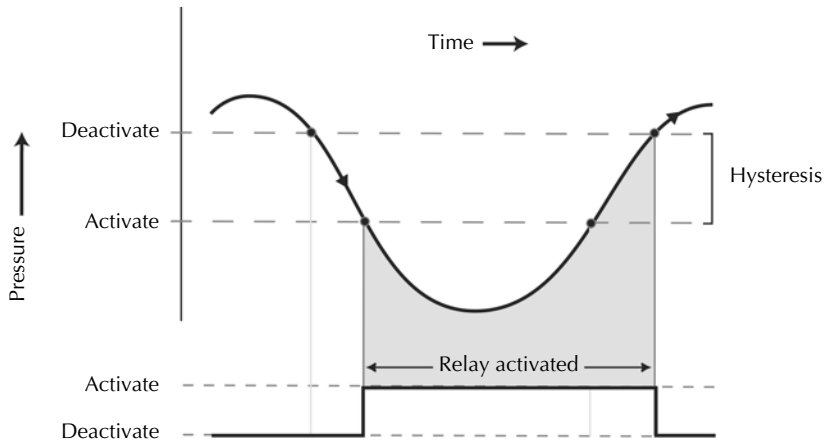
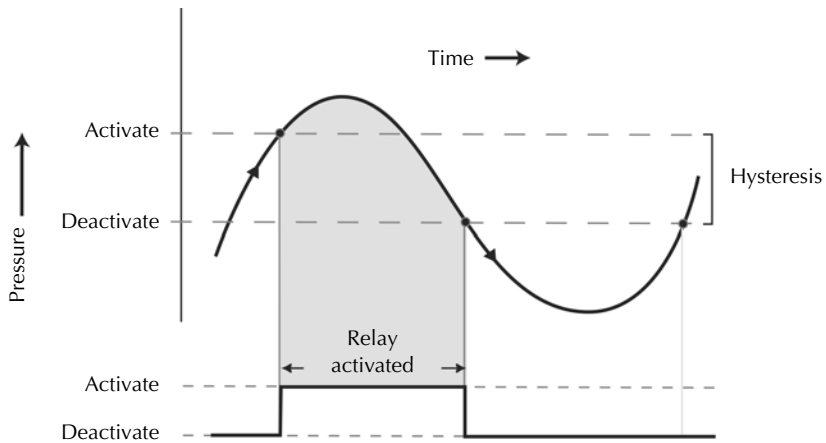

Figure 6-4 Default behavior of relays activating with increasing pressure ($D > A$)



RS-485 Operation

The plus (+) or minus (–) sign that *precedes* the pressure value is meaningful only if the relay indicates differential pressure.

If the relay is assigned to vacuum pressure, do not enter a + or – sign preceding the “A” and “D” pressure values.

- The + sign causes the relay to switch states when differential pressure is positive (vacuum pressure is greater than atmospheric pressure).
- The – sign causes the relay to switch states when differential pressure is negative (atmospheric pressure is greater than vacuum pressure).

The + or – that *follows* the “E” character is the sign of the exponent. For example, a pressure value of “2.00E–2” equals 2×10^{-2} pressure units, and a pressure value of “2.00E+2” equals 2×10^2 pressure units.

Enter the “A” and “D” pressure values in the pressure units you’ve set for the module. See page 84.

To read activation or deactivation pressure for a relay, send a PC command without the pressure value.

The example process control (PC) command sequence causes the module to return values indicating that relay 1 activates at 1.01×10^{-1} pressure units and deactivates at 2.00×10^{-1} pressure units:

Example PC command from host: #01PC1A↵

Example response from module: *01 1.01E-01↵

Example PC command from host: #01PC1D↵

Example response from module: *01 2.00E-01↵

The “PC1” value identifies relay 1.

The returned value is in the pressure unit that you’ve set for the module.

The “A” or “D” value in the PC command designates the pressure value that is being read:

- The “A” value is the indicated pressure at which the relay activates.
- The “D” value is the indicated pressure at which the relay deactivates.

The same command structure applies to both relays (PC1 and PC2) if the module has two relays, or to all three relays (PC1, PC2, and PC3) if the module has three relays.

PCG **Set trip point relay assignments**

Use the process control gauge (PCG) command to assign any relay to vacuum pressure or to differential pressure.

**WARNING**

Failure to adjust relays for the gas that is being used can cause an explosion due to overpressurization.

If relays are re-assigned, do not use the module to measure the pressure of gases other than N₂ or air without adjusting relay trip points for the process gas that will be used.

The example PCG command sequence assigns relay 1 to vacuum pressure and assigns relays 2 and 3 to differential pressure:

Example PCG command from host: #01PCGADD↵

Response from module: *01 PROGM OK↵

The 3-character string following “PCG” assigns relays in ascending numerical order.

- An “A” value assigns the specified relay to vacuum pressure.
- A “D” value assigns the specified relay to differential pressure.

In the example, “A” is the assignment for relay 1, and “D” and “D” are the assignments for relays 2 and 3.

PCE **Set or read disable/enable state of relays**

If relays have been made operable, you may send the process control disable (PCE) command to disable or enable relays.

Example PCE command from host: #01PCE011↵

Response from module: *01 PROGM OK↵

The 3-character string following “PCE” disables or enables relays in ascending numerical order.

- A value of 0 disables the specified relay (1, 2, or 3).
- A value of 1 enables the specified relay (1, 2, or 3).

In the example, “0” disables relay 1, and “1” and “1” enable relays 2 and 3.

If you disable a relay, you must re-enable it to make it operable. You must reconfigure the relay to re-enable it. See pages 84–87.

To read disabled/enabled status of relays, send a PCE command without the disable (0) or enable (1) values.

Example PCE command from host: #01PCE↵

Example response from module: *01 011 ↵

The example response means relay 1 is disabled and relays 2 and 3 are enabled.

RPCS	Read trip point relay status	<p>The read process control relay status (RPCS) command causes the module to return a numeric value that represents the status of both relays if the module has two relays or all three relays if the module has three relays.</p> <p>RPCS command from host: #01RPCS↵ Example response from module: *01 100 ↵</p> <ul style="list-style-type: none"> • A value of 1 means the specified relay (1, 2, or 3) is activated. • A value of 0 means the specified relay (1, 2, or 3) is deactivated. <p>The example response means relay 1 is activated and relays 2 and 3 are deactivated.</p>
IG	Turn Micro-Ion gauge ON or OFF	<p>When the module starts up, the Conductron sensor is ON. As pressure decreases to a level that allows the Micro-Ion gauge to operate, the sensor turns the gauge ON. In some instances, you might need to turn the Micro-Ion gauge OFF.</p> <p>The command includes the alpha characters “I” and “G” and the numeric value 0 (OFF) or 1 (ON).</p> <p>Send the ion gauge off (IG0) command to turn the Micro-Ion gauge OFF.</p> <p>IG0 command from host: #01IG0↵ Response from module: *01 PROGM OK↵</p> <p>If you send the IG0 command:</p> <ul style="list-style-type: none"> • The response to an RD (read pressure) command depends on the value in the IGM command (see page 89). • The Micro-Ion gauge remains OFF until you send an IG1 command. <p>Send the ion gauge on (IG1) command to turn the Micro-Ion gauge ON.</p> <p>IG1 command from host: #01IG1↵ Response from module: *01 PROGM OK↵</p> <p>If the Micro-Ion gauge is in manual filament mode and one filament is inoperable, you must switch to the other filament by sending the IG0 command, then sending the IG1 command (see page 92).</p>
IGS	Read Micro-Ion gauge ON/OFF status	<p>If you send the ion gauge status (IGS) command, the module returns a character string that indicates the ON/OFF status of the Micro-Ion gauge.</p> <p>IGS command from host: #01IGS↵ Example response from module: *01 1 IG ON↵</p> <ul style="list-style-type: none"> • The “1 IG ON” response means the Micro-Ion gauge is ON. • The “0 IG OFF” response means the Micro-Ion gauge is OFF.

IGM **Set or read pressure
indication when
Micro-Ion gauge is OFF**

If the Micro-Ion gauge has been turned OFF using the IG0 command and wiring terminals 3 and 5, use the IGM (ion gauge mode) command to enable or disable pressure indications from the Conductron sensor.

Example IGM command from host: #01IGM1↵

Response from module: *01 PROG OK↵

The command includes the alpha characters "I", "G", and "M" and the alphanumeric 0, 1, or "S" switch.

- The 1 switch enables pressure indications from the Conductron sensor while the Micro-Ion gauge is turned OFF.
- The 0 switch disables pressure indications from the Conductron sensor while the Micro-Ion gauge is turned OFF.

Use the "S" switch to read the pressure output configuration.

IGMS command from host: #01IGMS↵

Example response from module: *01 0 ALL↵

- The "0 ALL" character string means all pressure indications are disabled when the Micro-Ion gauge is turned OFF.
- The "0 IG" character string means pressure indications are *enabled* when the Micro-Ion gauge is turned OFF.

IOD
Set or read Micro-Ion gauge delay ON/OFF state

The ion gauge delay (IOD) command reduces the possibility that the Micro-Ion gauge filaments will burn out if the gauge turns ON at a pressure that is too high. The IOD command delays the time at which the Micro-Ion gauge turns ON with decreasing pressure.

If the IOD command is set to ON, at initial startup, the module software determines how long the Micro-Ion gauge should wait to turn ON after pressure has decreased to a point where the gauge can operate.

The command includes the alpha characters "I", "O", and "D" and the numeric value 0 (OFF) or 1 (ON).

The example IOD command sets the delay time to OFF. (The Micro-Ion gauge turns ON, without delay, at the pressure at which the gauge can operate.)

Example IOD command from host: #01IOD0↵

Response from module: *01 PROGM OK↵

- if the Micro-Ion gauge has tungsten filaments, the default setting for the IOD command is ON (1).
- If the Micro-Ion gauge has yttria-coated iridium filaments, the default setting for the IOD command is OFF (0).

If the gauge assembly is replaced, the module software automatically sets the Micro-Ion gauge delay state according to the filament material.

During the delay, outputs indicate pressure as measured by the Conductron sensor.

If you send the IOD command without the ON or OFF value, the module returns a character string that represents the Micro-Ion delay ON/OFF state.

IOD command from host: #01IOD↵

Example response from module: *01 1 ON↵

- The "1 ON" response means the Micro-Ion gauge delay is ON.
- The "0 OFF" response means the Micro-Ion gauge delay is OFF.

If the IOD command is set to ON (1), within the pressure range of 1.00×10^{-3} to 3.00×10^{-2} Torr (1.33×10^{-3} to 39.9×10^{-2} mbar, 1.33 to 3.99 Pa), the pressure output might not be within the specified accuracy of $\pm 15\%$ of reading.

Whether or not the IOD command is set to ON (1), some signal fluctuation occurs if the Micro-Ion gauge has tungsten filaments.

IDT Set or read Micro-Ion gauge delay time

Whether or not the IOD command is set to ON, you may send the ion delay time (IDT) command to add to, determine, or read the amount of time the Micro-Ion gauge waits to turn ON after pressure has decreased to a point where the gauge can operate.

The example IDT command sets the delay time to 20 seconds.

Example IDT command from host: #01IDT 20↵

Response from module: *01 PROGM OK↵

- The command includes the alpha characters “I”, “D”, and “T” and the numeric value representing the number of seconds.
- Valid values are 0 to 600 seconds.

If the IOD command is set to ON (1), the number of seconds specified in the IDT command is *added* to the time the module software has determined that the Micro-Ion gauge should wait to turn ON with decreasing pressure, as expressed in the following equation:

$$\text{Total time delay} = \text{Time}_{\text{IOD}} + \text{Time}_{\text{IDT}}$$

If the IOD command is set to OFF (0), the number of seconds specified in the IDT command is the *exact amount* of time that the Micro-Ion gauge will wait to turn ON with decreasing pressure.

If you send the IDT command without the time value, the module returns a character string that represents the Micro-Ion gauge delay time.

DGT command from host: #01IDT↵

Example response from module: *01 60 IDT↵

The example response means the delay time is set to 60 seconds. If the IOD command is set to ON (1), the response does *not* include the delay time determined by the module software.

During the delay, outputs indicate pressure as measured by the Conductron sensor.

If the gauge assembly is replaced, the module software automatically sets the Micro-Ion gauge delay time according to the filament material.

- If the replacement gauge contains tungsten filaments, the Micro-Ion gauge waits an additional 2 seconds, beyond software-defined delay time, to turn ON with decreasing pressure.
- If the replacement gauge contains yttria-coated iridium filaments, the Micro-Ion gauge turns ON, without delay, as soon as operational pressure is achieved with decreasing pressure.

SF Set Micro-Ion gauge filament mode

The Micro-Ion gauge contains two filaments, and can operate in automatic, alternating, manual or both-filament mode of operation. The both-filament mode works at low-emission only, and is factory configured.

The example set filament (SF) command sets the gauge to manual mode.

Example SF command from host: #01SFMAN↵
 Response from module: *01 PROG M OK↵

- The SFMAN command sets the gauge to manual mode (default for Micro-Ion gauge with tungsten filaments).
- The SFALT command sets the gauge to alternating mode (default for Micro-Ion gauge with yttria-coated iridium filaments).
- The SFAUTO command sets the gauge to automatic mode.
- Table 6-12 describes operation of the filaments in automatic, alternating, both, and manual modes.
- Figure 6-5, Figure 6-6, and Figure 6-7 are flow charts showing switching patterns for each mode.

Table 6-12 Micro-Ion gauge filament modes

Filament mode	Description
Manual (default for Micro-Ion gauge with tungsten filaments)	<ul style="list-style-type: none"> • Filament 1 operates each time the Micro-Ion gauge turns ON • If filament 1 is inoperable; send IG0 command to turn Micro-Ion gauge OFF, then send IG1 command to switch to filament 2 • If both filaments are inoperable, the Micro-Ion gauge turns OFF and the value in the IGM command determines whether or not module indicates pressure
Alternating (default for Micro-Ion gauge with yttria-coated iridium filaments)	<ul style="list-style-type: none"> • Operation alternates between filament 1 and filament 2 each time the Micro-Ion gauge turns ON • If one filament is inoperable, the Micro-Ion gauge operates using the other filament • If both filaments are inoperable, Micro-Ion gauge turns OFF and value in IGM command determines whether or not module indicates pressure
Automatic	<ul style="list-style-type: none"> • Filament 1 operates each time the Micro-Ion gauge turns ON • If filament 1 is inoperable, the Micro-Ion gauge switches to filament 2 • If both filaments are inoperable, the Micro-Ion gauge turns OFF and the value in IGM command determines whether or not the module indicates pressure
Both	<ul style="list-style-type: none"> • Filament 1 and filament 2 operate at the same time • If one of the filaments cannot turn ON, the Micro-Ion gauge will operate using the other filament • If both filaments are inoperable, the Micro-Ion gauge turns OFF and the value in the IGM command determines whether or not the module indicates pressure (see IGM on page 89)

Figure 6-5 Automatic filament switching flow chart

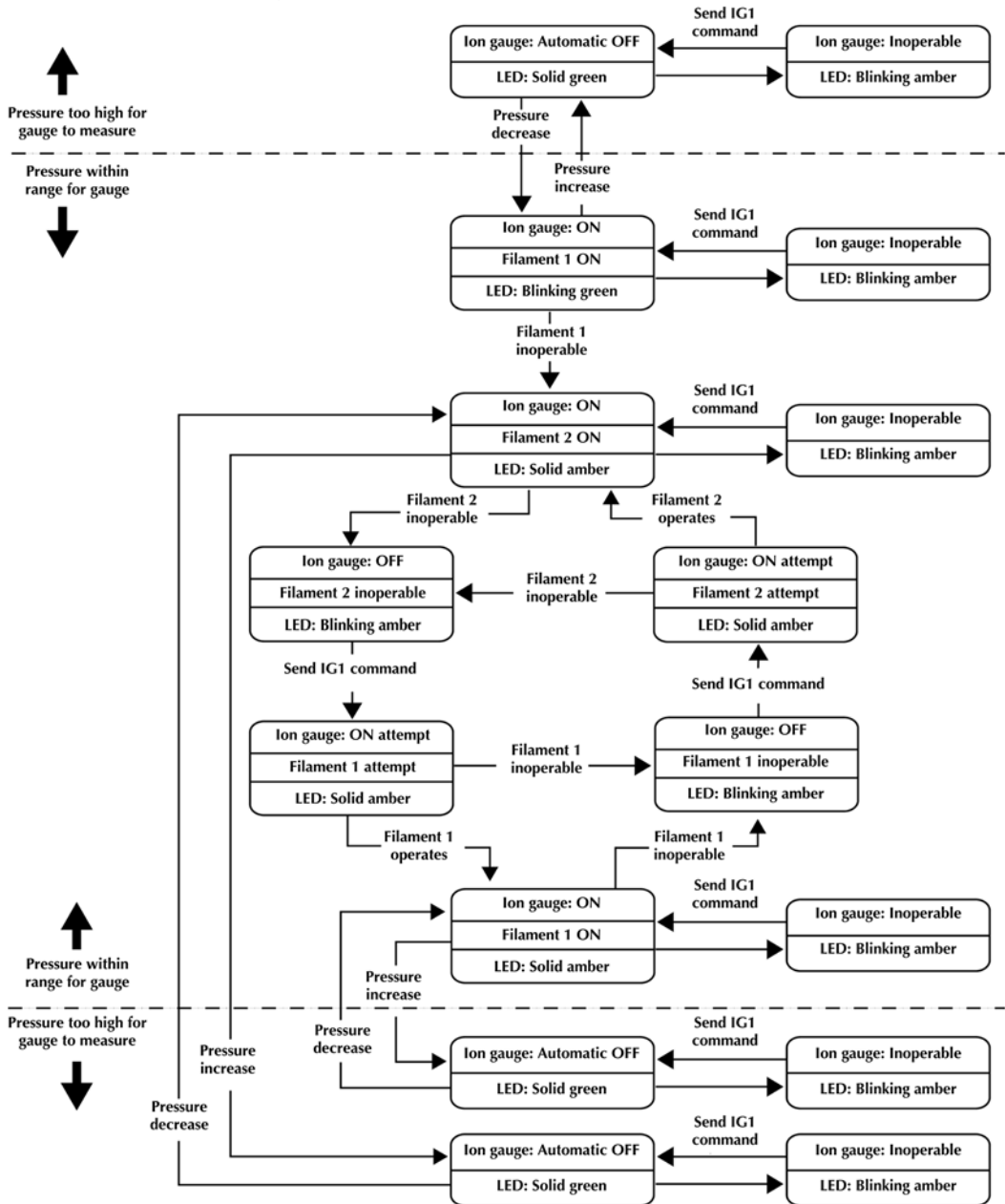

NOTE: The Micro-Ion Module is factory configured for either single-filament or both-filament operation at low emission.

RS-485 Operation

Figure 6-6 Alternating filament switching flow chart

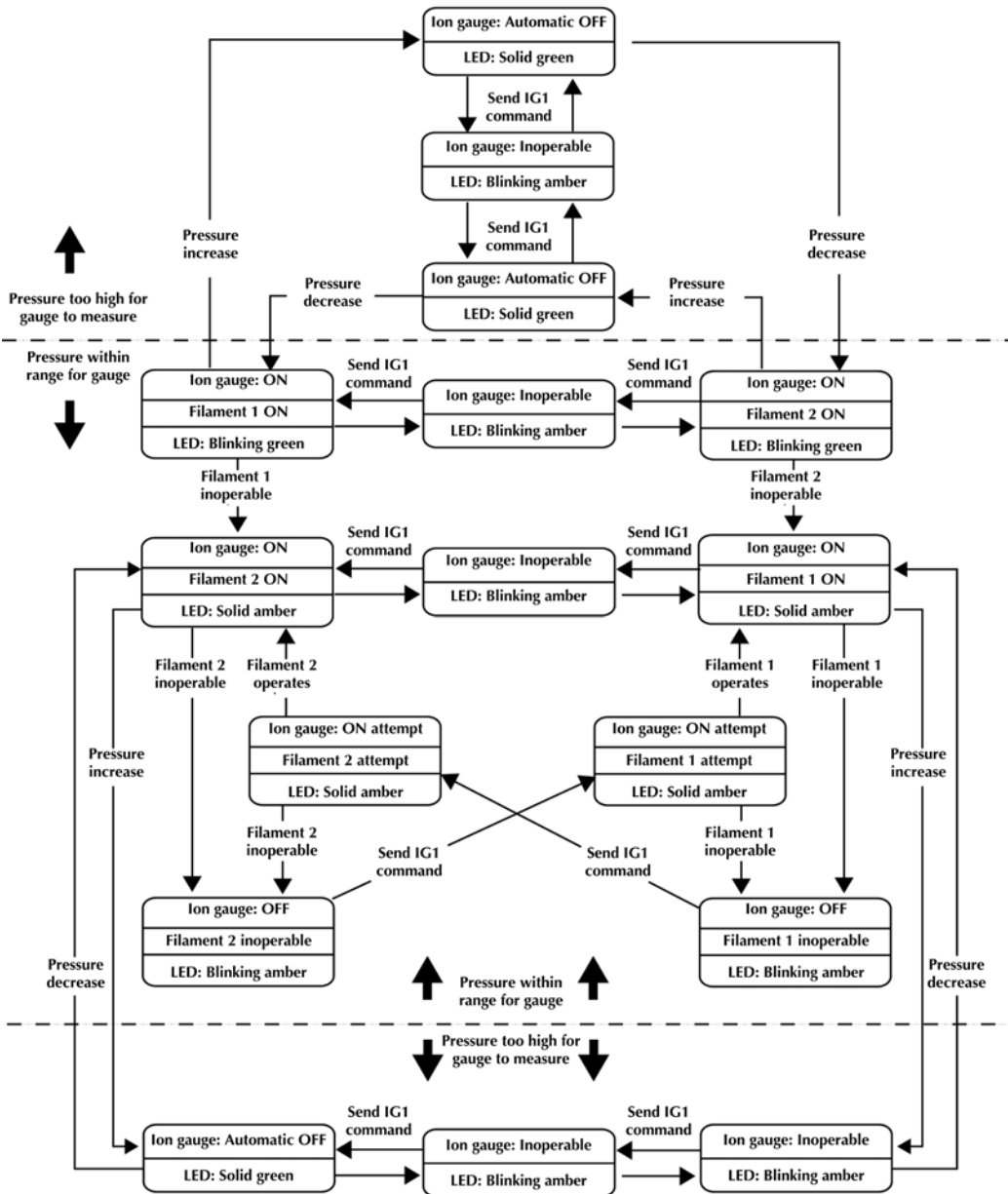

NOTE: The Micro-Ion Module is factory configured for either single-filament or both-filament operation at low emission.

RF	Read Micro-Ion gauge filament status	<p>The read filament (RF) command causes the module to return an example character string indicating filament 1 is operating.</p> <p>RF command from host: #01RF↵ Example response from module: *01 FIL SF1↵</p> <ul style="list-style-type: none"> • The "FIL SF1" response means filament 1 is operating. • The "FIL SF2" response means filament 2 is operating. • The "FIL SFB" response means both filaments (1 & 2) are operating.
DG	Degas Micro-Ion gauge	<p>Use degas gauge (DG) commands to initiate or terminate a Micro-Ion gauge degas cycle, read the degas ON/OFF state, or set the gauge degas time. The command includes the alpha characters "D" and "G" and the numeric value 0 (terminate) or 1 (initiate).</p> <p>To degas the Micro-Ion gauge, follow these steps:</p> <ol style="list-style-type: none"> 1. Turn the Micro-Ion gauge ON. (See page 89.) 2. Make sure vacuum pressure is lower than 5×10^{-5} Torr (6.66×10^{-5} mbar, 6.66×10^{-3} Pa). 3. Send the degas gauge initiate (DG1) command to initiate the Micro-Ion gauge degas cycle. The default time for gauge degas is two minutes. <p style="margin-left: 20px;">DG1 command from host: #01DG1↵ Response from module: *01 PROGM OK↵</p> 4. <i>If you wish to terminate the Micro-Ion gauge degas cycle before it is completed</i>, send the degas gauge terminate (DG0) command. <p style="margin-left: 20px;">DG0 command from host: #01DG0↵ Response from module: *01 PROGM OK↵</p>
DGS	Read Micro-Ion gauge degas status	<p>At any time, you may send the degas gauge status (DGS) command to read the Micro-Ion gauge degas state.</p> <p>DGS command from host: #01DGS↵ Example response from module: *01 1 DG ON↵</p> <ul style="list-style-type: none"> • The "1 DG ON" response means a degas cycle is in progress. • The "0 DG OFF" response means gauge degas is OFF.

DGT	Set or read Micro-Ion gauge degas time	<p>The Micro-Ion gauge degas cycle runs for two minutes unless you adjust the degas time by sending a degas gauge time (DGT) command.</p> <p>The example DGT command sets the degas time to 60 seconds.</p> <p>Example DGT command from host: #01DGT60↵ Example response from module: *01 PROGM OK↵</p> <p>Valid time values are 10 to 120 seconds.</p> <p>If you send the DGT command without the time value, the module returns a character string that represents the Micro-Ion gauge degas time.</p> <p>DGT command from host: #01DGT↵ Example response from module: *01 60 DGT↵</p> <p>The example response means the gauge degas time is set to 60 seconds.</p>
SER	Set emission current switch point	<p>The Micro-Ion gauge can operate at either of two emission current levels.</p> <ul style="list-style-type: none"> • In low-emission mode, the current level is 0.02 mA. • In high-emission mode, the current level is 4 mA. <p>As the vacuum pump removes gas from the system, the Conductron sensor measures pressure until it has decreased to a pressure at which the Micro-Ion gauge can operate. At this gauge pressure, the Conductron sensor turns the Micro-Ion gauge ON at the low emission current level.</p> <p>As pressure continues to decrease, the Micro-Ion gauge switches from low emission current to high emission current (4 mA). If pressure increases after the current level has gone from low to high, the gauge switches back to low emission current. Table 6-13 lists default, minimum, and maximum pressure values at which the gauge switches emission current levels.</p>

Table 6-13 Micro-Ion gauge emission current pressure values

Emission current setting	Default switch points	Default Filament Mode	Maximum switch points	Minimum switch points
Switch to high emission current (4 mA) with decreasing pressure	5 x 10 ⁻⁶ Torr 6.66 x 10 ⁻⁶ mbar 6.66 x 10 ⁻⁴ Pa	ALT	3 x 10 ⁻⁴ Torr 3.99 x 10 ⁻⁴ mbar 3.99 x 10 ⁻² Pa	5 x 10 ⁻⁸ Torr 6.66 x 10 ⁻⁸ mbar 6.66 x 10 ⁻⁶ Pa
Switch to low emission current with increasing pressure	1 x 10 ⁻⁵ Torr 1.33 x 10 ⁻⁵ mbar 1.33 x 10 ⁻³ Pa	SFB	6 x 10 ⁻⁴ Torr 7.99 x 10 ⁻⁴ mbar 7.99 x 10 ⁻² Pa	1 x 10 ⁻⁷ Torr 1.33 x 10 ⁻⁷ mbar 1.33 x 10 ⁻⁵ Pa

The switch back to low emission current with increasing pressure is 100% greater than the switch to high emission current with decreasing pressure, as illustrated in Figure 6-8. For example, in default mode, the current level switches from low to high emission at 5×10^{-6} Torr (6.66×10^{-6} mbar, 6.66×10^{-4} Pa), then switches back to low emission at 1×10^{-5} Torr (1.33×10^{-5} mbar, 1.33×10^{-3} Pa).

Figure 6-8 Example emission current switch points

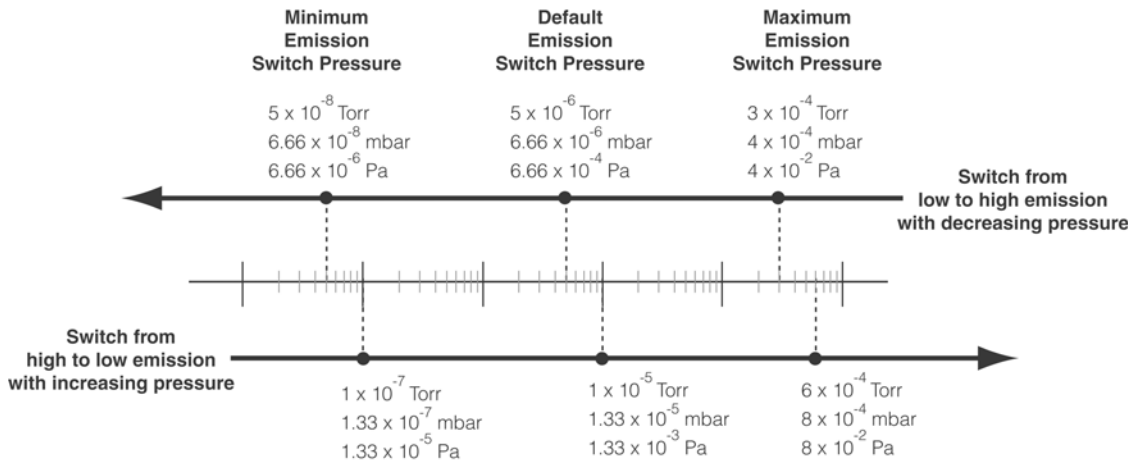

Use the set emission range (SER) command to set or read the pressure at which the Micro-Ion gauge switches from low to high emission current with decreasing pressure.

```
Example SER command from host: #01SER 1.00E-06␣
Response from module:         *01 PROG OK␣
```

The example SER command sets a value of 1×10^{-6} pressure units for the pressure at which the Micro-Ion gauge switches from low to high emission current.

To read the emission current switch point, send an SER command without the pressure value.

```
Example SER command from host: #01SER␣
Example response from module:  *01 5.00E-05␣
```

The returned value is in the pressure unit that you've set for the module. See page 82.

- RE** **Read Micro-Ion gauge emission current**
- Send the read emission (RE) command to read the Micro-Ion gauge emission current.
- RE command from host: #01RE↵
- Example response from module: *01 4.0MA EM↵
- Table 6-14 lists module responses to the RE command.

Table 6-14 Responses to RE command

Response	Description
4.0 mA EM	The Micro-Ion gauge is in high-emission mode (4.0 mA current)
0.02 mA EM	The Micro-Ion gauge is in low-emission mode (0.02 mA current)
15 mA EM	The Micro-Ion gauge degas cycle is in progress. See page 96.
0 IG OFF	The Micro-Ion gauge is OFF. See page 88.

- TS** **Calibrate module at atmospheric pressure**
- Atmospheric pressure calibration and differential pressure zero are performed using N₂ at the factory before the module is shipped. Differential pressure zero is the pressure value at which atmospheric and vacuum pressures are equal. The factory calibration sets the differential pressure zero to approximately 760 Torr (1013 mbar, 1.01 x 10⁵ Pa). The module will not operate properly unless you reset the atmospheric pressure calibration and differential pressure zero at the ambient operating pressure.
- If the atmospheric pressure calibration value is too low, the Micro-Ion gauge will not turn ON.
- Use N₂ or air to calibrate the module at atmospheric pressure. Minimum valid calibration pressure is 500 Torr (666 mbar, 6.66 x 10⁴ Pa).
- To ensure accurate calibration, make sure the differential pressure sensor is vented and open to atmosphere when you calibrate the module at atmospheric pressure.
 - Shut the pump OFF and, using N₂ or air, allow the vacuum pressure to increase until it equals atmospheric pressure.
 - Send a calibration at system pressure (TS) command.
- Example TS command from host: #01TS↵
- Example response from module: *01 PROGM OK↵
- If the module returns a message other than "PROGM OK" in response to the TS command, the atmospheric calibration has failed. See page 114 to troubleshoot the problem.

TZ **Calibrate module at vacuum pressure**

Ordinarily, the Conductron sensor turns the Micro-Ion gauge ON when pressure decreases to 2×10^{-2} Torr (2.66×10^{-2} mbar, 2.66 Pa). However, if the Conductron sensor calibration has shifted so that the Micro-Ion gauge cannot turn ON, you can recalibrate the module for vacuum pressure.

Use N₂ or air to calibrate the module at vacuum pressure. Maximum valid calibration pressure is 3.00×10^{-2} Torr (3.99×10^{-2} mbar, 3.99 Pa).

1. Turn the pump ON and, using N₂ or air, allow the vacuum chamber to decrease to the optimal calibration pressure of 1×10^{-4} Torr (1.33×10^{-4} mbar, 1.33×10^{-2} Pa) or a lower pressure.
2. Send the calibration at vacuum pressure (TZ) command.

Example TZ command from host: #01TZ↵

Example response from module: *01 PROGM OK↵

If the module returns a message other than "PROGM OK" in response to the TZ command, the vacuum pressure calibration has failed. See page 114 to troubleshoot the problem.

ATM **Set or read atmospheric pressure output**

Use the atmospheric pressure output (ATM) command to set or read the pressure value that the module will indicate each time the module senses zero differential between atmospheric and chamber pressures.

The ATM command followed by the character string "ACTUAL" sets the output to indicate actual atmospheric pressure whenever the module senses zero differential between atmospheric and chamber pressure.

Example ATM command from host: #01ATM ACTUAL↵

Example response from module: *01 PROG OK↵

The ATM command followed by a 3-digit value specifies a value that will be indicated whenever the module senses zero differential between atmospheric and chamber pressure.

Example ATM command from host: #01ATM 760↵

Example response from module: *01 PROG OK↵

The example ATM command sets outputs to indicate atmospheric pressure of 760 whenever the module senses zero differential between atmospheric and chamber pressure.

You can use the ATMS command to read the value that has been set using the ATM command.

ATMS command from host: #01ATMS↵

Example response from module: *01 650 ↵

The example response means the output will indicate a value of 650 pressure units whenever the module senses zero differential between atmospheric and chamber pressure.

The "ACTUAL" response means the output will indicate the actual atmospheric pressure whenever the module senses zero differential between atmospheric and chamber pressures.

RS **Read module status RS-485 strings**

Send the read status (RS) command to read RS-485 character strings that indicate the module operating status.

RS command from host: #01RS↵

Example response from module: *01 00 ST OK↵

The example response indicates the module is operating normally.

Table 6-15 lists module responses to the RS command. To find out if more than one status condition exists, send another RS command. Repeatedly sending the RS command causes the responses to cycle through the entire list of existing status conditions as many times as necessary while you diagnose and remedy all existing status conditions.

Table 6-15 Module status RS-485 strings

Response	Cause	Solution
00 ST OK	Module is operating normally.	No solution necessary.
01 CGBAD	Conductron sensor is inoperable.	Replace gauge assembly. See page 118.
02 DGBAD	Pressure diaphragm sensor is inoperable.	
03 OVTMP	Measured temperature > 80 ° C.	Decrease ambient temperature.
04 IGDIS	Micro-Ion gauge is disabled.	Send IGM1 command or open the switch between pins 3 and 5 on the subminiature D connector to turn the Micro-Ion gauge ON. See page 32 or 89.
05 IG HV	Micro-Ion gauge grid voltage failure.	Cycle power to module or send IG1 command to clear status response (see page 88).
06 IG EM	Micro-Ion gauge emission failure.	
07 IGFIL	One Micro-Ion gauge filament is open.	<ul style="list-style-type: none"> • If SF command is set to AUTO or ALT, operation automatically switches to the other filament. See page 88. • If SF command is set to MAN, send IG0 command, then send IG1 command to switch filaments (see page 88).
08 POWER	Power cycle has occurred, module is starting up.	No solution necessary. The “00 ST OK” string will be generated next if the module is operating properly.
09 NVRAM	Module NVRAM is invalid due to electronics failure.	Return the module to the factory. See page 119.
10 GVRAM	Micro-Ion gauge electronics failure.	Send FAC command to set values to factory defaults. See page 106. Pressure readings may be inaccurate.
11 DGCAL	Module cannot be calibrated at atmospheric pressure.	Make sure vacuum pressure = atmospheric pressure, then re-send TS command. See page 100.
12 CGCAL	Module cannot be calibrated at vacuum pressure.	Make sure vacuum pressure $\leq 1 \times 10^{-4}$ Torr (1.33×10^{-4} mbar, 1.33×10^{-2} Pa), then re-send TZ command (see page 99).
13 BGBAD	Atmospheric pressure diaphragm sensor failure.	Return the module to the factory. See page 119.

If more than one ERROR exists, the first error will respond with the first RS command; the second will respond with the second RS command; and so on until all errors are shown; then the list will repeat.

RSX **Read module status
hexadecimal bits**

Send the read status hexadecimal (RSX) command to read hexadecimal bits that indicate the module operating status.

RSX command from host: #01RSX↵

Example response from module: *01 000000A0↵

The example response indicates that ambient temperature > 80 ° C and a Micro-Ion gauge grid voltage failure has occurred.

The module returns a 32-bit hexadecimal value. Each bit stands for a specific error condition. Each bit has a value of 0, 1, 2, 3, 4, 5, 6, 7, 8, 9, A_{hex} (10), B_{hex} (11), C_{hex} (12), D_{hex} (13), E_{hex} (14), or F_{hex} (15). To clear hexadecimal status bits, cycle power to the module.

To determine the error conditions indicated by a hexadecimal value, refer to Table 6-16, Table 6-17, and Table 6-18, and follow these steps:

1. Convert the "A" to the binary value 1010. (With binary data, each digit has a value of 1 or 0).

1xxx binary = 8_{hex}

xx1x binary = 2_{hex}

2. So, the response "000000A0" can be separated into 00000080 (Micro-Ion gauge grid voltage failure) and 00000020 (ambient temperature > 80 ° C).

Bits can represent fatal errors, warnings, or information.

- A fatal error bit means the module has stopped operating. Table 6-16 lists hexadecimal fatal error bits.
- A warning bit means the module can operate but measurements may be inaccurate. Table 6-17 lists hexadecimal warning bits.
- An informational bit means the module is operating normally. Table 6-18 lists hexadecimal informational bits.

Table 6-16 Hexadecimal fatal error bits: Module has stopped operating

Fatal error bit	Cause	Solution
0 _{hex} 00000001	<ul style="list-style-type: none"> • Conductron sensor is inoperable. • Module electronics failure. 	<ul style="list-style-type: none"> • If Conductron sensor is inoperable, replace gauge assembly. See page 118. • If electronics failure, return module to factory. See page 119.
0 _{hex} 00000002		
0 _{hex} 00000004		
0 _{hex} 00000040	<ul style="list-style-type: none"> • Grid in Micro-Ion gauge is shorted. • Module electronics failure. 	<ul style="list-style-type: none"> • If Micro-Ion gauge grid is shorted or filaments are open, send IGM1 command to enable pressure readings from Conductron sensor and pressure diaphragm sensors. See page 89. • If electronics failure, return module to factory. See page 119.
0 _{hex} 00000080	<ul style="list-style-type: none"> • Micro-Ion gauge grid voltage failure. • Module electronics failure. 	
0 _{hex} 00000800	Module NVRAM is invalid during Initial startup or due to electronics failure.	Return the module to the factory. See page 119.
0 _{hex} 00200000	PRD wrong type.	Return the module to the factory. See page 119.

Table 6-17 Hexadecimal warning bits: Module can operate but measurements may be inaccurate

Warning bit	Cause	Solution
0 _{hex} 00000008	Vacuum pressure diaphragm sensor is inoperable.	Pressure readouts will indicate pressure as measured by Conductron sensor. Module will not indicate differential pressure, Micro-Ion gauge failure, or electronics failure.
0 _{hex} 00000010	Atmospheric pressure diaphragm sensor is inoperable.	
0 _{hex} 00001000	Micro-Ion gauge NVRAM is invalid.	Send FAC command to set values to factory defaults (see page 106). Pressure readings may be inaccurate.
0 _{hex} 00002000	A pressure diaphragm sensor is inoperable.	Pressure readouts will indicate pressure as measured by Conductron sensor. Module will not indicate differential pressure, Micro-Ion gauge failure, or electronics failure.
0 _{hex} 00004000	Differential pressure zero cannot be calibrated.	Make sure atmospheric pressure ± 760 Torr (1013 mbar, 1.01×10^5 Pa), then re-send TS command (see page 99).
0 _{hex} 00008000	Conductron sensor cannot be calibrated at vacuum pressure.	Make sure vacuum pressure $\leq 1 \times 10^{-4}$ Torr (1.33×10^{-4} mbar, 1.33×10^{-2} Pa), then re-send TZ command (see page 100).
0 _{hex} 00010000	Conductron sensor cannot be calibrated at atmospheric pressure.	Make sure atmospheric pressure equals vacuum pressure, then re-send TS command. See page 99.
0 _{hex} 00020000	Barometric gauge defective (temperature out of range).	Return the module to the factory. See page 119.
0 _{hex} 00040000	Barometric gauge defective (pressure out of range).	Return the module to the factory. See page 119.
0 _{hex} 00080000	No communication from the barometric gauge.	Return the module to the factory. See page 119.
0 _{hex} 00100000	Barometric gauge defective (cannot set Atmosphere calibration).	Return the module to the factory. See page 119.

Table 6-18 Hexadecimal informational bits: Module is operating normally

Response	Cause	Solution
0 _{hex} 00000000	Module is operating normally.	No solution necessary.
0 _{hex} 00000100	One Micro-Ion gauge filament is open.	<ul style="list-style-type: none"> • If SF command is set to AUTO or ALT, operation automatically switches to the other filament. See page 92. • If SF command is set to MAN, send IG0 command, then send IG1 command to switch filaments. See page 88.
0 _{hex} 00000400	Power cycle has occurred, module is starting up.	No solution necessary.
0 _{hex} 00000020	Measured temperature > 80 ° C.	Decrease ambient temperature.

RST **Reset module to power-up state**

The reset (RST) command resets the module to power-up status.

RST command from host: #01RST↵

Response from module: None

Sending the RST command has the same effect as cycling power to the module. Communication is re-enabled two seconds after you've sent the RST command.

FAC Reset values to factory defaults

Table 6-19 lists default settings for the module. After you’ve reconfigured the module, you may restore parameters to their default values by sending a factory reset (FAC) command.

FAC command from host: #01FAC↵
 Response from module: *01 PROGM OK↵
 Reset command from host: #01RST↵
 Response from module: None

Table 6-19 Factory default settings affected by FAC command

Parameter	Default Setting
Digital communication	Baud rate: 19200 baud
Vacuum calibration pressure	1×10^{-4} Torr (1.33×10^{-4} mbar, 1.33×10^{-2} Pa)
Atmospheric calibration pressure	760 Torr (1013 mbar, 1.01×10^5 Pa)
Differential pressure zero	760 Torr (1013 mbar, 1.01×10^5 Pa)
Micro-Ion gauge emission current switch point	<ul style="list-style-type: none"> • With decreasing pressure: <ul style="list-style-type: none"> 5×10^{-6} Torr 6.66×10^{-6} mbar 6.66×10^{-4} Pa • With increasing pressure: <ul style="list-style-type: none"> 1×10^{-5} Torr 1.33×10^{-5} mbar 1.33×10^{-3} Pa
Locked interface functions	OFF

VER Read firmware version

The read firmware version (VER) command causes the module to return a value that represents the internal part number and firmware version for the module. The example response indicates the internal part number is 16781 and the firmware version is 07

VER command from host: #01VER↵
 Example response from module: *01 16781-07↵

- The first five digits (preceding the dash) are the internal part number.
- The last two digits (following the dash) are the firmware version.

Chapter 7 Optional Display

7.1 Display capabilities

The optional display is a backlit, 72-dot by 48-dot matrix that can indicate vacuum pressure, differential pressure, and error conditions.

Using the RS-485 interface, you can send a set display (SD) command that enables the display to indicate vacuum (absolute) pressure when pressure is less than 250 Torr (333 mbar, 3.33×10^4 Pa) and differential pressure when pressure is equal to or greater than 250 Torr (333 mbar, 3.33×10^4 Pa). See page 82.

The display pressure range is 0.1×10^{-10} to atmosphere.

The display also indicates Torr ("TORR"), mbar ("MBAR"), or Pascal ("PA") as the unit of pressure. The "A" or "D" to the right of the pressure unit indicates vacuum (absolute) pressure ("A") or differential pressure ("D").

Vacuum pressure display

For vacuum pressure, the $X.X\pm Y$ display format includes two significant digits, a 1-digit exponent, and a \pm sign for the exponent. See Figure 7-1.

Differential pressure display

For differential pressure, the $\pm X.X\pm Y$ display format includes a \pm sign for positive or negative differential pressure, two significant digits, a 1-digit exponent, and a \pm sign for the exponent. See Figure 7-2.

Figure 7-1 Optional display indicating vacuum pressure

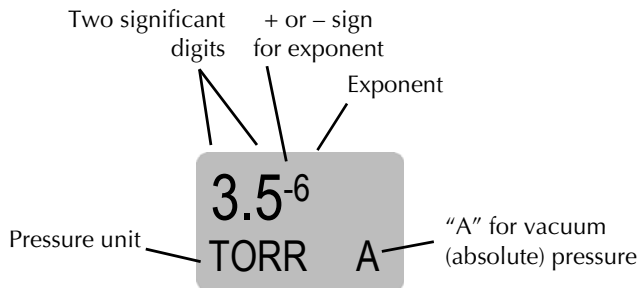
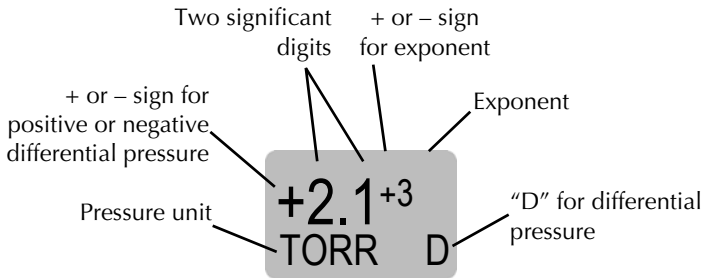

Figure 7-2 Optional display indicating differential pressure



7.2 Display resolution Pressure values in the 10^{-10} range (such as 6×10^{-10}) will appear as “0.6⁻⁹”. The resolution of the numeric display changes over the operating range of the module. See Table 7-1.

Table 7-1 Display resolution versus measured pressure

Measured pressure			Display resolution
Torr	mbar	Pa	
Less than 50	Less than 66	Less than 6.6×10^3	Two digits
50 to 100	66 to 133	6.6×10^3 to 1.33×10^4	10 pressure units
100 to 1000	133 to 1.3×10^3	13.3×10^4 to 1.33×10^5	100 pressure units

7.3 Error conditions If an error condition exists, the display indicates the condition, as illustrated in Figure 7-3.

If more than one error condition exists, the display indicates the first condition, then reverts to indicating the pressure unit, then indicates the second condition, etc. The display continues scrolling through the error indications until all conditions have been diagnosed and eliminated.

To troubleshoot error conditions indicated by the display, see Table 7-2.

Figure 7-3 Optional display indicating an error condition

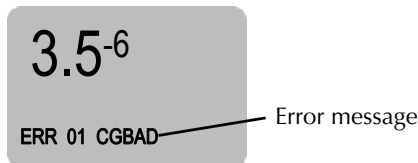

Table 7-2 Error conditions indicated by optional display

Error message	Cause	Solution
GAUGE OK	Module is in startup mode and operating normally.	No solution necessary.
ERR 01 CGBAD	Conductron sensor is inoperable.	Replace gauge assembly (see page 118).
ERR 02 DGBAD	Pressure diaphragm sensor is inoperable.	
WAR 03 OVTMP	Measured temperature > 80 ° C.	Decrease ambient temperature.
ERR 05 IG H	Micro-Ion gauge grid voltage failure.	Cycle power to module.
ERR 06 IG EM	Micro-Ion gauge emission failure.	
WAR 07 IGFIL	One Micro-Ion gauge filament is open.	<ul style="list-style-type: none"> • If filament mode is automatic or alternating, operation automatically switches to the other filament (see page 60 or page 92). • If filament mode is manual, turn Micro-Ion gauge OFF, then back ON to switch filaments (see page 58 or page 88).
WAR 09 NVRAM	Module NVRAM is invalid due to electronics failure.	Return module to factory (see page 119).
WAR 10 GVRAM	Micro-Ion gauge electronics failure.	Set programmable values to factory defaults (see page 67 or page 106). Pressure readings may be inaccurate.
WAR 11 DGCAL	Module cannot be calibrated at atmospheric pressure.	Make sure vacuum pressure = atmospheric pressure, then re-calibrate at atmospheric pressure (see page 35, page 65, or page 99).
WAR 12 CGCAL	Module cannot be calibrated at vacuum pressure.	Make sure vacuum pressure $\leq 1 \times 10^{-4}$ Torr (1.33×10^{-4} mbar, 1.33×10^{-2} Pa), then re-calibrate at vacuum pressure (see page 35, page 65, or page 100).
ERR 13 BGBAD	Atmospheric pressure diaphragm sensor failure.	Return module to factory (see page 118).

Chapter 8 Maintenance

8.1 Customer service

For customer service:

- Phone 1-303-652-4400 or 1-800-776-6543, 8 AM to 5 PM Mountain Time Zone weekdays, excluding holidays within the USA.
- Phone 1-800-367-GUTS (1-800-367-4887) 24 hours per day, seven days per week within the USA.
- Email co-csr@brooks.com
- For Global Customer Support, go to www.brooks.com and click on *Services* to locate the Brooks Automation office nearest you.

Damage requiring service

Shut off power to the module and refer servicing to qualified service personnel under the following conditions:

- The product has been exposed to rain or water.
- The product does not operate normally, even if you have followed the operation instructions. Operate only those controls that are covered in the instruction manual.
- The product has been dropped or the module enclosure has been damaged.
- The product exhibits a distinct change in performance.

If the module requires repair:

- See page 119
- Phone **1-303-652-4400** or **1-800-776-6543** within the USA, or
- email co-csr@brooks.com.

8.2 Troubleshooting

If any of the conditions described above have occurred, troubleshooting is required to determine the repairs that are necessary.

Precautions

Because the module contains static-sensitive electronic parts, follow these precautions while troubleshooting:

- Use a grounded, conductive work surface. Wear a high impedance ground strap for personal protection.
- Do not operate the module with static sensitive devices or other components removed from the product.
- Do not handle static sensitive devices more than absolutely necessary, and only when wearing a ground strap.
- Rely on voltage measurements for troubleshooting module circuitry. Do not use an ohmmeter.
- Use a grounded, electrostatic discharge safe soldering iron.

 **WARNING**

Substitution or modifying parts can result in severe product damage or personal injury due to electrical shock or fire.

- Install only those replacement parts that are specified by Granville–Phillips.
- Do not install substitute parts or perform any unauthorized modification to the module.
- Do not use the module if unauthorized modifications have been made.

 **WARNING**

Failure to perform a safety check after the module has been repaired can result in severe property damage or personal injury due to electrical shock or fire.

If the module has been repaired, before putting it back into operation, make sure qualified service personnel perform a safety check.

Symptoms, causes, and solutions

Table 8-1 on page 113 lists failure symptoms, causes, and solutions indicated by something other than an RS-485 error message from the module.

Table 8-1 Failure symptoms, causes, and solutions

Symptom	Possible causes	Solution
Analog output voltage = 0 V	<ul style="list-style-type: none"> The power supply cable connected to the DB-15 connector is missing 24 Vdc or is improperly connected. The DeviceNet power supply cable is missing or improperly connected. The Analog output is not responding correctly. 	<ul style="list-style-type: none"> Repair or replace power supply cable (see page 20).
Pressure reading is too high.	<ul style="list-style-type: none"> Conductance in connection to vacuum chamber is inadequate. Plumbing to module leaks or is contaminated. Chamber pressure is too high due to leak, contamination, or pump failure. Power supply or output cable is improperly connected or faulty. 	<ul style="list-style-type: none"> If conductance is inadequate, reconnect Conductron sensor port to a larger conductance port on the vacuum chamber, or install larger conductance plumbing. If plumbing leaks or is contaminated, clean, repair or replace plumbing. If pump failed, repair or replace it. If cable is improperly connected or faulty, repair or replace cable (see page 20).
Pressure reading is inaccurate.	<ul style="list-style-type: none"> Micro-Ion gauge is contaminated. Micro-Ion gauge, Conductron sensor, or vacuum pressure diaphragm sensor is damaged (for example, by reactive gas) or contaminated. Temperature or mechanical vibration is extreme. 	<ul style="list-style-type: none"> If Micro-Ion gauge is contaminated, degas the gauge (see page 33, page 62, or page 96). If Micro-Ion gauge, Conductron sensor, or vacuum pressure diaphragm sensor is contaminated, replace gauge assembly (see page 118). If temperature or vibration is extreme, relocate module or eliminate source of heat or vibration.
Indicated pressure is different than pressure indications from other measurement devices.	<ul style="list-style-type: none"> Conductron sensor is defective. Micro-Ion gauge is defective 	Replace gauge assembly (see page 118).
LED status indicator is solid amber.	A Micro-Ion gauge filament is inoperable.	If possible, switch to the other filament (see page 60 and page 92).
LED status indicator is blinking amber.	Both Micro-Ion gauge filaments are inoperable.	Return module to factory (see page 119).
<ul style="list-style-type: none"> Relay will not activate. Output voltage is > 10 V. 	<ul style="list-style-type: none"> A circuit board is faulty. Conductron sensing wire is open. 	Return module to factory (see page 119).

8.3 RS-485 error responses Table 8-2 lists error responses that the module returns if you enter a command improperly or if the module non-volatile memory (NOVRAM) cannot process a command.

Table 8-2 Troubleshooting RS-485 error responses

Response	Possible causes	Solution
RANGE ER	<ol style="list-style-type: none"> 1. Pressure value in TS calibration command is outside valid limits. 2. Pressure value in TZ calibration command is outside valid limits. 3. Pressure value in ATM set command is outside valid limits. 4. Ion gauge on-delay time (IDT) is out of range. 5. Degas duration (DGT) is out of range. 6. Emission current switch point is out of range. 7. Relay trip point is out of range (ABS). 8. Relay trip point is out of range (DIFF). 	<ol style="list-style-type: none"> 1. Make sure atmospheric pressure is > 500 Torr (666 mbar, 6.66×10^4 Pa). See page 99. 2. Make sure vacuum pressure < 3.00×10^{-2} Torr (3.99×10^{-2} mbar, 3.99 Pa). See page 100. 3. Make sure the setting is reasonable (250-1000 Torr). 4. Make sure the ion gauge delay time is between 0 and 600 seconds. 5. Make sure the degas duration setting is between 10 and 120 seconds. 6. Make sure current switch point is set correctly. See SER on page 97. 7. Make sure the trip point is between 1E-10 and 1000 Torr, and hysteresis is between 5 and 10,000%. 8. Make sure the trip point is between -800 and +300 Torr, and hysteresis is between 5 and 800 Torr.
SYNTAX ER	<ul style="list-style-type: none"> • Command was improperly entered. • Module does not recognize command syntax. • UNL command was sent when software functions were already unlocked. 	<ul style="list-style-type: none"> • Re-enter command using proper character string (see page 77).
9.99E+09	<ul style="list-style-type: none"> • Module cannot indicate a valid pressure value. • IG0 command has been sent. 	<ul style="list-style-type: none"> • Send RS or RSX command to determine module status (see page 101). • If necessary, replace the gauge assembly. • If IG0 command has been sent, send IG1 command (see page 88).
LOCKED	Interface function is locked.	<ul style="list-style-type: none"> • Send TLU or UNL command to unlock interface function (see page 80).
INVALID	<ul style="list-style-type: none"> • IG1 command sent while IG ON I/O line not asserted. • Micro-Ion gauge or Conductron sensor is defective. • Vacuum pressure is too high for gauge degas. 	<ul style="list-style-type: none"> • Assert the IG ON I/O line or disconnect from ground. • If the Micro-Ion gauge or Conductron sensor is defective, replace the gauge assembly. • Decrease the pressure to < 5×10^{-5} Torr. See DG on page 96.

8.4 RS-485 status strings and hexadecimal bits

Send the read status (RS) command to read RS-485 character strings that indicate the module operating status.

RS command from host: #01RS↵

Example response from module: *01 00 ST OK↵

Send the read status hexadecimal (RSX) command to read hexadecimal bits that indicate the module operating status.

RSX command from host: #01RSX↵

Example response from module: *01 000000A0↵

For detailed information about status strings and hexadecimal bits, see pages 101–105.

8.5 DeviceNet error codes

You may use DeviceNet explicit messages or polled I/O to find out if an alarm or warning has been reported. To select polled I/O or explicit messages, see pages 44 - 46.

Using polled I/O

An alarm or warning is indicated by the status byte in the input assembly, instance 2 or instance 5. An alarm is bit weight 1, and a warning is bit weight 5, as listed in Table 8-3.

Table 8-3 Module alarm and warning status for polled I/O

Instance	BYTE data: One byte format							
2 or 5	Bit 7 0	Bit 6 0	Bit 5 Warning	Bit 4 0	Bit 3 0	Bit 2 0	Bit 1 Alarm	Bit 0 0

Using explicit messages

Alarms, warnings, and status messages are available from the objects listed in Table 8-4.

For detailed information about alarms, warnings, and status messages, see pages 68–72.

Table 8-4 DeviceNet explicit messages indicating alarms, warning, or status

Object	Service	Class	Instance	Attribute
Identity object	0E _{hex}	1	1	5
Device supervisor object	0E _{hex}	30 _{hex}	1	0C _{hex}
Analog sensor object, instance 1, Conductron sensor	0E _{hex}	31 _{hex}	1	5
Analog sensor object, instance 1, Conductron sensor	0E _{hex}	31 _{hex}	1	7
Analog sensor object, instance 2, Micro-Ion gauge	0E _{hex}	31 _{hex}	2	5
Analog sensor object, instance 2, Micro-Ion gauge	0E _{hex}	31 _{hex}	2	7
Analog sensor object, instance 2, Micro-Ion gauge	0E _{hex}	31 _{hex}	2	94

Table 8-4 DeviceNet explicit messages indicating alarms, warning, or status

Analog sensor object, instance 2, Micro-Ion gauge	0E _{hex}	31 _{hex}	2	95
Analog sensor object, instance 2, Micro-Ion gauge	0E _{hex}	31 _{hex}	2	96
Analog sensor object, instance 3, differential pressure	0E _{hex}	31 _{hex}	3	5
Analog sensor object, instance 3, differential pressure	0E _{hex}	31 _{hex}	3	7

8.6 Overpressure shutdown

To prevent damage, the module uses the Conductron sensor as an overpressure sensor for Micro-Ion gauge shutdown. The Micro-Ion gauge shuts OFF at 3×10^{-2} Torr (3.99×10^{-2} mbar, 3.99 Pa).

You cannot adjust the overpressure shutdown value.

8.7 Micro-Ion gauge continuity test

If a problem with pressure measurement is traced to the module, the Micro-Ion gauge can be tested with an ohmmeter. This test can detect open filaments or shorts between gauge elements, but may not detect inaccurate pressure measurement associated with vacuum leaks or adsorbed gases within the gauge.

The gauge may be left on the system for the test. The electronics assembly will be removed to gain access to the pins on the gauge.

1. Turn OFF power and disconnect all electrical connections to the Micro-Ion ATM module.
2. Unscrew the four captive Phillips-head screws until they disengage from the end plate of the gauge assembly. See Figure 8-1.
3. *Carefully* unplug the electronics assembly from the gauge assembly.

Figure 8-1 Removing Micro-Ion ATM gauge assembly

1. Turn OFF power and disconnect all electrical connections to module.
 2. Unscrew the captive Phillips-head screws until they disengage from end plate of gauge assembly.
 3. Carefully unplug gauge assembly from electronics assembly.
- 

Figure 8-2 Micro-Ion gauge pins

Pin	Description
1	Filament 2
2	Filament Common
3	Filament 1
4	Grid
5	Collector
6	Grid

4. Use a digital multimeter to measure the resistance between pins 2 and 3 (the filament pins), and between pins 1 and 2. See Figure 8-2. The readings should be 0.2Ω .
5. Measure the resistance of filament pins 1, 2, or 3 to any of pins 4, 5, or 6, or the gauge case. The reading should be $> 100 M\Omega$.

6. Measure the resistance between pins 4 and 6 (the grid pins). The reading should be $< 0.1 \Omega$.
7. Measure the resistance of the grid pins to any of pins 1, 2, 3, or 5, or to the gauge case. The reading should be $> 100 M\Omega$.
8. Measure the resistance of pin 5 (the collector pin) to the gauge case. The reading should be $> 100 M\Omega$.
9. If any of the tests result in different readings than listed above, Contact Granville-Phillips customer service to order a replacement gauge.

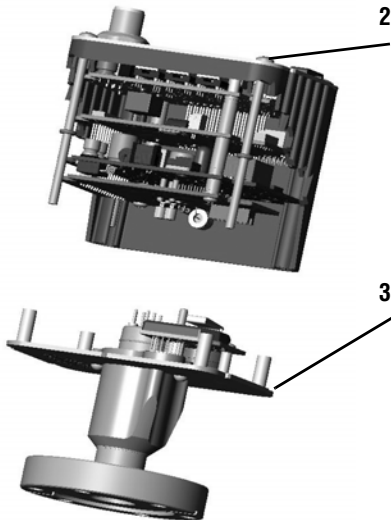
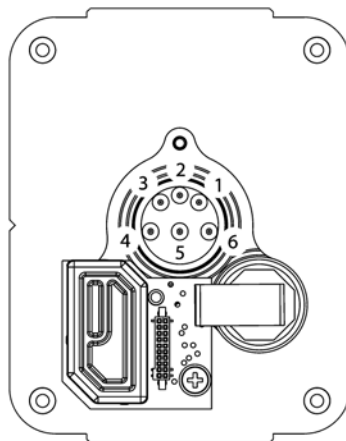
Table 8-5 Test resistance values

Pins	Normal values
1 to 2 or 2 to 3	$< 0.2 \Omega$
1, 2 or 3 to pins 4, 5, or 6	$> 100 M\Omega$
4 to 6	$< 0.1 \Omega$
4 or 6 to pins 1, 2, 3, or 5	$> 100 M\Omega$
pin 5 to case	$> 100 M\Omega$

8.8 Replacing the gauge assembly

Do not plug in or unplug any connectors with power applied to the module. Disconnect power from the module before replacing the gauge assembly.

1. Turn OFF power and disconnect all electrical connections to the Micro-Ion ATM module.
2. Disconnect the module from the vacuum chamber.
3. Unscrew the four captive Phillips-head screws until they disengage from the end plate of the gauge assembly. See Figure 8-1.
4. *Carefully* unplug the electronics assembly from the gauge assembly.
5. Insert the new gauge assembly into the electronics assembly by gently inserting the gauge pins into the socket on the circuit board. Examine the gauge pin arrangement to make sure the replacement gauge assembly and electronics assembly are aligned.
6. Tighten the four Phillips-head screws.
7. Install the module on the vacuum chamber.
8. Calibrate the module at atmospheric pressure (see page 35, page 65, or page 99).

8.9 Returning a Micro-Ion module for service

If the module must be returned for service, request a Return Authorization (RA) from Brooks Automation / Granville-Phillips. Do not return products without first obtaining an RA. In some cases a hazardous materials document may be required. The Brooks Automation / Granville-Phillips Customer Service Representative will advise you if the hazardous materials document is required.

When returning equipment to Brooks Automation / Granville-Phillips, be sure to package the products to prevent shipping damage. Circuit boards and modules separated from the controller chassis must be handled using proper anti-static protection methods and must be packaged in anti-static packaging. Brooks Automation / Granville-Phillips will supply return packaging materials at no charge upon request. Shipping damage on returned products as a result of inadequate packaging is the Buyer's responsibility. *Before you return the module*, obtain an RA number by contacting Granville-Phillips customer service:

- Phone **1-303-652-4400** or **1-800-776-6543** within the USA.
- Phone **1-800-367-4887** 24 hours per day, seven days per week within the USA.
- Email co-csr@brooks.com
- For Global Customer Support, go to www.brooks.com and click on *Services* to locate the Brooks Automation office nearest you.

Appendix A Specifications & Compliance

Pressure Measurement Specifications

Absolute Pressure for N₂ or Air	Atmospheric value is based on calibration at time of use. Measurements will change with different gases and mixtures.	
<i>Absolute Pressure Range</i>	Torr	1 x 10 ⁻⁹ to atmosphere
	mbar	1.33 x 10 ⁻⁹ to atmosphere
	Pascal	1.33 x 10 ⁻⁷ to atmosphere
<i>Accuracy for N₂ or Air</i>	Accuracy (the difference between the gauge reading and a calibrated reference standard) is determined statistically and includes the combined performance of the gauge, sensors, and electronics.	
	1 x 10 ⁻⁸ Torr to 100 mTorr	±15% of reading
	1.33 x 10 ⁻⁸ to 0.133 mbar	±15% of reading
	1.33 x 10 ⁻⁶ to 13.3 Pa	±15% of reading
	100 mTorr to 150 Torr	±10% of reading
	0.133 to 200 mbar	±10% of reading
	13.3 to 2.00 x 10 ⁴ Pa	±10% of reading
	150 to 1,000 Torr	±2.5% of reading
	200 to 1,333 mbar	±2.5% of reading
	2.00 x 10 ⁴ to 1.33 x 10 ⁵ Pa	±2.5% of reading
<i>Repeatability</i>	Repeatability refers to the ability of the same module to read the same pressure at different times.	
	1 x 10 ⁻⁸ Torr to 100 mTorr	±5% of reading
	1.33 x 10 ⁻⁸ to 0.133 mbar	±5% of reading
	1.33 x 10 ⁻⁶ to 13.3 Pa	±5% of reading
	100 mTorr to 150 Torr	±2.5% of reading
	0.133 to 200 mbar	±2.5% of reading
	13.3 to 2.00 x 10 ⁴ Pa	±2.5% of reading
	150 to 1,000 Torr	±1.0% of reading
	200 to 1,333 mbar	±1.0% of reading
	2.00 x 10 ⁴ to 1.33 x 10 ⁵ Pa	±1.0% of reading

X-ray Limit

X-ray limit is the absolute lowest indication from the gauge. It is not possible to make repeatable measurements near the x-ray limit.

Torr	$< 3 \times 10^{-10}$
mbar	$< 4 \times 10^{-10}$
Pascal	$< 4 \times 10^{-8}$

Differential Pressure

Differential Pressure Range

At room temperature:

Torr	-750 to +250
mbar	-999 to +333
kPa	-99.9 to +33.3

Accuracy

$\pm(2.5 \text{ Torr} + 2.5\% \text{ of reading})$
 $\pm(3.3 \text{ mbar} + 2.5\% \text{ of reading})$
 $\pm(0.33 \text{ kPa} + 2.5\% \text{ of reading})$

Response Time

< 25 msec

Temperature Specifications

Operating Temperature

10 to 40 °C (50 to 104 ° F), non-condensing

Storage Temperature

-40 to +70 °C (-40 to +158 ° F)

Bakeout Temperature

105 ° C (221 °F) maximum with electronics removed

Outputs and Indicators

Available Output Options	The module has one analog output, one RS-485 output, and one DeviceNet output. The module may also have an optional display.
Analog Outputs	
<i>Vacuum Pressure</i>	Logarithmic, 0.5 to 7.0 Vdc, 0.5 volt per decade
<i>Differential Pressure</i>	Linear, 1.0 to 5.0 Vdc, -750 to +250 Torr (-1000 to +333 mbar, -100 to +33 kPa)
Digital DeviceNet Output	
<i>Messaging</i>	Polled I/O and explicit
<i>Communications Format</i>	BOOL, BYTE, STRUCT, SSTRING, REAL, INT, UINT, USINT, EPATH, and WORD data
<i>Data Rates</i>	125, 250, or 500 kbaud, switch selectable
<i>Address</i>	0-63, selected by using data rate switch
<i>I/O Slave Messaging</i>	Polling, COS, cyclic
<i>NET Status LED Indicator</i>	The NET status LED lights up to indicate if the DeviceNet network has power and is functioning properly.
<i>MOD Status LED Indicator</i>	The MOD status LED lights up to indicate if the module has power or is functioning properly.
Digital RS-485 Output	
<i>Interface</i>	RS-485 two-wire, half-duplex
<i>Communications Format</i>	ASCII format, eight data bits, no parity, one stop bit
<i>Baud Rates</i>	1200, 2400, 4800, 9600, 19200 (default), or 38400 baud
<i>Address</i>	0 to 63, selected by using address switch and RS-485 command
LED Status Indicator	The status indicator illuminates to indicate the Micro-Ion sensor status: LED is solid green - indicates power is ON and the Micro-Ion sensor is OFF LED blinks green - indicates that the Micro-Ion sensor is ON LED is solid amber - indicates the Micro-Ion sensor is ON but one filament is inoperable LED blinks amber - indicates the Micro-Ion sensor is ON but both filaments are inoperable

Optional Display

Backlit, 72-dot by 48-dot matrix can indicate vacuum pressure, differential pressure, and error conditions.

RS-485 interface enables display to indicate vacuum (absolute) pressure when pressure is < 250 Torr (333 mbar, 3.33×10^4 Pa) and differential pressure when pressure \geq 250 Torr (333 mbar, 3.33×10^4 Pa).

Pressure Range

0.1×10^{-10} to atmosphere

Display Resolution

The resolution of the numeric display changes over the operating range of the module.

Pressure values in the 10^{-10} range (such as 6×10^{-10}) will appear as "0.6⁻⁹".

Pressure Units

Display indicates Torr ("TORR"), mbar ("MBAR"), or Pascal ("PA") as the unit of pressure.

The "A" or "D" to the right of the pressure unit indicates vacuum (absolute) pressure ("A") or differential pressure ("D").

Vacuum Pressure Display

For vacuum pressure, X.X \pm Y display format includes two significant digits, a 1-digit exponent, and a \pm sign for the exponent.

"A" to the right of the pressure unit indicates vacuum (absolute) pressure.

Differential Pressure Display

For differential pressure, \pm X.X \pm Y display format includes a \pm sign for positive or negative differential pressure, two significant digits, a 1-digit exponent, and a \pm sign for the exponent.

"D" to the right of the pressure unit indicates differential pressure.

Error Conditions

If an error condition exists, the display indicates the condition.

If more than one error condition exists, the display indicates the first condition, then reverts to indicating the pressure unit, then indicates the second condition, etc. The display continues scrolling through the error indications until all conditions have been diagnosed and eliminated.

Optional Trip Point Relays

Relay Type	Two single-pole double-throw (normally open/normally closed) or three single-pole single-throw (normally open) relays. Each relay can be independently assigned to vacuum or differential pressure.
Relay Contact Ratings	Relay contacts are silver alloy-gold clad, rated for 1 A at 30 Vdc. The relays can handle resistive loads.
<i>Maximum</i>	1 A at 30 Vdc, resistive load
<i>Minimum</i>	5 mA at 5 Vdc, resistive load
Relays Assigned to Vacuum Pressure	
<i>Minimum Hysteresis</i>	5%
<i>Range</i>	1.0 x 10 ⁻⁹ to 1000 Torr 1.33 x 10 ⁻⁹ to 1333 mbar 1.33 x 10 ⁻⁷ to 1.33 x 10 ⁵ Pa
Relays Assigned to Differential Pressure	
<i>Minimum Hysteresis</i>	5% vacuum pressure 5 Torr (6.66 mbar, 666.6 Pa) differential pressure
<i>Range</i>	-500 to +250 Torr -666 to +333 mbar -6.66 x 10 ⁻⁴ to +3.33 x 10 ⁴ Pa
Default Activation Pressure	Default activation pressures are out of range and require configuration.

Micro-Ion Sensor

Emission Current	0.02 mA, 0.1 mA, or 4 mA, automatically set Use RS-485 commands to set switch point for high and low emission currents.
Default Control Settings	
<i>Gauge ON</i>	2 x 10 ⁻² Torr with decreasing pressure 2.66 x 10 ⁻² mbar with decreasing pressure 2.66 Pa with decreasing pressure
<i>Gauge OFF</i>	3 x 10 ⁻² Torr with increasing pressure 3.99 x 10 ⁻² mbar with increasing pressure 3.99 Pa with increasing pressure
<i>Switch to High Emission</i>	5 x 10 ⁻⁶ Torr with decreasing pressure 6.66 x 10 ⁻⁶ mbar with decreasing pressure 6.66 x 10 ⁻⁴ Pa with decreasing pressure
<i>Switch to Low Emission</i>	1 x 10 ⁻⁵ Torr with increasing pressure 1.33 x 10 ⁻⁵ mbar with increasing pressure 1.33 x 10 ⁻³ Pa with increasing pressure
<i>Gauge Degas</i>	Electron bombardment; 3 W for default time of 1 minute per filament. Degas time is programmable from 10 to 120 seconds using the RS-485 interface.
Filaments	Solid tungsten or yttria-coated iridium
Filament Operation Mode	
<i>Alternating Mode</i>	Module alternates between filaments with each activation of the gauge.
<i>Automatic Mode</i>	Filament 1 is used until it becomes inoperable, then the module automatically switches to filament 2.
<i>Manual Mode</i>	Filament 1 is used until it becomes inoperable, then manual intervention is required to activate filament 2.
<i>Both Mode</i>	Both filament 1 and filament 2 are ON until one of the filaments becomes inoperable, then the operable filament continues to function. NOTES: During low-emission operation in the Both mode, (the default for yttria-coated iridium filaments) both filaments are operating (ON). During high-emission operation of yttria-coated filaments, the default is "alternating mode; during high-emission operation with Tungsten filaments, the default mode is "manual" mode.

Conductron Heat-loss Sensor

Sensing Wires	Gold-plated tungsten
----------------------	----------------------

Electrical Connectors

I/O Connector	15-pin subminiature D male connector has terminals for module power supply, analog output, RS-485 output, relays, Micro-Ion gauge ON/OFF, and Micro-Ion gauge degas.
<i>Cable Types</i>	For cable that connects to the 15-pin I/O connector, install shielded cable with aluminum jacket and a tinned copper braid with a minimum of 65% coverage. On the module end of the cable, install a metal housing, so the shield is continuous from the cable to the gauge housing. Do not ground the shield at the system end.
<i>Module Power Supply</i>	Power supply requirement is 24 Vdc +10% to -15%, 1.0 A, 22 W nominal. Maximum inrush current is 2 A, 48 W for 0.5 seconds. Power supply must supply at least 2 A, (48 W) current for at least 0.5 seconds during Micro-Ion sensor startup. The Micro-Ion sensor will not activate, and an emission error will occur if insufficient power is supplied during Micro-Ion sensor activation. Power inputs are reverse-bias protected.
DeviceNet Micro Connector	DeviceNet 5-pin micro connector has terminals for a standard micro 5-pin female cable connection.
<i>Cable Types</i>	Install raw cable that has a braided shield over the aluminum foil-shielded signal and power wires. On the module end of the cable, install a metal housing, so the shield is continuous from the cable to the gauge housing. Do not ground the shield at the receiver or output device.
<i>DeviceNet Power Supply</i>	The module will use terminals 2 (Vdc return) and 3 (24 Vdc) on the 5-pin DeviceNet micro connector for the network power supply. The DeviceNet interface requires 24 Vdc (11 to 26.4) at 0.2 A maximum. Maximum inrush current is 0.25 A. Power inputs are reverse-bias protected.
Compliance	Compliance with CE Mark requires metal connector housings and cable with a braided shield. The braided shield must be connected only to the outer shell of the 15-pin subminiature D connector or 5-pin DeviceNet micro connector on the module, not to the receiver or output device.
<i>EMC</i>	EN61326-1
<i>Product Safety</i>	EN61010-1
<i>IP Rating</i>	IP20
<i>Environmental</i>	RoHS Compliant

Physical specifications

Weight	728.5 g (25.7 oz.) with 2.75-inch ConFlat flange
Case Material	Powder-coated extruded aluminum
Materials Exposed to Vacuum	304 stainless steel, tantalum, tungsten, yttria-coated iridium, alumina, CuAg eutectic, Kovar, gold-plated and nickel-plated Kovar, borosilicate glass
Dimensions	

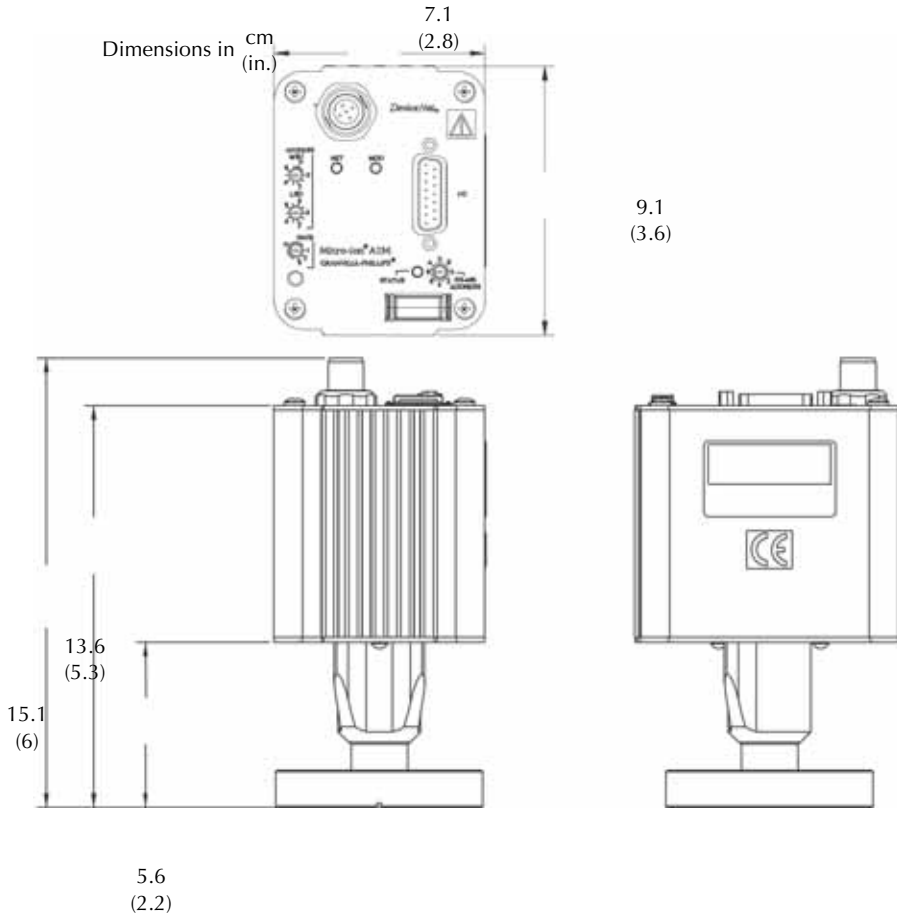

Appendix B Messaging Summary

B.1 Polled I/O messaging summary

Input I/O (to master)

Instance	Master data	Device data	Data type	Description	Type
1	None	00 00	UINT	UINT vacuum pressure	Open
2	None	00 00 00	STRUCT	BYTE exception status UINT vacuum pressure	Open
3	None	00 00 00 00	STRUCT	BYTE exception status BYTE trip point status UINT vacuum pressure	Open
4	None	00 00 00 00	REAL	REAL vacuum pressure	Open
5	None	00 00 00 00 00	STRUCT	BYTE exception status REAL vacuum pressure	Open
6	None	00 00 00 00 00 00	STRUCT	BYTE exception status BYTE trip point status REAL vacuum pressure	Open
0F _{hex}	None	00 00 00 00 00 00 00 00	UINT INT	UINT vacuum pressure INT differential pressure Placeholders	Open
10 _{hex}	None	00 00 00 00 00 00 00 00 00	BYTE UINT INT	BYTE exception status UINT vacuum pressure INT differential pressure Placeholders	Open
11 _{hex}	None	00 00 00 00 00 00 00 00 00 00	BYTE BYTE UINT INT	BYTE exception status BYTE trip point status UINT vacuum pressure INT differential pressure Placeholders	Open
12 _{hex}	None	00 00 00 00 00 00 00 00 00 00 00 00 00 00 00 00	REAL REAL	REAL vacuum pressure REAL differential pressure Placeholders	Open
13 _{hex}	None	00 00 00 00 00 00 00 00 00 00 00 00 00 00 00 00 00	BYTE REAL REAL	BYTE exception status REAL vacuum pressure REAL differential pressure Placeholders	Open
14 _{hex}	None	00 00 00 00 00 00 00 00 00 00 00 00 00 00 00 00 00 00	BYTE BYTE REAL REAL	BYTE exception status BYTE trip point status REAL vacuum pressure REAL differential pressure Placeholders	Open

Output I/O (from master)

Instance	Master data	Device data	Data type	Description	Type
100	00	None	BYTE	Bit 7 = High emission Bit 6 = Micro-Ion gauge ON Bit 0 = Degas ON	Vendor

B.2 Explicit message summary

Identity object

Service	Class	Instance	Attribute	Master data	Device data	Data type	Description	Type
0E _{hex}	1	1	1	None	00 5C _{hex}	UINT	Vendor identification	Open
0E _{hex}	1	1	2	None	00 1C _{hex}	UINT	Product type	Open
0E _{hex}	1	1	3	None	00 06	UINT	390002 product ID	Open
0E _{hex}	1	1	4	None	01 01	STRUCT	Firmware revision	Open
0E _{hex}	1	1	5	None	00 00	WORD	Status and fault information	Open
0E _{hex}	1	1	6	None	00 00 00 00	UDINT	Serial number	Open
0E _{hex}	1	1	7	None	"GP390"	S_STRING	Identification	Open
05 _{hex}	1	1	None	None	None		Reset module to power-up state	Open

DeviceNet object

Service	Class	Instance	Attribute	Master data	Device data	Data type	Description	Type
0E _{hex}	3	0	1	None	00 02	UINT	Object revision	Open
0E _{hex}	3	1	1	None	0	USINT	Get node address, range 0–63	Open
10 _{hex}	3	1	1	0	Success		Set node address if switch set to "PGM"	Open
0E _{hex}	3	1	2	None	0	USINT	Get baud rate, range 0–2	Open
10 _{hex}	3	1	2	0	Success		Set baud rate if switch set to "PGM"	Open
0E _{hex}	3	1	3	None	0	BOOL	Get bus-off interrupt, range 0–1	Open
0E _{hex}	3	1	4	None	0	USINT	Get bus-off counter, range 0–255	Open
10 _{hex}	3	1	4	0	Success		Set bus-off counter	Open
0E _{hex}	3	1	5	None	00 00	STRUCT	Get allocation choice, range 0–3 Get master ID, range 0–63	Open
4B _{hex}	3	1	None	03 00	Success	STRUCT	Set allocation choice, range 0–3 Set master ID, range 0–63	Open
4C _{hex}	3	1	None	3	Success	BYTE	Release allocation, range 0–3	Open

Assembly object

Service	Class	Instance	Attribute	Master data	Device data	Data type	Description	Type
0E _{hex}	4	0	65 _{hex}	None	5	USINT	Get I/O produced instance selection, range 1-20	Vendor
10 _{hex}	4	0	65 _{hex}	5	Success	USINT	Set I/O produced instance selection, range 1-20	Vendor
0E _{hex}	4	0	66 _{hex}	None	100	USINT	Get I/O consumed instance selection, range 0 or 100	Vendor
10 _{hex}	4	0	66 _{hex}	1	Success	USINT	Set I/O consumed instance selection, range 0 or 100	Vendor
0E _{hex}	4	1	3	None	00 00	UINT	Get UINT vacuum pressure	Open
0E _{hex}	4	2	3	None	00 00 00	STRUCT	Get BYTE exception status Get UINT vacuum pressure	Open
0E _{hex}	4	3	3	None	00 00 00 00	STRUCT	Get BYTE exception status Get BYTE trip point status Get UINT vacuum pressure	Open
0E _{hex}	4	4	3	None	00 00 00 00	REAL	Get REAL pressure	Open
0E _{hex}	4	5	3	None	00 00 00 00 00	STRUCT	Get BYTE exception status Get REAL vacuum pressure	Open
0E _{hex}	4	6	3	None	00 00 00 00 00 00	STRUCT	Get BYTE exception status Get BYTE trip point status Get REAL vacuum pressure	Open
0E _{hex}	4	0F _{hex}	3	None	00 00 00 00 00 00 00 00	UINT INT	Get UINT vacuum pressure Get INT differential pressure Placeholders	Open
0E _{hex}	4	10 _{hex}	3	None	00 00 00 00 00 00 00 00 00	BYTE UINT INT	Get BYTE exception status Get UINT vacuum pressure Get INT differential pressure Placeholders	Open
0E _{hex}	4	11 _{hex}	3	None	00 00 00 00 00 00 00 00 00 00	BYTE BYTE UINT INT	Get BYTE exception status Get BYTE trip point status Get UINT vacuum pressure Get INT differential pressure Placeholders	Open
0E _{hex}	4	12 _{hex}	3	None	00 00 00 00 00 00 00 00 00 00 00 00 00 00 00 00	REAL REAL	Get REAL vacuum pressure Get REAL differential pressure Placeholders	Open
0E _{hex}	4	13 _{hex}	3	None	00 00 00 00 00 00 00 00 00 00 00 00 00 00 00 00 00	BYTE REAL REAL REAL	Get BYTE exception status Get REAL vacuum pressure Get REAL differential pressure Placeholders	Open
0E _{hex}	4	14 _{hex}	3	None	00 00 00 00 00 00 00 00 00 00 00 00 00 00 00 00 00 00	BYTE BYTE REAL REAL REAL	Get BYTE exception status Get BYTE trip point status Get REAL vacuum pressure Get REAL differential pressure Placeholders	Open
0E _{hex}	4	64 _{hex}	3	None	00	BYTE	Get gauge status	Vendor
10 _{hex}	4	64 _{hex}	3	0	Success	BYTE	Set gauge status	Vendor

Connection object, explicit message connection

Service	Class	Instance	Attribute	Master data	Device data	Data type	Description	Type
0E _{hex}	5	1	1	None	3	USINT	Get state of the object, range 0–5	Open
0E _{hex}	5	1	2	None	0	USINT	Get instance type, explicit	Open
0E _{hex}	5	1	3	None	83 _{hex}	BYTE	Get transport class trigger	Open
0E _{hex}	5	1	4	None	FB 05	UINT	Get produced connection ID	Open
0E _{hex}	5	1	5	None	FC 05	UINT	Get consumed connection ID	Open
0E _{hex}	5	1	6	None	21 _{hex}	BYTE	Get initial communication characteristics	Open
0E _{hex}	5	1	7	None	18 00	UINT	Get produced connection size	Open
0E _{hex}	5	1	8	None	18 00	UINT	Get consumed connection size	Open
0E _{hex}	5	1	9	None	C4 _{hex} 09	UINT	Get expected packet rate, range 0–65535	Open
10 _{hex}	5	1	9	00 00	Success	UINT	Set expected packet rate	Open
0E _{hex}	5	1	0C _{hex}	None	1	USINT	Get watchdog timeout action, 1 or 3	Open
10 _{hex}	5	1	0C _{hex}	0	Success	UINT	Set watchdog timeout action	Open
0E _{hex}	5	1	0D _{hex}	None	00 00	UINT	Get produced connection path length	Open
0E _{hex}	5	1	0E _{hex}	None	4	EPATH	Get produced connection path	Open
0E _{hex}	5	1	0F _{hex}	None	00 00	UINT	Get consumed connection path length	Open
0E _{hex}	5	1	10 _{hex}	None	4	EPATH	Get consumed connection path	Open
0E _{hex}	5	1	11 _{hex}	None	00 00	UINT	Get production inhibit time	Open
05 _{hex}	5	1	None	None	Success	None	Reset inactivity/watchdog timer	Open

Connection object, I/O connection

Service	Class	Instance	Attribute	Master data	Device data	Data type	Description	Type
0E _{hex}	5	2	1	None	3	USINT	Get state of the object, range 0–5	Open
0E _{hex}	5	2	2	None	1	USINT	Get instance type, I/O	Open
0E _{hex}	5	2	3	None	82 _{hex}	BYTE	Get transport class trigger	Open
0E _{hex}	5	2	4	None	FF 03	UINT	Get produced connection ID	Open
0E _{hex}	5	2	5	None	FD 05	UINT	Get consumed connection ID	Open
0E _{hex}	5	2	6	None	01 _{hex}	BYTE	Get initial communication characteristics	Open
0E _{hex}	5	2	7	None	05 00	UINT	Get produced connection size	Open
0E _{hex}	5	2	8	None	01 00	UINT	Get consumed connection size	Open
0E _{hex}	5	2	9	None	00 00	UINT	Get expected packet rate, range 0–65535	Open
10 _{hex}	5	2	9	00 00	Success	UINT	Set expected packet rate	Open
0E _{hex}	5	2	0C _{hex}	None	0	USINT	Get watchdog timeout action	Open
0E _{hex}	5	2	0D _{hex}	None	06 00	UINT	Get produced connection path length	Open
0E _{hex}	5	2	0E _{hex}	None	5	EPATH	Set produced connection path length, 1–5 or 15–20	Open
0E _{hex}	5	2	0F _{hex}	None	06 00	UINT	Get consumed connection path length	Open
0E _{hex}	5	2	10 _{hex}	None	1	EPATH	Set consumed connection path length, 0 or 1	Open
0E _{hex}	5	2	11 _{hex}	None	00 00	UINT	Get production inhibit time	Open
05 _{hex}	5	1	None	None	Success	None	Reset inactivity/watchdog timer	Open

Connection object, COS/cyclic connection

Service	Class	Instance	Attribute	Master data	Device data	Data type	Description	Type
0E _{hex}	5	4	1	None	3	USINT	Get state of the Object, range 0-5	Open
0E _{hex}	5	4	2	None	1	USINT	Get instance type, I/O	Open
0E _{hex}	5	4	3	None	0 _{hex} 12	BYTE	Get transport class trigger	Open
0E _{hex}	5	4	4	None	7F 03	UINT	Get produced connection ID	Open
0E _{hex}	5	4	5	None	FA 05	UINT	Get consumed connection ID	Open
0E _{hex}	5	4	6	None	01 _{hex}	BYTE	Get initial communication characteristics	Open
0E _{hex}	5	4	7	None	05 00	UINT	Get produced connection size	Open
0E _{hex}	5	4	8	None	01 00	UINT	Get consumed connection size	Open
0E _{hex}	5	4	9	None	00 00	UINT	Get expected packet rate, range 0-65535	Open
10 _{hex}	5	4		00 00	Success		Set expected packet rate	Open
0E _{hex}	5	4	0C _{hex}	None	0	USINT	Get watchdog timeout action	Open
0E _{hex}	5	4	0D _{hex}	None	06 00	UINT	Get produced connection path length	Open
0E _{hex}	5	4	0E _{hex}	None	5	EPATH	Set produced connection path, 1 or 2 or 4 or 5	Open
0E _{hex}	5	4	0F _{hex}	None	04 00	UINT	Get consumed connection path length	Open
0E _{hex}	5	4	10 _{hex}	None	1	EPATH	Set consumed connection path, 0 or 1	Open
0E _{hex}	5	2	11 _{hex}	None	00 00	UINT	Get production inhibit time	Open
10 _{hex}	5	2	11 _{hex}	00 00	Success	UINT	Set production inhibit time	Open
05 _{hex}	5	1	None	None	Success	None	Reset inactivity/watchdog timer	Open

Acknowledge handler object

Service	Class	Instance	Attribute	Master data	Device data	Data type	Description	Type
0E _{hex}	2B _{hex}	1	1	None	16 00	UINT	Get acknowledge timer	Open
10 _{hex}	2B _{hex}	1	1	16 00	Success + data	UINT	Set acknowledge timer	Open
0E _{hex}	2B _{hex}	1	2	None	1	USINT	Get acknowledge retry limit	Open
10 _{hex}	2B _{hex}	1	2	1	Success	USINT	Set acknowledge retry limit	Open
0E _{hex}	2B _{hex}	1	3	None	1	UINT	Get producing connection instance	Open

Device supervisor object

Service	Class	Instance	Attribute	Master data	Device data	Data type	Description	Type
0E _{hex}	30 _{hex}	1	3	None	"CG"	SSTRING	Get device type, combination gauge	Open
0E _{hex}	30 _{hex}	1	4	None	"E54-0997"	SSTRING	Get revision level, SEMI S/A standard	Open
0E _{hex}	30 _{hex}	1	5	None	""	SSTRING	Get manufacturer's name, "GRANVILLE-PHILLIPS"	Open
0E _{hex}	30 _{hex}	1	6	None	"390601"	SSTRING	Get manufacturer's model number	Open
0E _{hex}	30 _{hex}	1	7	None	"1.01"	SSTRING	Get software revision level	Open
0E _{hex}	30 _{hex}	1	8	None	"1.01"	SSTRING	Get hardware revision level	Open
0E _{hex}	30 _{hex}	1	0B _{hex}	None	4	USINT	Get device status	Open
0E _{hex}	30 _{hex}	1	0C _{hex}	None	0	BYTE	Get exception status	Open
0E _{hex}	30 _{hex}	1	0F _{hex}	None	0	BOOL	Get alarm enable	Open
10 _{hex}	30 _{hex}	1	0F _{hex}	0	Success		Set alarm enable	
0E _{hex}	30 _{hex}	1	10 _{hex}	None	0	BOOL	Get warning enable	Open
10 _{hex}	30 _{hex}	1	10 _{hex}	0	Success		Set warning enable	
05 _{hex}	30 _{hex}	1	None	None	Success	None	Reset object service	Open
06 _{hex}	30 _{hex}	1	None	None	Success	None	Start device execution (No effect on device)	Open
4B _{hex}	30 _{hex}	1	None	None	Success	None	Abort device activity (No effect on device)	Open
4C _{hex}	30 _{hex}	1	None	None	Success	None	Recover from abort state (No effect on device)	Open
4D _{hex}	30 _{hex}	1	None	None	Success	None	Perform diagnostics (No effect on device)	Open

Analog sensor object, instance 0

Service	Class	Instance	Attribute	Master data	Device data	Data type	Description	Type
0E _{hex}	31 _{hex}	0	5E _{hex}	None	00 00 00 00	REAL	Active value, vacuum pressure	Open
0E _{hex}	31 _{hex}	0	5F _{hex}	None	01 00	UINT	Active instance number, 1 or 2	Open
0E _{hex}	31 _{hex}	0	60 _{hex}	None	3	USINT	Number of gauges, 2 or 3	Open
0E _{hex}	31 _{hex}	0	63 _{hex}	None	1	UINT	Instance selector, 1 for combination gauge	Open

Analog sensor object, instance 1, Conductron sensor

Service	Class	Instance	Attribute	Master data	Device data	Data type	Description	Type
0E _{hex}	31 _{hex}	1	3	None	CA _{hex}	USINT	Get data type	Open
0E _{hex}	31 _{hex}	1	4	None	01 03	UINT	Get pressure unit, 769 = Torr	Open
10 _{hex}	31 _{hex}	1	4	None	01 03	UINT	Set pressure unit, 769 or 776 or 777 769 = Torr 776 = mbar 777 = Pa	Open
0E _{hex}	31 _{hex}	1	5	None	1	BOOL	Get reading valid, 0 or 1	Open
0E _{hex}	31 _{hex}	1	6	None	00 00 00 00	REAL	Get pressure reading	Open
0E _{hex}	31 _{hex}	1	7	None	0	BYTE	Get status, alarm or warning	Open
0E _{hex}	31 _{hex}	1	22 _{hex}	None	C8 00	UINT	Get produce_trigger_delta	Open
10 _{hex}	31 _{hex}	1	22 _{hex}	C8 00	Success	UINT	Set produce_trigger_delta, 0 to 50000	Open
0E _{hex}	31 _{hex}	1	24 _{hex}	None	1	USINT	Get produce trigger delta data type	Open
0E _{hex}	31 _{hex}	1	63 _{hex}	None	02 00	UINT	Get subclass number	Open
0E _{hex}	31 _{hex}	1	67 _{hex}	None	25 00	UINT	Get maximum internal temperature	Vendor
0E _{hex}	31 _{hex}	1	68 _{hex}	None	25 00	UINT	Get current internal temperature	Vendor
4B _{hex}	31 _{hex}	1	None	None	None	None	Calibrate module at vacuum pressure	Open
4C _{hex}	31 _{hex}	1	None	None	None	None	Calibrate module at atmospheric pressure	Open

Analog sensor object, instance 2, Micro-Ion gauge

Service	Class	Instance	Attribute	Master data	Device data	Data type	Description	Type
0E _{hex}	31 _{hex}	2	3	None	CA _{hex}	USINT	Get data type	Open
0E _{hex}	31 _{hex}	2	4	None	01 03	UINT	Get pressure unit, 769 = Torr	Open
10 _{hex}	31 _{hex}	2	4	None	01 03	UINT	Set pressure unit, 769 or 776 or 777 769 = Torr 776 = mbar 777 = Pa	Open
0E _{hex}	31 _{hex}	2	5	None	1	BOOL	Get reading valid, 0 or 1	Open
0E _{hex}	31 _{hex}	2	6	None	00 00 00 00	REAL	Get pressure reading	Open
0E _{hex}	31 _{hex}	2	7	None	0	BYTE	Get status, alarm or warning	Open
0E _{hex}	31 _{hex}	2	22 _{hex}	None	C8 00	UINT	Get produce_trigger_delta	Open
10 _{hex}	31 _{hex}	2	22 _{hex}	C8 00	Success	UINT	Set produce_trigger_delta	
0E _{hex}	31 _{hex}	2	24 _{hex}	None	1	USINT	Get produce trigger delta data type, percent	Open
0E _{hex}	31 _{hex}	2	58 _{hex}	None	0	BOOL	Get degas state	Open
10 _{hex}	31 _{hex}	2	58 _{hex}	0	Success	BOOL	Set degas state 0 = Degas is OFF, 1 = Degas is ON	Vendor
0E _{hex}	31 _{hex}	2	59 _{hex}	None	0	USINT	Get active filament Bit 0 = Filament 1 Bit 1 = Filament 2	Open
0E _{hex}	31 _{hex}	2	5B _{hex}	None	00 00 00 00	REAL	Get emission current	Open
0E _{hex}	31 _{hex}	2	5D _{hex}	None	0	BOOL	Get Micro-Ion gauge ON/OFF state	Open
10 _{hex}	31 _{hex}	2	5D _{hex}	0	Success	BOOL	Set Micro-Ion gauge ON/OFF state 0 = Turn gauge OFF 1 = Turn gauge ON	Open
0E _{hex}	31 _{hex}	2	5E _{hex}	None	00 00	UINT	Get sensor warning	Open
0E _{hex}	31 _{hex}	2	5F _{hex}	None	00 00	UINT	Get sensor alarm	Open
0E _{hex}	31 _{hex}	2	60 _{hex}	None	1	BYTE	Get status extension	Open
0E _{hex}	31 _{hex}	2	63 _{hex}	None	05 00	UINT	Get subclass number	Open
0E _{hex}	31 _{hex}	2	67 _{hex}	None	25 00	UINT	Get maximum internal temperature	Vendor
0E _{hex}	31 _{hex}	2	68 _{hex}	None	25 00	UINT	Get current internal temperature	Vendor
0E _{hex}	31 _{hex}	2	69 _{hex}	None	0	USINT	Get filament mode	Vendor
10 _{hex}	31 _{hex}	2	69 _{hex}	0	Success	USINT	Set filament mode 0 = Automatic 1 = Alternating 2 = Manual	Vendor
0E _{hex}	31 _{hex}	2	6A _{hex}	None	00 00	UINT	Get Micro-Ion gauge delay time	Vendor
10 _{hex}	31 _{hex}	2	6A _{hex}	0	Success	UINT	Set Micro-Ion gauge delay time, 0 to 600 sec.	Vendor
0E _{hex}	31 _{hex}	2	6B _{hex}	None	2	USINT	Get Micro-Ion gauge filament type 2 = Yttria-coated iridium 3 = Tungsten	Vendor
61 _{hex}	31 _{hex}	2	None	0	Success	USINT	Set degas state 0 = Degas is OFF, 1 = Degas is ON	Open
62 _{hex}	31 _{hex}	2	None	0	Success	USINT	Set Micro-Ion gauge ON/OFF state 0 = Turn gauge OFF 1 = Turn gauge ON	Open
63 _{hex}	31 _{hex}	2	None	None	Success	None	Clear emission OFF alarm	Open

Analog sensor object, instance 3, differential pressure

Service	Class	Instance	Attribute	Master data	Device data	Data type	Description	Type
0E _{hex}	31 _{hex}	3	3	None	CA _{hex}	USINT	Get data type	Open
0E _{hex}	31 _{hex}	3	4	None	01 03	UINT	Get pressure unit, 769 = Torr	Open
10 _{hex}	31 _{hex}	3	4	None	01 03	UINT	Set pressure unit, 769 or 776 or 777 769 = Torr 776 = mbar 777 = Pa	Open
0E _{hex}	31 _{hex}	3	5	None	1	BOOL	Get reading valid, 0 or 1	Open
0E _{hex}	31 _{hex}	3	6	None	00 00 00 00	REAL	Get pressure reading	Open
0E _{hex}	31 _{hex}	3	7	None	0	BYTE	Get status, alarm or warning	Open
0E _{hex}	31 _{hex}	3	22 _{hex}	None	C8 00	UINT	Get produce_trigger_delta	Open
10 _{hex}	31 _{hex}	3	22 _{hex}	C8 00	Success	UINT	Set produce_trigger_delta	Open
0E _{hex}	31 _{hex}	3	24 _{hex}	None	01	USINT	Get produce trigger delta data type, percent	Open
0E _{hex}	31 _{hex}	3	63 _{hex}	None	03 00	UINT	Get subclass number	Open
0E _{hex}	31 _{hex}	3	67 _{hex}	None	25 00	UINT	Get maximum internal temperature	Vendor
0E _{hex}	31 _{hex}	3	68 _{hex}	None	25 00	UINT	Get current internal temperature	Vendor
4B _{hex}	31 _{hex}	3	None	None	None	None	Zero adjust, pressure diaphragm sensor	Open
4C _{hex}	31 _{hex}	3	None	None	None	None	Gain adjust, pressure diaphragm sensor	Open

Trip point object, instance 1, relay 1

Service	Class	Instance	Attribute	Master data	Device data	Data type	Description	Type
0E _{hex}	35 _{hex}	1	5	None	00 00 00 00	REAL	Get pressure at which relay 1 activates	Open
10 _{hex}	35 _{hex}	1	5	00 00 00 00	Success	REAL	Set pressure at which relay 1 activates	Open
0E _{hex}	35 _{hex}	1	6	None	0	BOOL	Get relay 1 enabled/disabled status 0 = Relay 1 is disabled 1 = Relay 1 is enabled	Open
10 _{hex}	35 _{hex}	1	6	0	Success	BOOL	Set relay 1 enabled/disabled status	Open
0E _{hex}	35 _{hex}	1	7	None	0	BOOL	Get relay 1 activation/deactivation status 0 = Relay 1 is deactivated 1 = Relay 1 is activated	Open
0E _{hex}	35 _{hex}	1	8	None	0	BOOL	Get relay 1 polarity 0 = Activate with decreasing pressure 1 = Activate with increasing pressure	Open
10 _{hex}	35 _{hex}	1	8	0	Success	BOOL	Set relay 1 polarity	
0E _{hex}	35 _{hex}	1	9	None	0	USINT	Get override status 0 = Normal 2 = Force false	Open
0E _{hex}	35 _{hex}	1	0A _{hex}	None	00 00 00 00	REAL	Get relay 1 hysteresis as a percentage of pressure if source path from analog object = 24 00 or as a pressure value if source path from analog object = 24 03	Open
10 _{hex}	35 _{hex}	1	0A _{hex}	0	Success	REAL	Set relay 1 hysteresis	Open
0E _{hex}	35 _{hex}	1	0C _{hex}	None	24 01	EPATH	Get destination path, 01	Open
0E _{hex}	35 _{hex}	1	0D _{hex}	None	0	BOOL	Get output to output object	Open
0E _{hex}	35 _{hex}	1	0E _{hex}	None	24 00	EPATH	Get source path from analog object	Open
10 _{hex}	35 _{hex}	1	0E _{hex}	None	24 00	EPATH	Set relay 1 assignment 24 00 for vacuum pressure 24 03 for differential pressure	Open
0E _{hex}	35 _{hex}	1	0F _{hex}	None	00 00 24 00	REAL	Get input data from analog sensor object	Open
0E _{hex}	35 _{hex}	1	11 _{hex}	None	CA _{hex}	USINT	Get data type, CA _{hex}	Open

Trip point object, instance 2, relay 2

Service	Class	Instance	Attribute	Master data	Device data	Data type	Description	Type
0E _{hex}	35 _{hex}	2	5	None	00 00 00 00	REAL	Get pressure at which relay 2 activates	Open
10 _{hex}	35 _{hex}	2	5	00 00 00 00	Success	REAL	Set pressure at which relay 2 activates	Open
0E _{hex}	35 _{hex}	2	6	None	0	BOOL	Get relay 2 enabled/disabled status 0 = Relay 2 is disabled 1 = Relay 2 is enabled	Open
10 _{hex}	35 _{hex}	2	6	0	Success	BOOL	Set relay2 enabled/disabled status	Open
0E _{hex}	35 _{hex}	2	7	None	0	BOOL	Get relay 2 activation/deactivation status 0 = Relay 2 is deactivated 1 = Relay 2 is activated	Open
0E _{hex}	35 _{hex}	2	8	None	0	BOOL	Get relay 2 polarity 0 = Activate with decreasing pressure 1 = Activate with increasing pressure	Open
10 _{hex}	35 _{hex}	2	8	0	Success	BOOL	Set relay 2 polarity	Open
0E _{hex}	35 _{hex}	2	9	None	0	USINT	Get override status 0 = Normal 2 = Force false	Open
0E _{hex}	35 _{hex}	2	0A _{hex}	None	00 00 00 00	REAL	Get relay 2 hysteresis as a percentage of pressure if source path from analog object = 24 00 or as a pressure value if source path from analog object = 24 03	Open
10 _{hex}		2	0A _{hex}	0	Success	REAL	Set relay 2 hysteresis	Open
0E _{hex}	35 _{hex}	2	0C _{hex}	None	24 02	EPATH	Get destination path, 01	Open
0E _{hex}	35 _{hex}	2	0D _{hex}	None	0	BOOL	Get output to output object	Open
0E _{hex}	35 _{hex}	2	0E _{hex}	None	24 00	EPATH	Get source path from analog object	Open
10 _{hex}	35 _{hex}	2	0E _{hex}	None	24 00	EPATH	Set relay 2 assignment 24 00 for vacuum pressure 24 03 for differential pressure	Open
0E _{hex}	35 _{hex}	2	0F _{hex}	None	00 00 24 00	REAL	Get input data from analog sensor object	Open
0E _{hex}	35 _{hex}	2	11 _{hex}	None	CA _{hex}	USINT	Get data type, CA _{hex}	Open

Trip point object, instance 3, relay 3

Service	Class	Instance	Attribute	Master data	Device data	Data type	Description	Type
0E _{hex}	35 _{hex}	3	5	None	00 00 00 00	REAL	Get pressure at which relay 3 activates	Open
10 _{hex}	35 _{hex}	3	5	00 00 00 00	Success		Set pressure at which relay 3 activates	Open
0E _{hex}	35 _{hex}	3	6	None	0	BOOL	Get relay 3 enabled/disabled status 0 = Relay 3 is disabled 1 = Relay 3 is enabled	Open
10 _{hex}	35 _{hex}	3	6	0	Success	BOOL	Set relay 3 enabled/disabled status	Open
0E _{hex}	35 _{hex}	3	7	None	0	BOOL	Get relay 3 activation/deactivation status 0 = Relay 3 is deactivated 1 = Relay 3 is activated	Open
0E _{hex}	35 _{hex}	3	8	None	0	BOOL	Get relay 3 polarity 0 = Activate with decreasing pressure 1 = Activate with increasing pressure	Open
10 _{hex}	35 _{hex}	3	8	0	Success	BOOL	Set relay 3 polarity	Open
0E _{hex}	35 _{hex}	3	9	None	0	USINT	Get override status 0 = Normal 2 = Force false	Open
0E _{hex}	35 _{hex}	3	0A _{hex}	None	00 00 00 00	REAL	Get relay 3 hysteresis as a percentage of pressure if source path from analog object = 24 00 or as a pressure value if source path from analog object = 24 03	Open
10 _{hex}	35 _{hex}	3	0A _{hex}	0	Success	REAL	Set relay 3 hysteresis	Open
0E _{hex}	35 _{hex}	3	0C _{hex}	None	24 03	EPATH	Get destination path, 01	Open
0E _{hex}	35 _{hex}	3	0D _{hex}	None	0	BOOL	Get output to output object	Open
0E _{hex}	35 _{hex}	3	0E _{hex}	None	24 00	EPATH	Get source path from analog object	Open
10 _{hex}	35 _{hex}	3	0E _{hex}	None	24 00	EPATH	Set relay 3 assignment 24 00 for vacuum pressure 24 03 for differential pressure	Open
0E _{hex}	35 _{hex}	3	0F _{hex}	None	00 00 24 00	REAL	Get input data from analog sensor object	Open
0E _{hex}	35 _{hex}	3	11 _{hex}	None	CA _{hex}	USINT	Get data type, CA _{hex}	Open

Trip point object, instance 4, emission range

Service	Class	Instance	Attribute	Master data	Device data	Data type	Description	Type
0E _{hex}	35 _{hex}	4	5	None	38 D1 B7 17 _{hex}	REAL	GET trip point value emission ranging (5E ⁻⁶)	Open
10 _{hex}	35 _{hex}	4	5	38 D1 B7 17 _{hex}	Success	REAL	SET trip point value, emission ranging (5E ⁻⁶)	Open
0E _{hex}	35 _{hex}	4	6	None	0	BOOL	GET trip point enable, emission ranging	Open
0E _{hex}	35 _{hex}	4	7	None	0	BOOL	GET trip point status, emission ranging	Open
0E _{hex}	35 _{hex}	4	9	None	0	USINT	GET override status, 0 = normal, 1 = force false	Open
0E _{hex}	35 _{hex}	4	0C _{hex}	None	24 04	EPATH	GET destination path, 01, 02, or 03	Open
0E _{hex}	35 _{hex}	4	0D _{hex}	None	0	BOOL	GET output to output object	Open
0E _{hex}	35 _{hex}	4	0E _{hex}	None	24 02	EPATH	GET source path from analog object	Open
0E _{hex}	35 _{hex}	4	0F _{hex}	None	00 00 00 00	REAL	GET REAL pressure data from analog sensor object (5E ⁻⁶)	Open
0E _{hex}	35 _{hex}	4	11 _{hex}	None	CA _{hex}	USINT	GET data type, CA _{hex} or C3 _{hex}	Open

Discrete output point object

Service	Class	Instance	Attribute	Master data	Device data	Data type	Description	Type
0E _{hex}	09 _{hex}	1	3	None	0	BOOL	Get output point value controlling relay 1	Open
0E _{hex}	09 _{hex}	2	3	None	0	BOOL	Get output point value controlling relay 2	Open
0E _{hex}	09 _{hex}	3	3	None	0	BOOL	Get output point value controlling relay 3	Open
0E _{hex}	09 _{hex}	4	3	None	0	BOOL	Get output point value controlling emission	Open

Appendix C Theory of Operation

C.1 Module operation

The Micro-Ion ATM vacuum gauge module consists of four separate pressure measuring devices: a Micro-Ion gauge (Bayard-Alpert type ionization gauge), a Conductron heat-loss sensor, and two Piezo resistive pressure diaphragm sensors.

One Piezo resistive diaphragm sensor measures atmospheric pressure, and one Piezo resistive diaphragm sensor measures vacuum pressure. Used together, the two pressure diaphragm sensors determine the differential between atmosphere and vacuum pressures.

Figure C-1 illustrates the Micro-Ion gauge, Conductron sensor, and vacuum pressure diaphragm sensors. The atmospheric pressure diaphragm sensor is located in the module's electronics assembly, illustrated on page 117.

Figure C-1 Micro-Ion gauge, Conductron sensor, and pressure diaphragm sensors

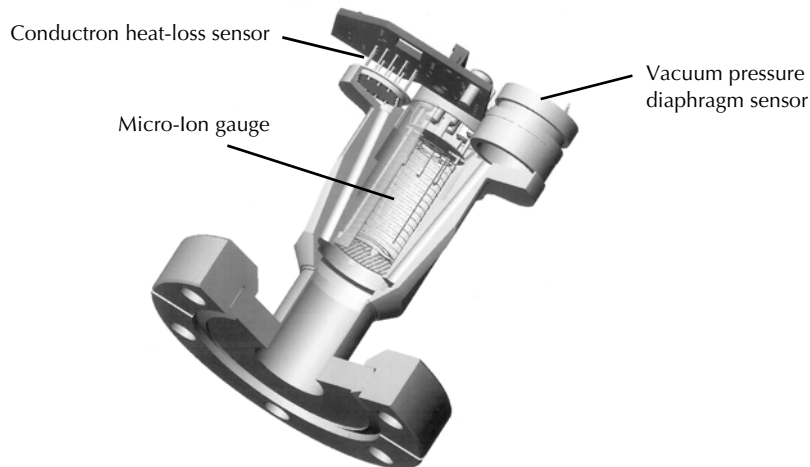

C.2 Auto ranging

As the vacuum system pumps down from atmosphere, the Conductron sensor measures pressure until a sufficiently low pressure level is achieved, then automatically turns ON the Micro-Ion gauge in the low emission mode. As pressure decreases, the Micro Ion gauge switches from low emission to high emission. As pressure increases, the opposite occurs at slightly higher pressures.

Whenever pressure is within the measurement range of both the Conductron sensor and the Micro-Ion gauge, the control electronics

switches sensors, as illustrated in Figure C-2.

Figure C-2 Auto ranging actuation points

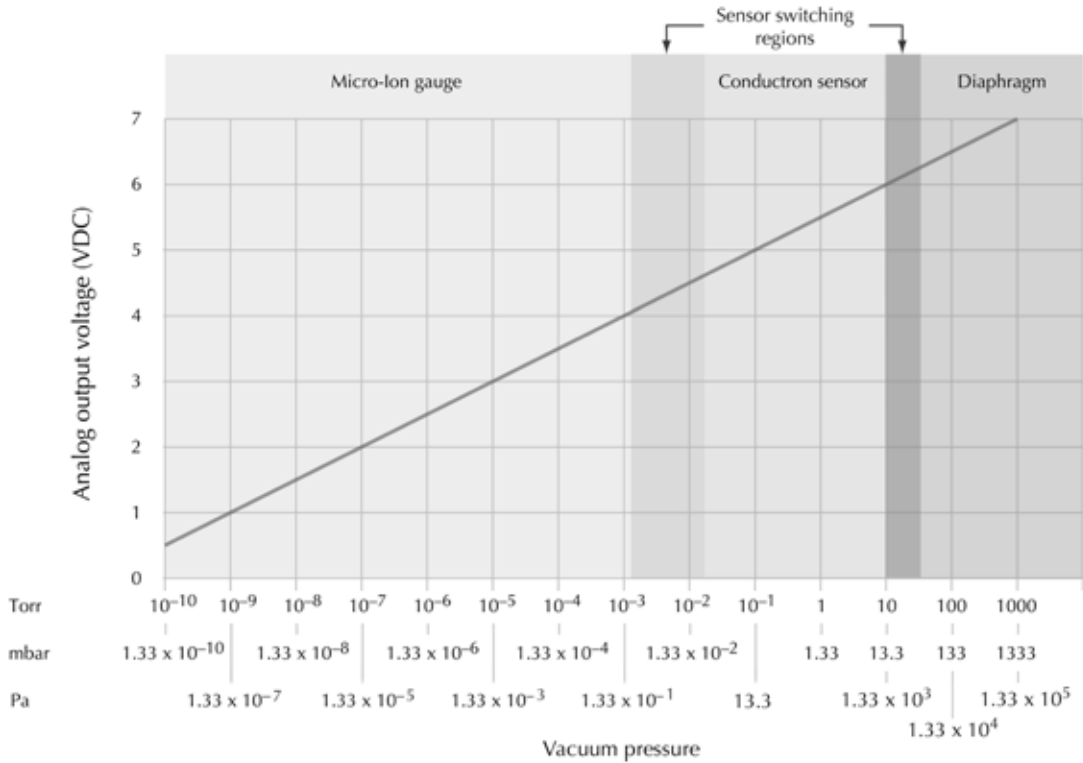

C.3 Micro-Ion gauge operation

The functional parts of the Micro-Ion gauge are the filaments (cathodes), grid (anode) and ion collectors. These electrodes are maintained by the controller at +30, +180, and 0 volts, relative to ground, respectively.

The filaments are heated to such a temperature that electrons are emitted and accelerated toward the grid by the potential difference between the grid and filaments. All of the electrons eventually collide with the grid, but many first traverse the region inside the grid many times.

When an electron collides with a gas molecule, an electron is dislodged from the molecule, leaving the molecule with a positive charge, thereby transforming the molecule into a positive ion. Most ions then accelerate to the ion collectors. The rate at which electrons collide with the ion collectors is proportional to the density of the gas molecules; therefore, ion current is proportional to gas density (or pressure, at constant temperature).

The amount of ion current for a given emission current and pressure depends on the Micro-Ion gauge design. This gives rise to the definition of ionization gauge sensitivity, frequently denoted by "S":

$$S = \frac{\text{Ion current}}{\text{Emission current} \times \text{Pressure}}$$

The module electronics for the gauge varies the heating current to the filament to maintain a constant electron emission and measures the ion current to the ion collectors. The pressure is then calculated from these data.

Micro-Ion gauge degas is accomplished by increasing the emission current to 15 mA and raising the grid bias to 250 Vdc, resulting in an increased grid temperature to drive off adsorbed gases.

C.4 Conductron sensor operation

The Conductron heat-loss sensor uses Granville-Phillips' Conductron sensor proprietary geometry and control circuitry. The sensor is comprised of two coplanar wire elements: a sensing wire, and a compensating wire that corrects for ambient conditions. The resistance of the sensing wire increases as its temperature increases. The controller continually adjusts a heating current that flows through the sensing wire to keep the sensor at a regulated temperature.

If pressure increases, the heat loss through gas conduction from the sensor increases, and the sensor temperature decreases, causing the resistance of the sensor to decrease. As this occurs, an error amplifier senses a change in the resistance differential between the sensor element and the compensation element, and generates an increase in the heating current through the sensor. The increased current through the sensor increases its temperature (and its resistance), and the resistance differential between the two elements is reestablished at a higher sensor input voltage and current. When calibrated, using a series of pressures and ambient temperatures, the input voltage and current are measured as an indication of the system pressure.

C.5 Piezo resistive diaphragm sensor operation

The module contains two Piezo resistive pressure diaphragm sensors.

One Piezo resistive diaphragm sensor measures atmospheric pressure, and one Piezo resistive diaphragm sensor measures vacuum pressure. The comparison of the pressures measured by the two pressure diaphragm sensors determines the differential between atmosphere and vacuum pressures.

Changes in differential pressure cause activation and deactivation of relays at programmable trip points that correspond to increasing and decreasing differential pressures.

Index

- A**
- Address offset **81**
 - Analog output
 - calibration **34**
 - functions **29**
 - Micro-Ion gauge degas **33**
 - Micro-Ion gauge ON/OFF **32**
 - operational tasks **29**
 - reading pressure **31**
 - wiring for **21**
 - Appendixes
 - Messaging Summary **129**
 - Specifications **121**
 - Theory of Operation **143**
 - Assembling and connecting wiring **19**
 - Atmospheric pressure **12**
 - Attaching module to vacuum chamber **18**
 - Auto ranging **143**
- B**
- Baud rate **82**
- C**
- Calibration
 - atmospheric pressure **35, 65, 99**
 - vacuum pressure **35, 65, 100**
 - Cautions and warnings **9**
 - CE Mark **20**
 - Chapters
 - Analog Operation **29**
 - Before You Begin **9**
 - DeviceNet Operation **37**
 - Installation **15**
 - Maintenance **111**
 - Operation Overview **25**
 - Optional Display **107**
 - RS-485 Operation **73**
 - Conductron sensor
 - specifications **126**
 - theory of operation **145**
 - Customer service **14, 111**
- D**
- Damage requiring service **111**
 - Defaults
 - filament mode **126**
 - Definitions of terms
 - address **13**
 - atmospheric pressure **12**
 - atmospheric pressure diaphragm sensor **12**
 - attribute **13**
 - BOOL data **14**
 - BYTE data **14**
 - class **13**
 - Conductron sensor **12**
 - data rate **13**
 - device data **13**
 - device type **14**
 - differential pressure **12**
 - electronics assembly **12**
 - EPATH **14**
 - explicit messages **13**
 - gauge assembly **12**
 - instance **13**
 - INT data **14**
 - master data **13**
 - Micro-Ion gauge **12**
 - module **12**
 - polled I/O messages **13**
 - REAL data **14**
 - SSTRING data **14**
 - STRUCT data **14**
 - UINT data **14**
 - USINT data **14**
 - vacuum pressure **12**
 - vacuum pressure diaphragm sensor **12**
 - WORD data **14**
 - degas **62, 63, 75, 96, 114**
 - DeviceNet data conversion **47**
 - DeviceNet messaging summary
 - explicit messages **130**
 - polled I/O **129**
 - DeviceNet output
 - calibration **65**
 - communication configuration **43**
 - data conversion **47**
 - error codes **68, 115**

- factory defaults **67**
- functions **37**
- get active filament **61**
- get Micro-Ion gauge degas ON/OFF state **63**
- get Micro-Ion gauge ON/OFF status **59**
- get relay activation/deactivation status **56**
- get relay assignments **57**
- get relay enable/disable status **55**
- get relay trip point **55**
- get revision levels **66**
- get temperature **51**
- get vacuum or differential pressure **48**
- initiate or terminate Micro-Ion gauge degas **62**
- Micro-Ion gauge controls **58**
- Micro-Ion gauge filament mode **60**
- operational tasks **39**
- pressure unit **47**
- rate switch **41**
- relays **51**
- reset to power-up state **66**
- set or get Micro-Ion gauge delay time **59**
- set or get Micro-Ion gauge emission current **63**
- set or get pressure unit **47**
- set relay hysteresis **57**
- status LEDs **41**
- switches and indicators **40**
- turn Micro-Ion gauge ON or OFF **58**
- wiring **22**

DeviceNet protocol

- for Micro-Ion ATM module **39**
- performance with **38**

Differential pressure **12**

Dimensions of module **128**

E

Electronics assembly **12**

Error conditions

- DeviceNet **68, 115**
- module status hexadecimal bits **103, 115**
- module status strings **101, 115**
- optional display **108**
- RS-485 **75, 114**
- symptoms, causes, and solutions **112**

Explicit messages **130**

FFactory defaults **67, 106**

Fittings

- ConFlat flange **18**
- KF flange **18**
- VCR type **18**

G

Gauge assembly

- definition of **12**
- replacement of **118**

IImplosion / Explosion **10**

Installation

- analog output **21**
- assembling and connecting wiring **19**
- attaching module to vacuum chamber **18**
- CE mark compliance **20**
- ConFlat flange **18**
- connecting cable **19**
- DeviceNet wiring **22**
- gauge OFF/degas wiring **21**
- grounding **22**
- installing pressure relief devices **15**
- KF flange **18**
- locating module **16**
- module components **15**
- module power supply **20**
- procedure **16**
- radio frequency interference (RFI) **24**
- relay wiring **21**
- RS-485 wiring **21**
- VCR type fitting **18**

LLETHAL VOLTAGES **10****M**

Maintenance

- damage requiring service **111**
- Micro-Ion gauge continuity test **116**
- overpressure shutdown **116**
- replacing gauge assembly **118**
- returning a damaged module **119**

- symptoms, causes, and solutions **112**
- troubleshooting **111**
- troubleshooting precautions **112**
- Micro-Ion gauge
 - automatic filament selection **28**
 - continuity test **116**
 - controls **58**
 - degas **33, 62, 96**
 - degas ON/OFF state **63, 96**
 - degas time **97**
 - delay ON/OFF state **90**
 - delay time **59, 91**
 - emission current **63, 97, 99**
 - filament mode **60, 92**
 - filament mode defaults **126**
 - filament status **61, 96**
 - ON/OFF status **59, 88**
 - pressure indication when OFF **89**
 - specifications **126**
 - theory of operation **144**
 - turning ON or OFF **32, 58, 88**
 - wiring for **21**
- Module
 - components **15**
 - dimensions **128**
 - power supply **20**
 - reading firmware version **106**
 - resetting to factory defaults **106**
 - resetting to power-up state **66, 105**
- O**
- Operation
 - analog **25**
 - analog output **29**
 - automatic filament selection **28**
 - DeviceNet **25**
 - DeviceNet output **37**
 - preparing to operate module **29, 37, 73**
 - RS-485 **27**
 - RS-485 output **73**
- Optional display
 - capabilities **107**
 - differential pressure **107**
 - error conditions **108**
 - resolution **108**
- setting pressure indication for **82**
- vacuum pressure **107**
- Overpressure shutdown **116**
- P**
- Piezo resistive diaphragm sensor **145**
- Polled I/O **129**
- Pressure
 - data conversion **47**
 - differential **12**
 - measurement specifications **121**
 - reading differential **48, 83, 107**
 - reading vacuum **31, 48, 83, 107**
 - setting or reading atmospheric output **101**
 - vacuum **12**
- Pressure relief devices **15**
- Pressure unit
 - reading **47, 82, 107**
 - setting **47, 82**
- R**
- Radio frequency interference (RFI) **24**
- Rate switch **41**
- Reading and following instructions **11**
- Relays
 - activation/deactivation status **56, 88**
 - assignments for **57, 87**
 - configuring **51, 84**
 - enabled/disabled status **55, 87**
 - hysteresis **57, 84**
 - specifications **125**
 - wiring for **21**
- Returning a damaged module **119**
- RS-485 command set **78**
- RS-485 command structure **77**
- RS-485 commands **77**
 - ATM **27, 101**
 - DG **27, 96**
 - DGS **27, 96**
 - DGT **27, 97**
 - FAC **27, 106**
 - IDT **27, 91**
 - IG **27, 88**
 - IGM **27, 89**
 - IGS **27, 88**

IOD **27, 90**
PC **27, 84**
PCE **27, 87**
PCG **27, 87**
RD **27, 83**
RDD **27, 83**
RE **27, 99**
RF **27, 96**
RPCS **27, 88**
RS **27, 101**
RST **27, 105**
RSX **27, 103**
RU **27, 82**
SA **27, 81**
SB **27, 82**
SD **27, 82**
SER **27, 97**
SF **27, 92**
SU **27, 82**
TLU **27, 80**
TS **27, 99**
TZ **27, 100**
UNL **27, 80**
VER **27, 106**
yuiop **27, 82**

RS-485 output
 command set **78**
 command structure **77**
 commands **77**
 data timing and response **76**
 defaults **82**
 error codes **114**
 error responses **75**
 functions **73**
 module status strings **101**
 operational tasks **75**
 physical layer **74**
 status hexadecimal bits **103**
 status LEDs **30**
 symbols used in this manual **77**
 wiring for **21**

S
Set address offset **81**
setting baud rate **82**

Specifications
 Conductron heat-loss sensor **126**
 filament mode **126**
 Micro-Ion gauge **126**
 optional trip point relays **125**
 outputs and indicators **123**
 pressure measurement **121**
 temperature **122**

Status LEDs **30, 41**
Symbols used in this manual **77**
System Grounding **10**

T
Temperature
 specifications **122**

Theory of operation
 auto ranging **143**
 Conductron sensor **145**
 Micro-Ion gauge **144**
 module **143**
 Piezo resistive diaphragm sensor **145**

Toggling locked functions **80**

Troubleshooting
 precautions **112**
 symptoms, causes, and solutions **112**

U
Unlocking interface functions **80**

V
Vacuum pressure **12**

W
Wiring
 analog output **21**
 assembling and connecting **19**
 CE Mark compliance **20**
 connecting cable **19**
 DeviceNet **22**
 gauge OFF/degas **21**
 grounding **22**
 module power supply **20**
 relays **21**
 RS-485 output **21**

Series 390

Granville-Phillips® Series 390 Micro-Ion® ATM Four-Sensor Combination Vacuum Gauge Module with DeviceNet™ and RS-485 Interface, and Analog Output

GRANVILLE-PHILLIPS®

Customer Service/Support

For customer service within USA, 8 AM to 5 PM
Mountain Time Zone, weekdays excluding holidays:

Granville-Phillips

6450 Dry Creek Parkway
Longmont, CO 80503 USA

Phone: +1-800-776-6543

Phone: +1-303-652-4400

FAX: +1-303-652-2844

Email: co-csr@brooks.com

Brooks Automation, Inc.

15 Elizabeth Drive
Chelmsford, MA 01824 USA

Phone: +1-978-262-2400

For customer service, 24 hours per day, 7 days per week,
every day of the year including holidays within the USA:

Phone: +1-800-367-4887

www.brooks.com

Instruction Manual

Instruction manual part number 390002

Revision E - August 2013

