



120466-P1  
Rev B, 1/98  
Instruction Manual

# **MKS Type 670B High Accuracy Signal Conditioner**

---

Six Shattuck Road  
Andover, MA 01810-2449  
(800) 227-8766 or (978) 975-2350

Fax: (978) 975-0093  
E-mail: [mks@mksinst.com](mailto:mks@mksinst.com)  
Web site: <http://www.mksinst.com>



## WARRANTY

### Type 670B Equipment

MKS Instruments, Inc. (**MKS**) warrants that the equipment described above (the "equipment") manufactured by **MKS** shall be free from defects in materials and workmanship for a period of one year from date of shipment and will for a period of two years from the date of shipment, correctly perform all date-related operations, including without limitation accepting data entry, sequencing, sorting, comparing, and reporting, regardless of the date the operation is performed or the date involved in the operation, provided that, if the equipment exchanges data or is otherwise used with equipment, software, or other products of others, such products of others themselves correctly perform all date-related operations and store and transmit dates and date-related data in a format compatible with **MKS** equipment. THIS WARRANTY IS **MKS'** SOLE WARRANTY CONCERNING DATE-RELATED OPERATIONS.

For the period commencing with the date of shipment of this equipment and ending one year later in the case of defects in materials and workmanship, but two years later in the case of failure to comply with the date-related operations warranty, **MKS** will, at its option, either repair or replace any part which is defective in materials or workmanship or with respect to the date-related operations warranty without charge to the purchaser. The foregoing shall constitute the exclusive and sole remedy of the purchaser for any breach by **MKS** of this warranty.

The purchaser, before returning any equipment covered by this warranty, which is asserted to be defective by the purchaser, shall make specific written arrangements with respect to the responsibility for shipping the equipment and handling any other incidental charges with the **MKS** sales representative or distributor from which the equipment was purchased or, in the case of a direct purchase from **MKS**, with the **MKS** home office in Andover, Massachusetts, USA.

This warranty does not apply to any equipment which has not been installed and used in accordance with the specifications recommended by **MKS** for the proper and normal use of the equipment. **MKS** shall not be liable under any circumstances for indirect, special, consequential, or incidental damages in connection with, or arising out of, the sale, performance, or use of the equipment covered by this warranty.

**MKS** recommends that all **MKS** pressure and flow products be calibrated periodically (typically every 6 to 12 months) to ensure accurate readings. When a product is returned to **MKS** for this periodic re-calibration it is considered normal preventative maintenance not covered by any warranty.

THIS WARRANTY IS IN LIEU OF ALL OTHER RELEVANT WARRANTIES, EXPRESSED OR IMPLIED, INCLUDING THE IMPLIED WARRANTY OF MERCHANTABILITY AND THE IMPLIED WARRANTY OF FITNESS FOR A PARTICULAR PURPOSE, AND ANY WARRANTY AGAINST INFRINGEMENT OF ANY PATENT.

120466-P1  
Rev B, 1/98

**MKS Type 670B  
High Accuracy  
Signal Conditioner**

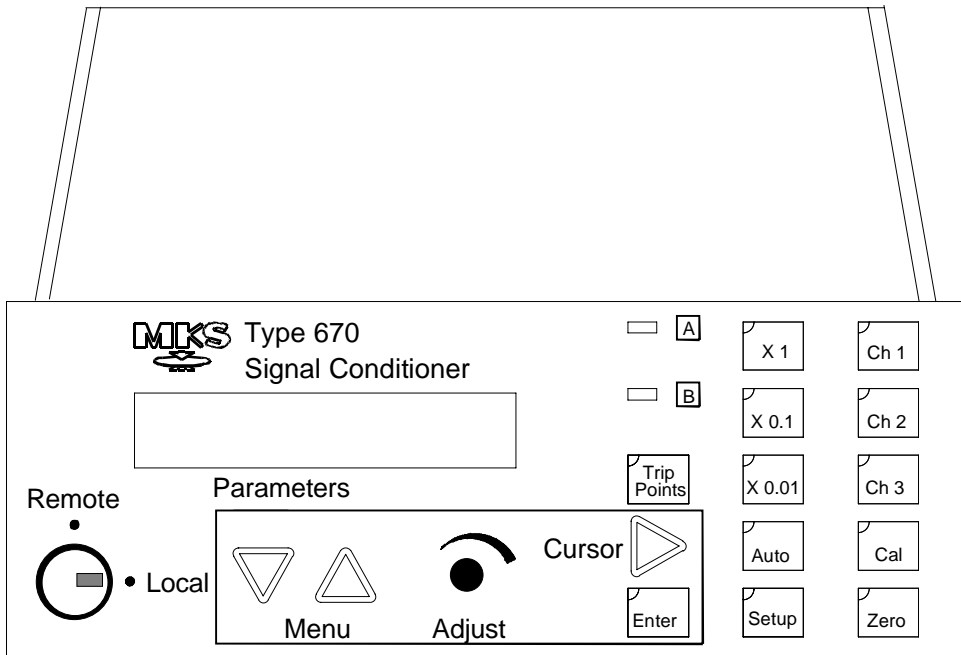

Copyright © 1998 by MKS Instruments, Inc.

All rights reserved. No part of this work may be reproduced or transmitted in any form or by any means, electronic or mechanical, including photocopying and recording, or by any information storage or retrieval system, except as may be expressly permitted in writing by MKS Instruments, Inc.

Printed in the United States of America

Baratron® is a registered trademark of MKS Instruments, Inc., Andover, MA

This manual is for firmware/software version 1.1x

## Table of Contents

Safety Information.....	1
Symbols Used in This Instruction Manual.....	1
Symbols Found on the Unit .....	2
Safety Procedures and Precautions .....	3
Sicherheitshinweise .....	5
In dieser Betriebsanleitung vorkommende Symbole .....	5
Am Gerät angebrachte Symbole.....	6
Sicherheitsvorschriften und Vorsichtsmaßnahmen.....	7
Informations relatives à la sécurité.....	9
Symboles utilisés dans ce manuel d'utilisation .....	9
Symboles apparaissant sur l'appareil .....	10
Mesures de sécurité et mises en garde .....	11
Información sobre seguridad.....	13
Símbolos usados en el manual de instrucciones.....	13
Símbolos que aparecen en la unidad.....	14
Procedimientos y precauciones de seguridad .....	15
Chapter One: General Information.....	17
Introduction .....	17
How This Manual is Organized.....	18
Manual Conventions .....	19
Customer Support.....	20
Chapter Two: Installation .....	21
How To Unpack the Type 670 Unit .....	21
Unpacking Checklist .....	21
Interface Cables .....	23
System Interface Cables .....	23
Remote Communications Interface Cables.....	24
Generic Shielded Cable Description .....	25

Example 1: Preferred Method To Connect Cable.....	26
Example 2: Alternate Method To Connect Cable .....	26
Product Location and Requirements .....	27
Operating Environmental Requirements.....	27
Safety Conditions .....	27
Electrical Requirements .....	27
Dimensions .....	28
Chapter Three: Hardware Overview .....	31
Front Panel.....	31
Key Lock Switch .....	31
Display Area.....	32
Trip Point LEDs .....	32
Range Selector Keys.....	32
Channel Selector Lights.....	32
Cursor Key .....	32
Adjust Knob .....	32
Arrow Keys .....	32
Rear Panel.....	33
Serial Interface or IEEE-488 Connector .....	34
I/O Connector .....	36
Pressure Output Signal.....	36
Signal Conditioner Board.....	38
Power Entry Module.....	40
Labels .....	41
Serial Number Label .....	41
Chapter Four: Functional Overview .....	43
General Information .....	43
Color Coded Keys .....	43
Scrolling.....	43
How To Change Entries.....	44
Display Screen.....	44
How To Change Channels .....	45

---

The [SETUP] Key.....	45
Display Size .....	45
Response.....	46
Heater .....	47
Pressure Units .....	48
Sensor Range .....	49
Temperature Compensation.....	50
Averaging .....	51
RS-232 Communication Parameters (Optional).....	53
IEEE-488 Communication Parameters (Optional).....	53
The [TRIP POINTS] Key.....	54
Trip Point Settings .....	54
Hysteresis.....	56
Relay State.....	57
Channel Selection.....	58
Latching a Trip Point.....	58
The [CAL] Key.....	60
Null.....	60
Full Scale .....	60
System Check Calibration .....	61
The [ZERO] Key .....	62
Zero Enable.....	62
Zero Calibration .....	62
The [AUTO] and Range Keys.....	64
Chapter Five: Operation .....	67
How To Configure the 670 Instrument.....	67
How To Interface to the Type 274 Multiplexer.....	69
Connecting the Cables.....	69
Configuring the 274 Multiplexer .....	70
Configuring the 670 Instrument.....	70
How To Set the Sensor Full Scale Entry .....	71
How To Calibrate the 670 Instrument .....	72
Additional Calibration for the Type 274 Multiplexer .....	74

How To Configure the Trip Points .....	75
How To Disable a Trip Point.....	77
How To Clear a Latched Trip Point.....	77
How To Adjust Hysteresis.....	78
How To Select the Range Setting Remotely .....	79
How To Use the Remote Zero Feature.....	80
How To Display the Software Version Number.....	81
How To Display the Heater Current with the Pressure Reading .....	81
How To Change the Line Voltage Selection .....	82
How To Use the SYSCHK Feature.....	83
<b>Chapter Six: RS-232 Communications Option .....</b>	<b>85</b>
General Information .....	85
Communication Parameters.....	85
RS-232 Protocol.....	86
Message Syntax .....	86
Commands.....	86
Requests .....	87
Responses.....	87
RS-232 Messages.....	89
Global Messages.....	90
Channel-Specific Messages.....	92
Trip Point Messages .....	96
Diagnostic Messages.....	98
<b>Chapter Seven: IEEE-488 Communications Option .....</b>	<b>103</b>
General Information .....	103
Key Lock Switch .....	103
IEEE-488 Device Compliance.....	104
Buffer Length .....	104
Address.....	104
Status Information.....	105
Standard Event Status Register .....	106
Status Byte Register.....	107

---

Generating a Service Request .....	108
IEEE-488 Messages .....	109
Clear Status Command (*CLS) .....	109
Operation Complete Messages.....	109
Wait-to-Continue Command (*WAI).....	109
Identification Query (*IDN?).....	110
Reset Command (*RST).....	110
Self-Test Query (*TST?) .....	110
MKS Device Dependent Messages.....	111
Command Syntax .....	111
Global Configuration Messages.....	112
Channel-Specific Messages .....	115
Trip Point Messages .....	121
Diagnostic Messages .....	124
Chapter Eight: Maintenance and Troubleshooting.....	127
General Information.....	127
How To Clean the Unit .....	127
How To Replace the Fuses.....	128
Troubleshooting.....	130
Troubleshooting Chart.....	132
Test A: Localizing Malfunction to the Cable or the Electronics Unit .....	133
Test B: Localizing Malfunctions to the Electronics Unit.....	136
Appendix A: Product Specifications .....	137
Performance Specifications .....	137
Physical Specifications .....	139
Environmental Specifications.....	140
Electrical Specifications.....	140
Appendix B: Model Code Explanation .....	141
Model Code .....	141
Appendix C: Initial Settings .....	143
General Information.....	143

Table of Contents

---

Appendix D: Interface Cables for a Type 274 Multiplexer.....	145
I/O Connector Cables .....	145
CB670-2 Y Cable .....	145
Index .....	149

---

## List of Figures

Figure 1: Preferred Method.....	26
Figure 2: Alternate Method To Use When Cable Clamp is Not Available.....	26
Figure 3: Front View Dimensions.....	28
Figure 4: Side View Dimensions .....	28
Figure 5: Top View Dimensions.....	29
Figure 6: The Front Panel.....	31
Figure 7: The Rear Panel with RS-232 Communications .....	33
Figure 8: The Rear Panel with IEEE-488 Communications.....	33
Figure 9: Labels on the Rear Panel .....	41
Figure 10: Serial Number Label.....	41
Figure 11: Averaging with 5 Data Points .....	51
Figure 12: Hysteresis Bands Applied to the Trip Point Values.....	56
Figure 13: Hysteresis Bands and Trip Point Values .....	56
Figure 14: Autoranging on a 10 Volt Full Scale Signal.....	64
Figure 15: Connecting to a Single Pressure Transducer .....	67
Figure 16: Connecting to a Type 274 Multiplexer.....	69
Figure 17: IEEE-488 Registers .....	105
Figure 18: Troubleshooting Flow Chart.....	132
Figure 19: Two Resistors Added to the Transducer Cable.....	134



## List of Tables

Table 1: Definition of Symbols Found on the Unit .....	2
Tabelle 2: Definitionen der am Gerät angebrachten Symbole .....	6
Tableau 3 : Définition des symboles apparaissant sur l'appareil .....	10
Tabla 4 : Definición de los símbolos que aparecen en la unidad .....	14
Table 5: System Interface Cables .....	23
Table 6: Interface Cables for Remote Communications .....	24
Table 7: Pinout of the Serial Interface Connector .....	34
Table 8: Pinout of the IEEE-488 Connector .....	35
Table 9: Pinout of the I/O Connector .....	37
Table 10: Pinout of the Head Connector on the Signal Conditioner Board .....	38
Table 11: Pinout of the Signal Connector on the Signal Conditioner Board .....	39
Table 12: Color Coding of Front Panel Keys .....	43
Table 13: Instrument Response Settings .....	46
Table 14: Optimal Averaging and Response Entries .....	52
Table 15: Action of the Trip Points .....	54
Table 16: Relationship Between Averaging Entry and Calibration Times .....	73
Table 17: Connections to Clear a Latch on the Trip Points .....	77
Table 18: Pin State for Remote Range Selection .....	79
Table 19: RS-232 Communication Parameters .....	85
Table 20: Responses for Rejected Commands .....	88
Table 21: RS-232 Global Messages .....	90
Table 22: RS-232 Channel-Specific Messages .....	92
Table 23: RS-232 Trip Point Messages .....	96
Table 24: RS-232 Diagnostic Messages .....	98
Table 25: I/O Connector Output Bit Assignment .....	99
Table 26: I/O Connector Input Bit Assignment .....	101
Table 27: IEEE-488 Device Compliance .....	104
Table 28: Standard Event Status Register .....	106
Table 29: Status Byte Register .....	107

Table 30: Commands for the Enable Registers .....	108
Table 31: Identification Query Response.....	110
Table 32: IEEE-488 Global Messages .....	112
Table 33: IEEE-488 Channel-Specific Messages.....	115
Table 34: IEEE-488 Trip Point Messages.....	121
Table 35: IEEE-488 Diagnostic Messages.....	124
Table 36: Fuses for the Type 670 Instrument .....	128
Table 37: Transducer Cable Voltage Check.....	134
Table 38: Electronics Unit Voltage Check.....	136
Table 39: Initial Settings.....	143
Table 40: Pinout of the Y-Cable 25-pin Male Connector.....	146
Table 41: Pinout of the Y-Cable 25-pin Female Connector .....	147

## Safety Information

### Symbols Used in This Instruction Manual

Definitions of WARNING, CAUTION, and NOTE messages used throughout the manual.

---

**Warning**  The **WARNING** sign denotes a hazard. It calls attention to a procedure, practice, condition, or the like, which, if not correctly performed or adhered to, could result in injury to personnel.

---

---

**Caution**  The **CAUTION** sign denotes a hazard. It calls attention to an operating procedure, practice, or the like, which, if not correctly performed or adhered to, could result in damage to or destruction of all or part of the product.

---

---

**Note**  The **NOTE** sign denotes important information. It calls attention to a procedure, practice, condition, or the like, which is essential to highlight.

---

## Symbols Found on the Unit

The following table describes symbols that may be found on the unit.















Definition of Symbols Found on the Unit			
			
On (Supply) IEC 417, No.5007	Off (Supply) IEC 417, No.5008	Earth (ground) IEC 417, No.5017	Protective earth (ground) IEC 417, No.5019
			
Frame or chassis IEC 417, No.5020	Equipotentiality IEC 417, No.5021	Direct current IEC 417, No.5031	Alternating current IEC 417, No.5032
			
Both direct and alternating current IEC 417, No.5033-a	Class II equipment IEC 417, No.5172-a	Three phase alternating current IEC 617-2 No.020206	
			
Caution, refer to accompanying documents ISO 3864, No.B.3.1	Caution, risk of electric shock ISO 3864, No.B.3.6	Caution, hot surface IEC 417, No.5041	

Table 1: Definition of Symbols Found on the Unit

## **Safety Procedures and Precautions**

**The following general safety precautions must be observed during all phases of operation of this instrument. Failure to comply with these precautions or with specific warnings elsewhere in this manual violates safety standards of intended use of the instrument and may impair the protection provided by the equipment. MKS Instruments, Inc. assumes no liability for the customer's failure to comply with these requirements.**

### **DO NOT SUBSTITUTE PARTS OR MODIFY INSTRUMENT**

Do not install substitute parts or perform any unauthorized modification to the instrument. Return the instrument to an MKS Calibration and Service Center for service and repair to ensure that all safety features are maintained.

### **SERVICE BY QUALIFIED PERSONNEL ONLY**

Operating personnel must not remove instrument covers. Component replacement and internal adjustments must be made by qualified service personnel only.

### **GROUNDING THE PRODUCT**

This product is grounded through the grounding conductor of the power cord. To avoid electrical shock, plug the power cord into a properly wired receptacle before connecting it to the product input or output terminals. A protective ground connection by way of the grounding conductor in the power cord is essential for safe operation.

### **DANGER ARISING FROM LOSS OF GROUND**

Upon loss of the protective-ground connection, all accessible conductive parts (including knobs and controls that may appear to be insulating) can render an electrical shock.

### **GROUND AND USE PROPER ELECTRICAL FITTINGS**

Dangerous voltages are contained within this instrument. All electrical fittings and cables must be of the type specified, and in good condition. All electrical fittings must be properly connected and grounded.

### **USE THE PROPER POWER CORD**

Use only a power cord that is in good condition and which meets the input power requirements specified in the manual.

Use only a detachable cord set with conductors that have a cross-sectional area equal to or greater than 0.75 mm<sup>2</sup>. The power cable should be approved by a qualified agency such as VDE, Semko, or SEV.

**USE THE PROPER POWER SOURCE**

This product is intended to operate from a power source that does not apply more voltage between the supply conductors, or between either of the supply conductors and ground, than that specified in the manual.

**USE THE PROPER FUSE**

Use only a fuse of the correct type, voltage rating, and current rating, as specified for your product.

**DO NOT OPERATE IN EXPLOSIVE ATMOSPHERES**

To avoid explosion, do not operate this product in an explosive environment unless it has been specifically certified for such operation.

**HIGH VOLTAGE DANGER**

High voltage is present in the cable, and in the sensor when the controller is turned on.

## Sicherheitshinweise

### In dieser Betriebsanleitung vorkommende Symbole

Definition der mit WARNUNG!, VORSICHT! und HINWEIS überschriebenen Abschnitte in dieser Betriebsanleitung.

#### Warnung!



---

Das Symbol **WARNUNG!** weist auf eine Gefahrenquelle hin. Es macht auf einen Arbeitsablauf, eine Arbeitsweise, einen Zustand oder eine sonstige Gegebenheit aufmerksam, deren unsachgemäße Ausführung bzw. ungenügende Berücksichtigung zu Körperverletzung führen kann.

---

#### Vorsicht!



---

Das Symbol **VORSICHT!** weist auf eine Gefahrenquelle hin. Es macht auf einen Bedienungsablauf, eine Arbeitsweise oder eine sonstige Gegebenheit aufmerksam, deren unsachgemäße Ausführung bzw. ungenügende Berücksichtigung zu einer Beschädigung oder Zerstörung des Produkts oder von Teilen des Produkts führen kann.

---

#### Hinweis



---

Das Symbol **HINWEIS** weist auf eine wichtige Mitteilung hin, die auf einen Arbeitsablauf, eine Arbeitsweise, einen Zustand oder eine sonstige Gegebenheit von besonderer Wichtigkeit aufmerksam macht.

---

## Am Gerät angebrachte Symbole

Der untenstehenden Tabelle sind die Bedeutungen der Symbole zu entnehmen, die an dem Gerät angebracht sind.















Definitionen der am Gerät angebrachten Symbole			
			
Ein (Netz) IEC 417, Nr. 5007	Aus (Netz) IEC 417, Nr. 5008	Erde IEC 417, Nr. 5017	Schutzleiter IEC 417, Nr. 5019
			
Rahmen oder Chassis IEC 417, Nr. 5020	Äquipotentialanschluß IEC 417, Nr. 5021	Gleichstrom IEC 417, Nr. 5031	Wechselstrom IEC 417, Nr. 5032
			
Wechselstrom und Gleichstrom IEC 417, Nr. 5033-a	Geräteklasse II IEC 417, Nr. 5172-a	Drehstrom IEC 617-2 Nr. 020206	
			
Vorsicht! Bitte Begleitdokumente lesen! ISO 3864, Nr. B.3.1	Vorsicht! Stromschlaggefahr! ISO 3864, Nr. B.3.6	Vorsicht! Heiße Fläche! IEC 417, Nr. 5041	

Tabelle 2: Definitionen der am Gerät angebrachten Symbole

## **Sicherheitsvorschriften und Vorsichtsmaßnahmen**

**Die untenstehenden allgemeinen Sicherheitsvorschriften sind bei allen Betriebsphasen dieses Instruments zu befolgen. Jede Mißachtung dieser Sicherheitsvorschriften oder sonstiger spezifischer Warnhinweise in dieser Betriebsanleitung stellt eine Zuwiderhandlung der für dieses Instrument geltenden Sicherheitsstandards dar und kann die an diesem Instrument vorgesehenen Schutzvorrichtungen unwirksam machen. MKS Instruments, Inc. haftet nicht für eine Mißachtung dieser Sicherheitsvorschriften seitens des Kunden.**

### **Keine Teile austauschen und keine Veränderungen vornehmen!**

Bauen Sie in das Instrument keine Ersatzteile ein, und nehmen Sie keine eigenmächtigen Änderungen am Gerät vor! Schicken Sie das Instrument zu Wartungs- und Reparaturzwecken an einen MKS-Kalibrierungs- und -Kundendienst ein! Dadurch wird sichergestellt, daß alle Sicherheitseinrichtungen voll funktionsfähig bleiben.

### **Wartung nur durch qualifizierte Fachleute!**

Das Gehäuse des Instruments darf vom Bedienpersonal nicht geöffnet werden. Das Auswechseln von Bauteilen und das Vornehmen von internen Einstellungen ist nur von qualifizierten Fachleuten durchzuführen.

### **Produkt erden!**

Dieses Produkt ist mit einer Erdleitung und einem Schutzkontakt am Netzstecker versehen. Um der Gefahr eines elektrischen Schlages vorzubeugen, ist das Netzkabel an einer vorschriftsmäßig geerdeten Schutzkontaktsteckdose anzuschließen, bevor es an den Eingangs- bzw. Ausgangsklemmen des Produkts angeschlossen wird. Das Instrument kann nur sicher betrieben werden, wenn es über den Erdleiter des Netzkabels und einen Schutzkontakt geerdet wird.

### **Gefährdung durch Verlust der Schutzerdung!**

Geht die Verbindung zum Schutzleiter verloren, besteht an sämtlichen zugänglichen Teilen aus stromleitendem Material die Gefahr eines elektrischen Schlages. Dies gilt auch für Knöpfe und andere Bedienelemente, die dem Anschein nach isoliert sind.

**Erdung und Verwendung geeigneter elektrischer Armaturen!**

In diesem Instrument liegen gefährliche Spannungen an. Alle verwendeten elektrischen Armaturen und Kabel müssen dem angegebenen Typ entsprechen und sich in einwand-freiem Zustand befinden. Alle elektrischen Armaturen sind vorschriftsmäßig anzubringen und zu erden.

**Richtiges Netzkabel verwenden!**

Das verwendete Netzkabel muß sich in einwandfreiem Zustand befinden und den in der Betriebsanleitung enthaltenen Anschlußwerten entsprechen.

Das Netzkabel muß abnehmbar sein. Der Querschnitt der einzelnen Leiter darf nicht weniger als  $0,75 \text{ mm}^2$  betragen. Das Netzkabel sollte einen Prüfvermerk einer zuständigen Prüfstelle tragen, z.B. VDE, Semko oder SEV.

**Richtige Stromquelle verwenden!**

Dieses Produkt ist für eine Stromquelle vorgesehen, bei der die zwischen den Leitern bzw. zwischen jedem der Leiter und dem Masseleiter anliegende Spannung den in dieser Betriebsanleitung angegebenen Wert nicht überschreitet.

**Richtige Sicherung benutzen!**

Es ist eine Sicherung zu verwenden, deren Typ, Nennspannung und Nennstromstärke den Angaben für dieses Produkt entsprechen.

**Gerät nicht in explosiver Atmosphäre benutzen!**

Um der Gefahr einer Explosion vorzubeugen, darf dieses Gerät nicht in der Nähe explosiver Stoffe eingesetzt werden, sofern es nicht ausdrücklich für diesen Zweck zertifiziert worden ist.

**Hochspannungsgefahr!**

Bei eingeschaltetem Steuerteil liegt im Kabel und im Sensor Hochspannung an.

## Informations relatives à la sécurité

### Symboles utilisés dans ce manuel d'utilisation

Définition des indications AVERTISSEMENT, ATTENTION et REMARQUE utilisées dans ce manuel.

Avertissement



---

L'indication AVERTISSEMENT signale un danger potentiel. Elle est destinée à attirer l'attention sur une procédure, une utilisation, une situation ou toute autre chose présentant un risque de blessure en cas d'exécution incorrecte ou de non-respect des consignes.

---

Attention



---

L'indication ATTENTION signale un danger potentiel. Elle est destinée à attirer l'attention sur une procédure, une utilisation, une situation ou toute autre chose présentant un risque d'endommagement ou de dégât d'une partie ou de la totalité de l'appareil en cas d'exécution incorrecte ou de non-respect des consignes.

---

Remarque



---

L'indication REMARQUE signale des informations importantes. Elle est destinée à attirer l'attention sur une procédure, une utilisation, une situation ou toute autre chose présentant un intérêt particulier.

---

## Symboles apparaissant sur l'appareil

Le tableau suivant décrit les symboles apparaissant sur l'appareil.















Définition des symboles apparaissant sur l'appareil			
			
Marche (sous tension) IEC 417, No. 5007	Arrêt (hors tension) IEC 417, No. 5008	Terre (masse) IEC 417, No. 5017	Terre de protection (masse) IEC 417, No. 5019
			
Masse IEC 417, No. 5020	Equipotentialité IEC 417, No. 5021	Courant continu IEC 417, No. 5031	Courant alternatif IEC 417, No. 5032
			
Courant continu et alternatif IEC 417, No. 5033-a	Matériel de classe II IEC 417, No. 5172-a	Courant alternatif triphase IEC 617-2 No. 020206	
			
Attention : se reporter à la documentation ISO 3864, No. B.3.1	Attention : risque de secousse électrique ISO 3864, No. B.3.6	Attention : surface brûlante IEC 417, No. 5041	

Tableau 3 : Définition des symboles apparaissant sur l'appareil

## **Mesures de sécurité et mises en garde**

**Prendre toutes les précautions générales suivantes pendant toutes les phases d'utilisation de cet appareil. Le non-respect de ces précautions ou des avertissements contenus dans ce manuel entraîne une violation des normes de sécurité relatives à l'utilisation de l'appareil et le risque de réduire le niveau de protection fourni par l'appareil. MKS Instruments, Inc. ne prend aucune responsabilité pour les conséquences de tout non-respect des consignes de la part de ses clients.**

### **NE PAS SUBSTITUER DES PIÈCES OU MODIFIER L'APPAREIL**

Ne pas utiliser de pièces détachées autres que celles vendues par MKS Instruments, Inc. ou modifier l'appareil sans l'autorisation préalable de MKS Instruments, Inc. Renvoyer l'appareil à un centre d'étalonnage et de dépannage MKS pour tout dépannage ou réparation afin de s'assurer que tous les dispositifs de sécurité sont maintenus.

### **DÉPANNAGE EFFECTUÉ UNIQUEMENT PAR UN PERSONNEL QUALIFIÉ**

L'opérateur de l'appareil ne doit pas enlever le capot de l'appareil. Le remplacement des composants et les réglages internes doivent être effectués uniquement par un personnel d'entretien qualifié.

### **MISE À LA TERRE DE L'APPAREIL**

Cet appareil est mis à la terre à l'aide du fil de terre du cordon d'alimentation. Pour éviter tout risque de secousse électrique, brancher le cordon d'alimentation sur une prise de courant correctement câblée avant de le brancher sur les bornes d'entrée ou de sortie de l'appareil. Une mise à la terre de protection à l'aide du fil de terre du cordon d'alimentation est indispensable pour une utilisation sans danger de l'appareil.

### **DANGER LIÉ À UN DÉFAUT DE TERRE**

En cas de défaut de terre, toutes les pièces conductrices accessibles (y compris les boutons de commande ou de réglage qui semblent être isolés) peuvent être source d'une secousse électrique.

### **MISE À LA TERRE ET UTILISATION CORRECTE D'ACCESSOIRES ÉLECTRIQUES**

Des tensions dangereuses existent à l'intérieur de l'appareil. Tous les accessoires et les câbles électriques doivent être conformes au type spécifié et être en bon état. Tous les accessoires électriques doivent être correctement connectés et mis à la terre.

**UTILISATION D'UN CORDON D'ALIMENTATION APPROPRIÉ**

Utiliser uniquement un cordon d'alimentation en bon état et conforme aux exigences de puissance d'entrée spécifiées dans le manuel.

Utiliser uniquement un cordon d'alimentation amovible avec des conducteurs dont la section est égale ou supérieure à 0,75 mm<sup>2</sup>. Le cordon d'alimentation doit être approuvé par un organisme compétent tel que VDE, Semko ou SEV.

**UTILISATION D'UNE ALIMENTATION APPROPRIÉE**

Cet appareil est conçu pour fonctionner en s'alimentant sur une source de courant électrique n'appliquant pas une tension entre les conducteurs d'alimentation, ou entre les conducteurs d'alimentation et le conducteur de terre, supérieure à celle spécifiée dans le manuel.

**UTILISATION D'UN FUSIBLE APPROPRIÉ**

Utiliser uniquement un fusible conforme au type, à la tension nominale et au courant nominal spécifiés pour l'appareil.

**NE PAS UTILISER DANS UNE ATMOSPHÈRE EXPLOSIVE**

Pour éviter tout risque d'explosion, ne pas utiliser l'appareil dans une atmosphère explosive à moins qu'il n'ait été approuvé pour une telle utilisation.



**DANGER DE HAUTE TENSION**

Une haute tension est présente dans le câble et dans le capteur lorsque le contrôleur est sous tension.

## Información sobre seguridad

### Símbolos usados en el manual de instrucciones

Definiciones de los mensajes de ADVERTENCIA, PRECAUCIÓN Y OBSERVACIÓN usados en el manual.

Advertencia		El símbolo de ADVERTENCIA indica un riesgo. <b>Pone de relieve un procedimiento, práctica, condición, etc., que, de no realizarse u observarse correctamente, podría causar lesiones a los empleados.</b>
Precaución		El símbolo de PRECAUCIÓN indica un riesgo. <b>Pone de relieve un procedimiento, práctica, etc., de tipo operativo que, de no realizarse u observarse correctamente, podría causar desperfectos al instrumento, o llegar incluso a causar su destrucción total o parcial.</b>
Observación		El símbolo de OBSERVACIÓN indica información de importancia. <b>Pone de relieve un procedimiento, práctica, condición, etc., cuyo conocimiento resulta esencial.</b>

## Símbolos que aparecen en la unidad

En la tabla que figura a continuación se indican los símbolos que aparecen en la unidad.















Definición de los símbolos que aparecen en la unidad			
 Encendido (alimentación eléctrica) IEC 417, N.º 5007	 Apagado (alimentación eléctrica) IEC 417, N.º 5008	 Puesta a tierra IEC 417, N.º 5017	 Protección a tierra IEC 417, N.º 5019
 Caja o chasis IEC 417, N.º 5020	 Equipotencialidad IEC 417, N.º 5021	 Corriente continua IEC 417, N.º 5031	 Corriente alterna IEC 417, N.º 5032
 Corriente continua y alterna IEC 417, N.º 5033-a	 Equipo de clase II IEC 417, N.º 5172-a	 Corriente alterna trifásica IEC 617-2 N.º 020206	
 Precaución. Consultar los documentos adjuntos ISO 3864, N.º B.3.1	 Precaución. Riesgo de descarga eléctrica ISO 3864, N.º B.3.6	 Precaución. Superficie caliente IEC 417, N.º 5041	

Tabla 4 : Definición de los símbolos que aparecen en la unidad

## **Procedimientos y precauciones de seguridad**

**Las precauciones generales de seguridad que figuran a continuación deben observarse durante todas las fases de funcionamiento del presente instrumento. La no observancia de dichas precauciones, o de las advertencias específicas a las que se hace referencia en el manual, contraviene las normas de seguridad referentes al uso previsto del instrumento y podría impedir la protección que proporciona el instrumento. MKS Instruments, Inc., no asume responsabilidad alguna en caso de que el cliente haga caso omiso de estos requerimientos.**

### **NO UTILIZAR PIEZAS NO ORIGINALES NI MODIFICAR EL INSTRUMENTO**

No se debe instalar piezas que no sean originales ni modificar el instrumento sin autorización. Para garantizar que las prestaciones de seguridad se observen en todo momento, enviar el instrumento al Centro de servicio y calibración de MKS cuando sea necesaria su reparación y servicio de mantenimiento.

### **REPARACIONES EFECTUADAS ÚNICAMENTE POR TÉCNICOS ESPECIALIZADOS**

Los operarios no deben retirar las cubiertas del instrumento. El cambio de piezas y los reajustes internos deben efectuarlos únicamente técnicos especializados.

### **PUESTA A TIERRA DEL INSTRUMENTO**

Este instrumento está puesto a tierra por medio del conductor de tierra del cable eléctrico. Para evitar descargas eléctricas, enchufar el cable eléctrico en una toma debidamente instalada, antes de conectarlo a las terminales de entrada o salida del instrumento. Para garantizar el uso sin riesgos del instrumento resulta esencial que se encuentre puesto a tierra por medio del conductor de tierra del cable eléctrico.

### **PELIGRO POR PÉRDIDA DE LA PUESTA A TIERRA**

Si se pierde la conexión protectora de puesta a tierra, todas las piezas conductoras a las que se tiene acceso (incluidos los botones y mandos que pudieran parecer estar aislados) podrían producir descargas eléctricas.

### **PUESTA A TIERRA Y USO DE ACCESORIOS ELÉCTRICOS ADECUADOS**

Este instrumento funciona con voltajes peligrosos. Todos los accesorios y cables eléctricos deben ser del tipo especificado y mantenerse en buenas condiciones. Todos los accesorios eléctricos deben estar conectados y puestos a tierra del modo adecuado.

**USAR EL CABLE ELÉCTRICO ADECUADO**

Usar únicamente un cable eléctrico que se encuentre en buenas condiciones y que cumpla los requisitos de alimentación de entrada indicados en el manual.

Usar únicamente un cable desmontable instalado con conductores que tengan un área de sección transversal equivalente o superior a 0,75mm<sup>2</sup>. El cable eléctrico debe estar aprobado por una entidad autorizada como, por ejemplo, VDE, Semko o SEV.

**USAR LA FUENTE DE ALIMENTACIÓN ELÉCTRICA ADECUADA**

Este instrumento debe funcionar a partir de una fuente de alimentación eléctrica que no aplique más voltaje entre los conductores de suministro, o entre uno de los conductores de suministro y la puesta a tierra, que el que se especifica en el manual.

**USAR EL FUSIBLE ADECUADO**

Usar únicamente un fusible del tipo, clase de voltaje y de corriente adecuados, según lo que se especifica para el instrumento.

**EVITAR SU USO EN ENTORNOS EXPLOSIVOS**

Para evitar el riesgo de explosión, no usar este instrumento o en un entorno explosivo, a no ser que haya sido certificado para tal uso.

**PELIGRO POR ALTO VOLTAJE**

Cuando el controlador está encendido, se registra alto voltaje en el cable y en el sensor.

## Chapter One: General Information

### Introduction

The MKS Type 670B High Accuracy Signal Conditioner is designed to work with the MKS 300 and 600 Series Baratron<sup>®</sup> high accuracy pressure transducers. The 670 instrument consists of the power supplies, heater control, and oscillator necessary to interface with the compatible MKS pressure transducers. When combined with the Type 274 multiplexer, the 670 instrument can measure the pressure from up to three pressure transducers (from either the 300 or 600 Series, or a combination of both). The front panel includes three channel selector keys, each with a light in the upper left hand corner that illuminates when the channel is selected to visually indicate the active channel. The display screen can list the pressure reading as a 3½, 4½ or 5½ digit number. The unit is designed to fit in the standard ½ rack mount.

You can control the 670 instrument remotely, using either RS-232C or IEEE-488 (IEEE-488.2) communications. Both methods of remote communication allow you to perform virtually all the functions available through the front panel. While operating in the REMOTE mode, the instrument expects to receive commands through the RS-232 port, the IEEE-488 bus, or the rear panel connectors, so it locks out any commands entered through the front panel. This eliminates the possibility of accidental command entries. In LOCAL mode the instrument accepts commands issued by using the front panel only. During LOCAL mode operation, the RS-232 port and the IEEE-488 bus can be used to report status information. Remote communication commands to change operating parameters will not be accepted while in LOCAL mode.

The 670 instrument contains two alarm trip points. The high and low values for each trip point define a “normal” operating range for the pressure signal. If the pressure signal deviates from the range defined by the trip points, a trip point becomes activated and causes a relay to change state. The adjustable hysteresis feature prevents any “relay chatter” because it defines a deadband around each trip point. This deadband provides a “margin of error” since the relay does not change state until the pressure signal exceeds, or drops below, the trip point setting *plus* the hysteresis value. Therefore, an alarm condition does not occur if the pressure signal hovers around the trip point. In addition, you define the normal state for each relay as either energized or de-energized.

The averaging feature of the 670 instrument reduces fluctuation in the pressure reading by averaging multiple readings. This is especially useful in systems where the pressure is unstable. Instead of displaying every data point, the 670 instrument can average incoming data points with a specified number of data points collected previously. The display shows the averaged value, rather than the actual new data point. This averaging acts to smooth out the pressure readings. The number of points to average can range from 1 and 99, inclusive.

## How This Manual is Organized

This manual provides instructions on how to set up, install, and operate a 670 unit.

**Before installing your Type 670 unit in a system and/or operating it, carefully read and familiarize yourself with all precautionary notes in the *Safety Messages and Procedures* section at the front of this manual. In addition, observe and obey all WARNING and CAUTION notes provided throughout the manual.**

Chapter One, *General Information*, (this chapter) introduces the product and describes the organization of the manual.

Chapter Two, *Installation*, explains the environmental requirements and describes how to mount the instrument in your system.

Chapter Three, *Hardware Overview*, gives a brief description of the instrument and its functionality.

Chapter Four, *Functional Overview*, outlines the software features and functions.

Chapter Five, *Operation*, describes how to use the Type 670 instrument and explains all its functions and features.

Chapter Six, *RS-232 Communications Option*, discusses the optional RS-232C communications.

Chapter Seven, *IEEE-488 Communications Option*, describes the optional IEEE-488 syntax and messages.

Chapter Eight, *Maintenance and Troubleshooting*, provides a checklist for reference in the event your instrument malfunctions.

Appendix A, *Product Specifications*, lists the specifications for the instrument.

Appendix B, *Initial Settings*, lists the initial settings for the instrument.

Appendix C, *Sample BASIC Programs*, provides several short BASIC programs written for the IEEE-488 communications option.

Appendix D, *Interface Cables for a Type 274 Multiplexer*, lists the pinout of the Y-cable.

## Manual Conventions

The following conventions apply throughout this manual:

<u>XXXXXX</u> <i>For inputs:</i>	Indicates that the line must be pulled low to activate the function.
<u>XXXXXX</u> <i>For outputs:</i>	Indicates that the output is active low.
<b>670 Front Panel Keys:</b>	Keys on the front panel of the 670 instrument appear in square brackets with leading spaces, for example, Press the [ENTER] key.
<b>Operating Mode</b>	The operating mode appears in small capital letters, such as LOCAL mode
<b>Knobs or Switches on the 274:</b>	Knobs and switches on the 274 multiplexer appear in small capital letters with leading spaces, for example: Set the CHANNEL SELECT switch in the REM position.

## **Customer Support**

Standard maintenance and repair services are available at all of our regional MKS Calibration and Service Centers listed on the back cover. In addition, MKS accepts the instruments of other manufacturers for recalibration using the Primary and Transfer Standard calibration equipment located at all of our regional service centers. Should any difficulties arise in the use of your Type 670 instrument, or to obtain information about companion products MKS offers, contact any authorized MKS Calibration and Service Center. If it is necessary to return the instrument to MKS, please obtain an ERA Number (Equipment Return Authorization Number) from the MKS Calibration and Service Center before shipping. The ERA Number expedites handling and ensures proper servicing of your instrument.

Please refer to the inside of the back cover of this manual for a list of MKS Calibration and Service Centers.

---

**Warning**

---

**All returns to MKS Instruments must be free of harmful, corrosive, radioactive, or toxic materials.**

---

Your 670 instrument can be calibrated with or without the pressure transducer. If you are using your 670 instrument with a high accuracy pressure transducer, and the units require calibration, you may wish to return both units to MKS. Calibrating the units together ensures the best possible accuracy.

## Chapter Two: Installation

### How To Unpack the Type 670 Unit

MKS has carefully packed the Type 670 unit so that it will reach you in perfect operating order. Upon receiving the unit, however, you should check for defects, cracks, broken connectors, etc., to be certain that damage has not occurred during shipment.

---

**Note**

Do *not* discard any packing materials until you have completed your inspection and are sure the unit arrived safely.

---

If you find any damage, notify your carrier and MKS immediately. If it is necessary to return the unit to MKS, obtain an ERA Number (Equipment Return Authorization Number) from the MKS Service Center before shipping. Please refer to the inside of the back cover of this manual for a list of MKS Calibration and Service Centers.

### Unpacking Checklist

---

**Caution**

**Only qualified individuals should perform the installation and any user adjustments. They must comply with all the necessary ESD and handling precautions while installing and adjusting the instrument. Proper handling is essential when working with all highly sensitive precision electronic instruments.**

---

The Type 670 unit includes the following standard parts plus any optional accessories ordered.

#### *Standard Equipment*

- The Type 670 instrument with either RS-232 or IEEE-488 remote communications
- A power cord
- Type 670 Instruction Manual (this book)
- Key for the Key Lock switch on the front panel

***Optional Equipment***

- 670B-K1 Electrical Connector Accessories Kit (includes mating connectors for all the electrical connectors)
- CB270-2-x (where x is the cable length in ft.) cable to connect the pressure transducer to the 670 instrument
- Serial Interface Cable to communicate with a computer equipped with RS-232 software  
Refer to Table 6, page 24, for a description of RS-232 cables.
- IEEE-488 cable to connect the 670 unit to a computer equipped with IEEE-488 software  
Refer to Table 6, page 24, for a description of IEEE-488 cables available.
- RM-6 Rack Mount to mount the 670 unit in a full 19" rack

***Cabling for use with a 274 multiplexer***

- Additional CB270-2-x (where x is the cable length in ft.) cables for each transducer (plus one to connect the 670 to the 274 unit)
- CB670-1 or CB670-2 cable to connect the 670 instrument to a 274 multiplexer (use the CB670-2 if you need to access the trip point relays and latching, remote zero, or remote range select)

**600 Series High Accuracy Baratron transducers:**

- 698 Differential Transducer (regulated at 45° C)
- 690 Absolute Transducer (regulated at 45° C)
- 617 Bakeable Absolute Transducer
- 616 Bakeable Differential Transducer
- 615 Bakeable Absolute Transducer
- 590 Absolute Transducer (regulated at 70° C)

**300 Series High Accuracy Baratron transducers:**

- 398 Differential Transducer
- 391 Differential Transducer
- 390 Absolute Transducer
- 370 Absolute or Differential Transducer
- 317 Bakeable Absolute Transducer
- 315 Bakeable Absolute or Differential Transducer
- 310 Absolute or Differential Transducer

The full scale range of the pressure transducers can vary from 0.1 to 25K Torr.

## Interface Cables

*As of January 1, 1996, most products shipped to the European Community must comply with the EMC Directive 89/336/EEC, which covers radio frequency emissions and immunity tests. In addition, as of January 1, 1997, most products shipped to the European Community must also comply with the Product Safety Directive 92/59/EEC and the Low-Voltage Directive 73/23/EEC, which cover general safety practices for design and workmanship. MKS products that meet these requirements are identified by application of the CE Mark.*

This MKS product meets CE requirements, per EMC Directive 89/336/EEC. To ensure compliance when installed, an overall metal braided shielded cable, grounded at both ends, is required during use. No additional installation requirements exist to ensure compliance with Directives 92/59/EEC and 73/23/EEC.

### Note



1. An overall metal braided shielded cable, properly grounded at both ends, is required during use to meet CE specifications.
2. To order a metal braided shielded cable, add an “S” after the cable type designation. For example, to order a standard connection cable, for a 690 transducer, use part number CB270-2 for a metal, braided, shielded cable use part number CB270S-2.

### System Interface Cables

The system interface cables include cables to connect the 670 unit to a transducer or to a Type 274 multiplexer unit which, in turn, can connect to a maximum of three transducers.

<b>System Interface Cables</b>	
<b>To Connect the 670 Unit To . . .</b>	<b>Use the MKS Cable . . .</b>
615, 616 or 617 transducer	CB270S-1- <i>x</i> or CB270-1- <i>x</i>
590, 690, or 698 transducer	or CB270S-2- <i>x</i> CB270-2- <i>x</i>
274 multiplexer	either a CB670-1/CB670S-1 or CB670-2/CB670S-2 (if you need to access the trip point relays and latching, remote zero, or remote range select)
274 to transducer(s)	CB270-2- <i>x</i>
<i>x</i> indicates the cable length in feet	

Table 5: System Interface Cables

### Remote Communications Interface Cables

Table 6 lists the cables to connect your 670 unit to either an RS-232 or IEEE-488 device.

<b>Interface Cables for Remote Communications</b>		
<b>Communication</b>	<b>Cable</b>	<b>Description</b>
RS-232	CB146-2-10	IBM compatible (9-pin female to 9-pin female), 10 ft
	CB146-4	25-pin adapter (25-pin female to 9-pin male)
IEEE-488	CB288-4-3	IEEE-488 cable, 1 meter length
	CB288-4-7	IEEE-488 cable, 2 meter length
	CB288-4-10	IEEE-488 cable, 3 meter length
	CB288-4-13	IEEE-488 cable, 4 meter length

Table 6: Interface Cables for Remote Communications

### Generic Shielded Cable Description

MKS offers a full line of cables for all MKS equipment. Should you choose to manufacture your own cables, follow the guidelines listed below:

1. The cable must have a *braided* shield, covering all wires. Neither aluminum foil nor spiral shielding will be as effective; using either may nullify regulatory compliance.
2. The connectors must have a metal case which has direct contact to the cable's shield on the whole circumference of the cable. The inductance of a flying lead or wire from the shield to the connector will seriously degrade the shield's effectiveness. The shield should be grounded to the connector before its internal wires exit.
3. With very few exceptions, the connector(s) must make good contact to the device's case (ground). "Good contact" is about 0.01 ohms; and the ground should surround all wires. Contact to ground at just one point may not suffice.
4. For shielded cables with flying leads at one or both ends; it is important at each such end, to ground the shield *before* the wires exit. Make this ground with absolute minimum length. Refer to Figures 1 and 2, page 26. (A ¼ inch piece of #22 wire may be undesirably long since it has approximately 5 nH of inductance, equivalent to 31 ohms at 1000 MHz). After picking up the braid's ground, keep wires and braid flat against the case. With very few exceptions, grounded metal covers are not required over terminal strips. If one is required, it will be stated in the instruction manual.
5. In selecting the appropriate type and wire size for cables, consider:
  - A. The voltage ratings.
  - B. The cumulative  $I^2R$  heating of all the conductors (keep them safely cool).
  - C. The IR drop of the conductors, so that adequate power or signal voltage gets to the device.
  - D. The capacitance and inductance of cables which are handling fast signals, (such as data lines or stepper motor drive cables).
  - E. That some cables may need internal shielding from specific wires to others; please see the instruction manual for details regarding this matter.

**Example 1: Preferred Method To Connect Cable**

*(shown on a transducer)*

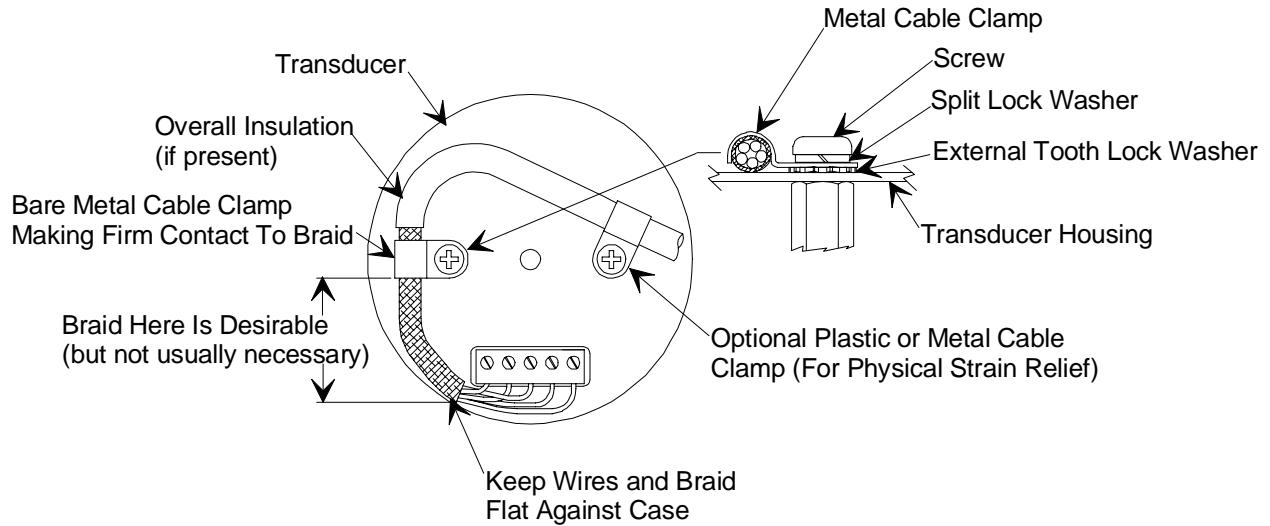

Figure 1: Preferred Method

**Example 2: Alternate Method To Connect Cable**

*(shown on a transducer)*

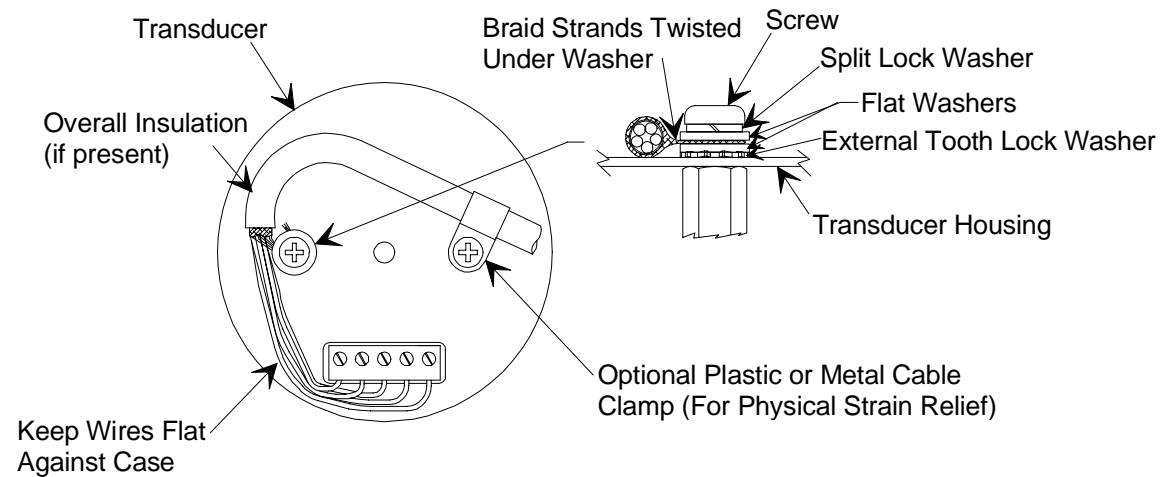

Figure 2: Alternate Method To Use When Cable Clamp is Not Available

## **Product Location and Requirements**

The Type 670 unit meets the following criteria:

- POLLUTION DEGREE 2 in accordance with IEC 664
- Transient overvoltages according to INSTALLATION CATEGORY II

### **Operating Environmental Requirements**

- Ambient Operating Temperature: 15° to 40° C (59° to 104° F)
- Main supply voltage fluctuations must not exceed  $\pm 10\%$  of the nominal voltage
- Connect the power cord into a grounded outlet
- Ventilation requirements include sufficient air circulation

#### **Caution**



---

**Position the 670 instrument in a location with sufficient air circulation. Insufficient air circulation could damage the instrument.**

---

### **Safety Conditions**

The 670 unit poses no safety risk under the following environmental conditions.

- Altitude: up to 2000 m
- Maximum relative humidity: 80% for temperatures up to 31 °C, decreasing linearly to 50% at 40 °C

The 670 instrument fits in a standard ½ rack mount and can be placed on a work bench or mounted in an instrument panel. The optional RM-6 Rack Mount is necessary to mount the controller in a panel cutout or a 19” rack.

### **Electrical Requirements**

- Power: 100 to 120 VAC nominal (for the 115 V line voltage setting) or 200 to 240 VAC nominal (for the 230 V line voltage setting) @ 50/60 Hz, 40 Watts (21 Watts with transducer heater off)

#### **Caution**



---

**Plug the 670 unit into a grounded electrical outlet to ensure proper grounding.**

---

## Dimensions

**Note**



All dimensions are listed in inches with millimeters referenced in parentheses.

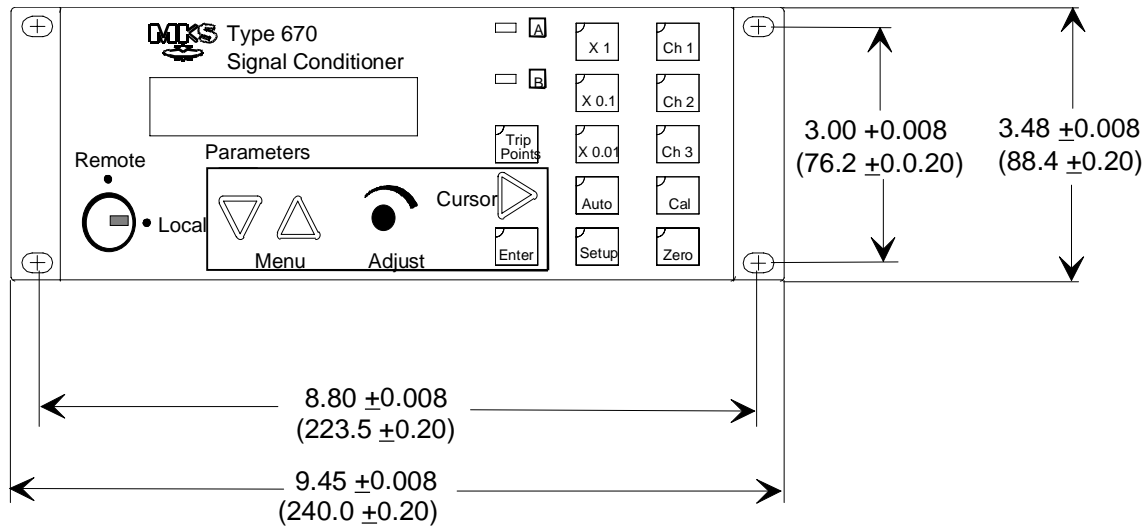

Figure 3: Front View Dimensions

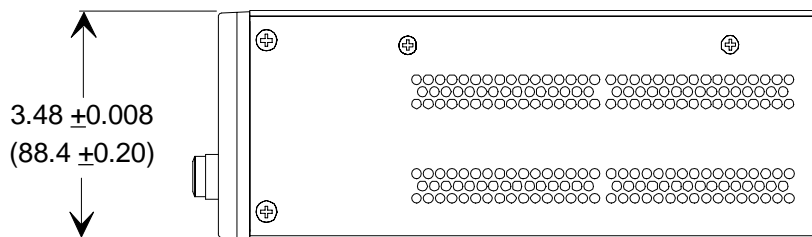

Figure 4: Side View Dimensions

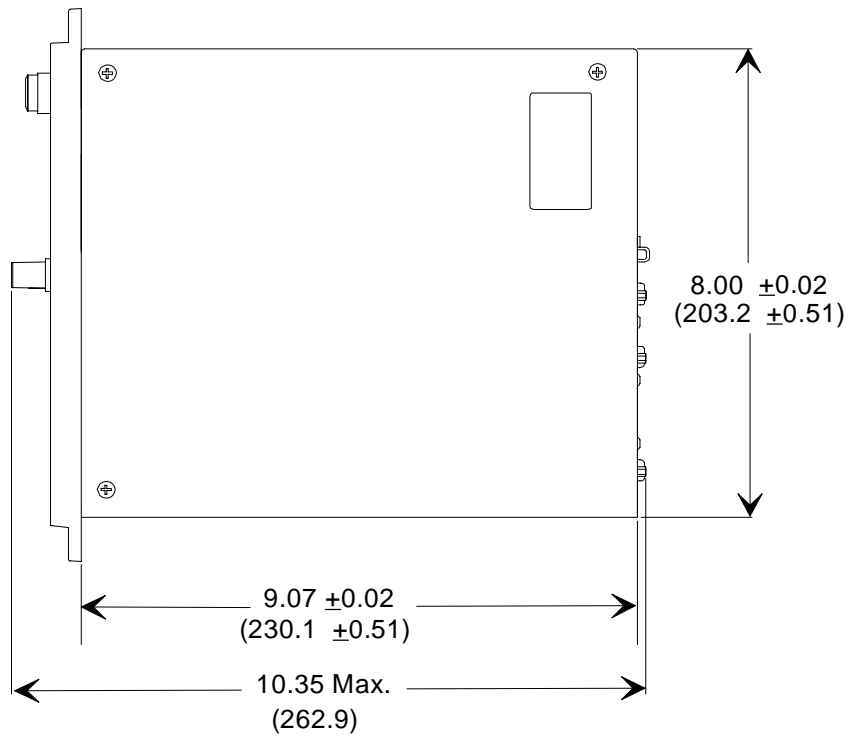

Figure 5: Top View Dimensions

This page intentionally left blank.

## Chapter Three: Hardware Overview

### Front Panel

Figure 6 shows the front panel of the 670 instrument. *Chapter Four: Functional Overview*, page 43, discusses the operation of the 670 instrument.

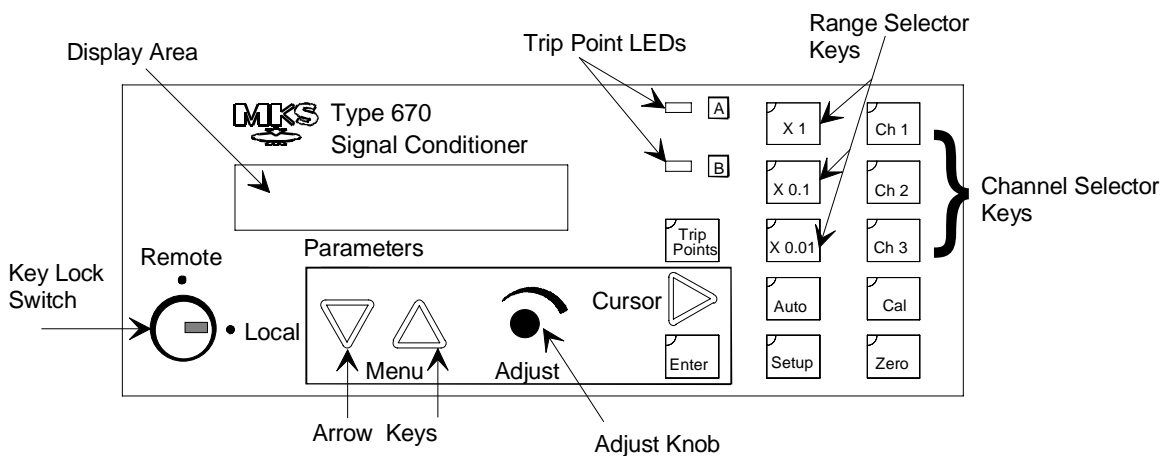

Figure 6: The Front Panel

### Key Lock Switch

The position of the Key Lock switch determines whether the 670 instrument operates under front panel (Local) or remote communications (either RS-232 or IEEE-488; and TTL logic) control. When the Key Lock switch is in the LOCAL position, the 670 instrument responds to commands entered through the front panel. It will respond to status requests only, not commands, sent through remote communications. Additionally, it will not accept TTL commands issued to the rear panel connectors. When the Key Lock switch is in the REMOTE position, the 670 instrument responds to commands sent to it through the serial port, the IEEE-488 bus, or the rear panel connectors. The front panel can display status information only — it cannot be used to enter commands. The front panel controls are locked as a safety measure to prevent accidental command entries.

The key can be removed from the unit when positioned in the REMOTE position. It cannot be removed when positioned in the LOCAL position.

## Display Area

The display area displays the pressure reading. It can also display the software version and the percentage of power supplied to a transducer heater. Additionally, when you press a mode key ( [SETUP] [CAL] or [ZERO] ) or the [TRIP POINTS] key, the display area changes to list the menu entries.

## Trip Point LEDs

The trip point LEDs illuminate when the pressure reading deviates from the region defined by the trip point high and low entries. The LEDs are extinguished when the pressure reading is within the boundaries defined by the trip points.

## Range Selector Keys

The 670 instrument uses the following ranges: x1, x0.1, x0.01, or autoranging. (This selection effects the displayed value, the value reported by remote communications, and the pressure output signal.) A small green light in the upper left-hand corner of the range key illuminates to indicate the active range. Both the AUTO key and the active range key illuminate while operating in the autoranging mode.

For more information, refer *The [AUTO] and Range Key*, page 64.

## Channel Selector Lights

The channel selector lights illuminate to indicate the selected channel. When the 670 instrument is connected to a single transducer, “Ch 1” is always illuminated, and neither front nor rear panel commands to change the channel will be accepted. When the 670 instrument is connected to a 274 multiplexer, data from up to three channels can be displayed individually. Simply push the appropriate channel key to select the active channel.



## Cursor Key

The [CURSOR] key is only active in menus that require you to enter a numeric value. Pressing the [CURSOR] key moves the blinking cursor from left to right on the screen. Once the blinking cursor reaches the rightmost digit and you press the [CURSOR] again, the blinking cursor will return to the leftmost digit.

## Adjust Knob

The Adjust knob is only active in menus where you must select the entry from a list of choices. Turning the Adjust knob scrolls through any options available for entries that contain lists, or it scrolls through numbers for numeric entries.

## Arrow Keys

The arrow keys (  and  ) allow you to scroll through the menu screens. The arrow keys have no function when the 670 instrument is not in a menu.

## Rear Panel

Figure 7 shows the rear panel of the 670 instrument.

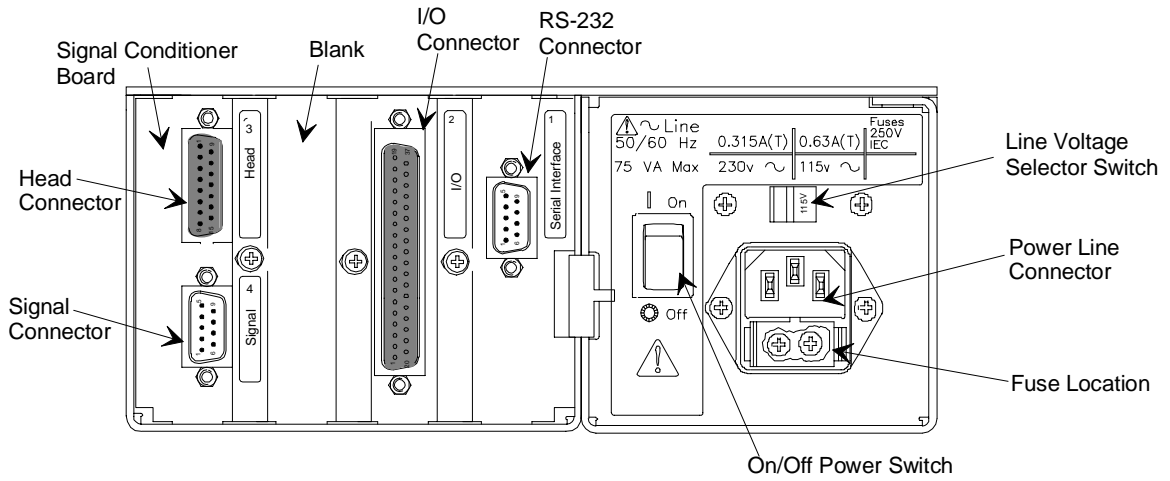

Figure 7: The Rear Panel with RS-232 Communications

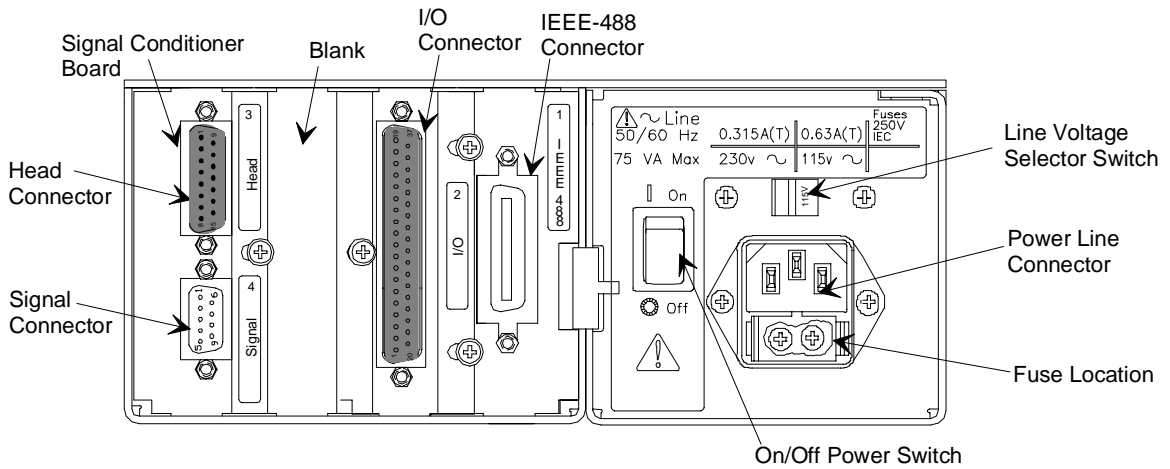

Figure 8: The Rear Panel with IEEE-488 Communications

### Serial Interface or IEEE-488 Connector

Slot 1 will contain either the Serial Interface or the IEEE-488 board, depending on which remote communications option you ordered. The remote communications feature allows the 670 instrument to communicate with, and be controlled by, a computer equipped with the appropriate communications software. To use a computer to control the 670 instrument, place the Key Lock switch on the front panel of the 670 instrument in the REMOTE position.

### Serial Interface (RS-232) Connector

The Serial Interface connector is a 9-pin male Type “D” connector. The pinout of the connector is listed in Table 7.

Pinout of the Serial Interface Connector	
Pin Number	Assignment
1	No Connection
2	Transmit Data
3	Receive Data
4	No Connection
5	Digital Ground
6	No Connection
7	No Connection
8	No Connection
9	No Connection

Table 7: Pinout of the Serial Interface Connector

### Note



There is no internal connection on pins assigned a “No Connection” function.

**IEEE Connector**

The IEEE-488 connector is a 24-pin General Purpose Interface Bus (GPIB) connector. The pin assignments, listed in Table 8, comply with the IEEE-488.1 specification.

<b>Pinout of the IEEE-488 Connector</b>		
<b>Pin Number</b>	<b>Abbreviation</b>	<b>Description</b>
1	DIO1	Data Input Output 1
2	DIO2	Data Input Output 2
3	DIO3	Data Input Output 3
4	DIO4	Data Input Output 4
5	EOI	End or Identify (return on pin 24)
6	DAV	Data Valid
7	NRFD	Not Ready for Data
8	NDAC	No Data Accepted
9	IFC	Interface Clear
10	SRQ	Service Request
11	ATN	Attention
12	SHIELD	Shield
13	DIO5	Data Input Output 5
14	DIO6	Data Input Output 6
15	DIO7	Data Input Output 7
16	DIO8	Data Input Output 8
17	REN	Return (return on pin 24)
18	Gnd (6)	Ground (for pin 6)
19	Gnd (7)	Ground (for pin 7)
20	Gnd (8)	Ground (for pin 8)
21	Gnd (9)	Ground (for pin 9)
22	Gnd (10)	Ground (for pin 10)
23	Gnd (11)	Ground (for pin 11)
24	Gnd (LOGIC)	Ground (LOGIC)

Table 8: Pinout of the IEEE-488 Connector

## I/O Connector

The I/O connector provides the following features:

- Interface to a Type 274 multiplexer
- Relay closures for trip points
- $\pm 15$  Volt output signals
- Remote access of the range select, remote zero function, and trip point latch functions
- Pressure output signal

---

**Note**

The Key Lock switch must be in the REMOTE position for the remote range selection, remote zero, and remote trip point latch functions to function.

---

The I/O connector contains one 37-pin female Type “D” connector. The pinout is listed in Table 9, page 37.

### *Interfacing the Type 670 Instrument to a Type 274 Multiplexer*

Use the 670 instrument to configure the channels on the 274 multiplexer. Refer to *How To Interface to the Type 274 Multiplexer*, page 69, for instructions.

---

**Note**

The 670 instrument *cannot* control the heater power on the 274 multiplexer.

---

Use either a CB670-1 or CB670-2 cable to connect the I/O connector to the 274 multiplexer. Refer to *How To Interface to the Type 274 Multiplexer*, page 69, for a description of the cables.

### Pressure Output Signal

The analog pressure output signal, available on pin 36 of the I/O connector and pin 1 on the Signal connector on the Signal Conditioner board, is a 0 to 10 VDC signal (on each range). Refer to Table 9, page 37, for the complete pinout of the I/O connector. A 10 Volt signal corresponds to a full scale pressure signal; a 1 Volt signal corresponds to a 10% of full scale pressure signal. The pressure output signal is independent of the pressure units.

Use pin 1 on the Signal connector to access the pressure output signal if your 670 instrument is connected to a 274 multiplexer. The CB670-1 or CB670-2 cable occupies the I/O connector when the 670 instrument is connected to the 274 unit.

Pinout of the I/O Connector Pinout			
Pin Number	Assignment	Pin Number	Assignment
1	Trip Point A NC	20	Trip Point A Common
2	Trip Point A NO	21	Trip Point B Common
3	Trip Point B NC	22	Trip Point B NO
4	Digital Ground	23	$\overline{\text{x1 Range ID}}$
5	$\overline{\text{x0.1 Select}}$	24	$\overline{\text{x0.01 Select}}$
6	$\overline{\text{Special}}$	25	$\overline{1}$
7	$\overline{10}$	26	$\overline{100}$
8	$\overline{1K}$	27	$\overline{10K}$
9	$\overline{\text{Latch TP B}}$	28	$\overline{\text{Select Channel 2}}^*$
10	$\overline{\text{Latch TP A}}$	29	$\overline{\text{Select Channel 1}}^*$
11	Reserved	30	+15 V
12	$\overline{\text{Remote Zero}}$	31	-15 V
13	Reserved	32	Power Ground
14	$\overline{\text{Channel 3 ID}}$	33	Reserved
15	$\overline{\text{Channel 2 ID}}$	34	Reserved
16	$\overline{\text{Channel 1 ID}}$	35	Analog Ground
17	Reserved	36	Pressure Output
18	$\overline{\text{x0.01 Range ID}}$	37	Reserved
19	$\overline{\text{x0.1 Range ID}}$	<i>NC = Normally Closed NO = Normally Open</i>	
* The 274 multiplexer uses these pins select the active channel. Both pins 28 and 29 high when Channel 3 is the active channel.			

Table 9: Pinout of the I/O Connector

## Signal Conditioner Board

The Signal Conditioner board provides the interface between the 670 instrument and the pressure transducer. The board contains two connectors: an upper connector labeled “Head,” and lower connector labeled “Signal.”

### *Head (Upper) Connector*

The Head connector is a 15-pin female Type “D” connector that enables the 670 instrument to connect to a pressure transducer. Refer to Table 10 for the pin assignments.

<b>Pinout of the Head Connector Pinout (on the Signal Conditioner Board)</b>	
<b>Pin Number</b>	<b>Assignment</b>
1	Chassis Ground
2	Analog Common
3	Heater Return (-38 V)
4	Mux Input
5	No Connection
6	Signal Return
7	Signal Input
8	Heater (+38 V)
9	-13 V
10	+13 V
11	No Connection
12	Reserved
13	Preamp (+12 V)
14	System Check
15	Oscillator (6 VAC)

Table 10: Pinout of the Head Connector on the Signal Conditioner Board

### Note



1. A “No Connection” pin assignment refers to a pin with no internal connection. A “Reserved” pin assignment means that the pin has an internal connection and may be assigned a function in the future.
2. Use pin 1 to access the pressure output signal if your 670 instrument is connected to a 274 multiplexer.

**Signal (Lower) Connector**

This 9-pin male Type “D” connector allows an external device to access the range selection circuits. The three ranges (x1, x0.1, x0.01), along with a 0 to 10 VDC output on each range, are available through this connector. Table 11 lists the pin assignments.

<b>Pinout of the Signal Connector Pinout (on the Signal Conditioner Board)</b>	
<b>Pin Number</b>	<b>Assignment</b>
1	Pressure Output
2	No Connection
3	Select x0.1 Range *
4	Select x0.01 Range *
5	Digital Ground
6	Chassis Ground
7	No Connection
8	Output Return
9	No Connection
<i>* To select the x1 range, leave both pins 3 and 4 high (open)</i>	

Table 11: Pinout of the Signal Connector on the Signal Conditioner Board

**Note**

1. The Key Lock switch must be in the REMOTE position for the remote range selection function to be accessed from this connector.
2. A “No Connection” pin assignment refers to pins with no internal connection.

## Power Entry Module

The Power Entry module contains:

- Line voltage selector
- IEC power line connector
- Power line fuses (2)
- RFI power line filter

For information on the line voltage selector, refer to *How To Change the Line Voltage Selection*, page 82. *Maintenance*, page 128, discusses the types of fuses used, and how to replace them.

## Labels

The rear panel of the 670 unit carries labels to identify each board, alert the user to read the manual for more information, designate alternating current power, and show the international symbols for “on” and “off” positions on the power switch.

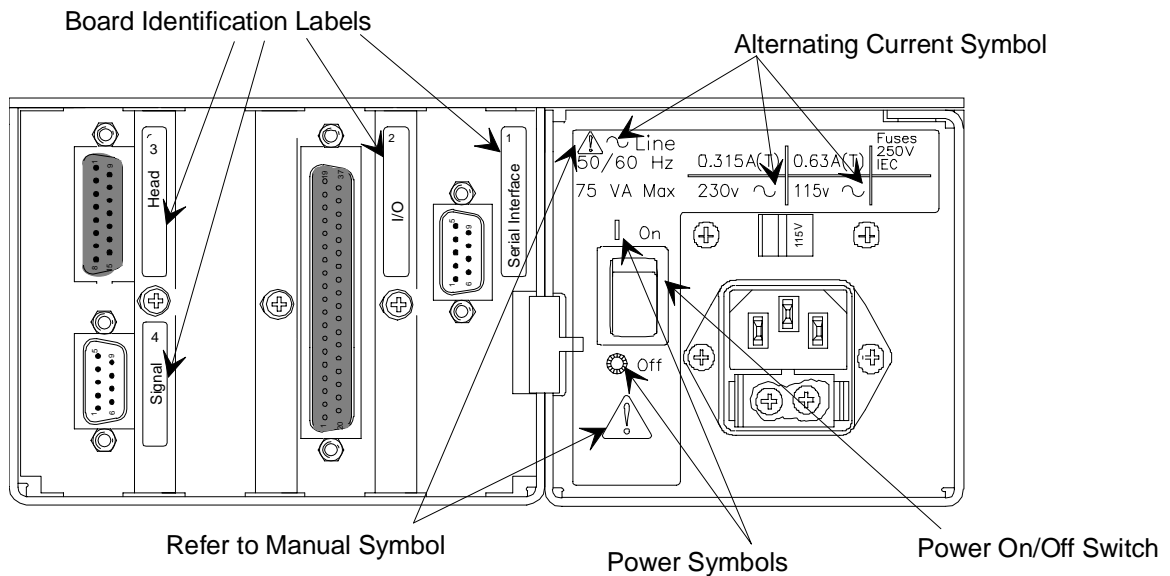

Figure 9: Labels on the Rear Panel

### Serial Number Label

The serial number label, affixed to the side of the unit, lists the model code of the unit.



Figure 10: Serial Number Label

This page intentionally left blank.

## Chapter Four: Functional Overview

### General Information

This chapter presents a global view of the 670 functionality. For detailed instructions on how to perform a specific task, refer to *Chapter Five: Operation*, page 67.

#### Note



To operate the 670 instrument from the front panel, place the Key Lock switch in the LOCAL position. Refer to *Key Lock Switch*, page 31, for more information on this switch.

### Color Coded Keys



The front panel keys are color-coded to indicate functional associations, as listed in Table 12.

Color Coding of Front Panel Keys		
Function	Keys	Color
Channel selection	[Ch 1] [Ch 2] [Ch 3]	Green
Range selection	[x1] [x0.1] [0.01] [AUTO]	Blue
Configuration	[CAL] [ZERO] and [SETUP]	Black
Trip Points	[TRIP POINTS] LEDs A and B	Red

Table 12: Color Coding of Front Panel Keys

To select a function, press the key and a small green indicator light, in the upper left-hand corner of the key, will illuminate. In this chapter, the functions and submenus associated with each key on the front panel display are discussed.

### Scrolling

To scroll through the screens associated with each key, press either arrow key (  or  ). The light on the key will remain illuminated as you scroll through its menus. To return to the pressure display screen, press the key again, and the green light will turn off as you exit the menu.

## How To Change Entries

The menus consist of two types of entries; those you choose from a list of options, and those that require you to enter a value. To choose an entry from a list of options, use the Adjust knob to scroll through the options. For entries that require you to enter a value, use the [CURSOR] key to move the cursor from left to right, and the Adjust knob to change the value of each digit. Initially, the cursor is positioned at the first digit on the left, normally a  $\pm$  sign. Press the cursor key to move the cursor one place to the right. Once the cursor is positioned on the last digit and you press the [CURSOR] key again, it returns to the first digit. To enter a value, press the [ENTER] key or any mode key.

When multiple entries appear on the screen, use an arrow key, ( [△] or [▽] ), to select each entry. The cursor indicates the active entry. Set the entry to the appropriate value in the manner described above. Once you have scrolled through all the entries on the screen, press an arrow key to advance the display to the next screen.

---

**Note**

Press any configuration key to return to the pressure display screen after you have entered or changed an entry. Otherwise, you may change the parameter by inadvertently moving the Adjust knob.

---

### *Invalid Entries*

The 670 instrument will not accept an invalid entry in any of the menu screens. If you enter an invalid entry and attempt to leave the screen by pressing an arrow key, the screen changes the entry to the last valid number entered. You must press an arrow key again to leave the screen. If you attempt to exit the screen by pressing a mode key, the pressure display screen appears, however, the screen entry reverts to the last valid number entered. The change is not visible until you re-enter the menu screen.

## Display Screen

The main pressure display screen shows the active channel number on the left and the pressure reading on the right. The pressure display screen below shows Channel 1 as the active channel, reading atmospheric pressure:

Ch 1	760 Torr
------	----------

The pressure display screen can also display the heater current power consumption and software version number. For more information, refer to *How To Display the Heater Current with the Pressure Reading*, and *How To Display the Software Version Number*, both on page 81.

## How To Change Channels

If you are using the 670 instrument with a single pressure transducer, the active channel will always be Channel 1. Pressing the other channel number keys will have no effect.

### *Channel Selection Using the 274 Multiplexer*

If you are using the 670 instrument with a 274 multiplexer, you can display data from Channels 1 through 3, individually. To select the active channel, press the appropriate channel selector key on the front panel. Be sure that the CHANNEL SELECT switch on the 274 multiplexer is in the REM position.

## The [SETUP] Key

The [SETUP] key enables you to configure the operational parameters of the 670 instrument.

### Display Size

Ch 1	760 Torr
Display Size	5½

The 670 instrument displays the pressure reading as a 3½, 4½, or 5½ digit number. To set the display size, turn the Adjust knob to toggle through the three options. This entry effects the data format used to report data by the remote communication options.

**Response**

Ch 1	760 T
Response 400 mSec.	

The response can be set to 1, 40, or 400 milliseconds. The response entry selects the filter used to reduce noise in the pressure signal *before* it goes to the analog-to-digital (A/D) converter. This entry affects the displayed value, the value reported by the remote communications, and the pressure output signal. Setting the response too low may cause a noisy signal. Use the Adjust knob to toggle through the three options.

**Note**

The response entry does not affect the sampling period of the A/D converter or the display update rate. The A/D converter samples every 0.1 seconds (ten times per second). The pressure reading in the display is updated every 0.25 seconds (four times per second).

<b>Instrument Response Settings</b>	
<b>Milliseconds</b>	<b>≈3 db Frequency (Hz)</b>
1	165
40	4
400	0.4

Table 13: Instrument Response Settings

*Averaging*, page 51, discusses the relationship between the response and averaging entries.

## Heater

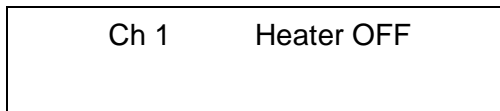

This entry allows you to select whether the 670 instrument supplies power to a heated pressure transducer. The Adjust knob toggles between ON and OFF. The purpose of displaying the heater current is to indicate when the transducer has reached thermal equilibrium. The most accurate readings are attained when the transducer is thermally stable.

You can configure the main pressure display screen to list the amount of power used when the heater is turned ON. Refer to *How To Display the Heater Current with the Pressure Reading*, page 81, to display the heater current along with the pressure reading in the main pressure display screen. The amount of power is expressed as a percentage and ranges from 0 to 100%. When the heater goes from OFF to ON, the percentage of power used is very high, close or equal to 100%. Only a small percentage of power is used to maintain the desired temperature once the transducer is warmed up. The maintenance value will vary with ambient temperature, and from one transducer to another.

---

**Note**

Set the Heater entry OFF if:

1. You are not using a heated transducer.
  2. You are using a 274 multiplexer. The 274 multiplexer supplies the power to heat the transducers.
  3. There is no transducer connected to the 670 unit.
- 

For more information, refer to *How To Display the Heater Current with the Pressure Reading*, page 81.

## Pressure Units

Ch 1	760 Torr
Pressure Unit:	Torr

The 670 instrument can display the pressure reading in Torr, mmHg, mbar, Pa, kPa, psi, inHg, inH<sub>2</sub>O, cmH<sub>2</sub>O, % Full Scale, ppm, and mTorr. Use the Adjust knob to scroll through the pressure units. This entry determines the units used for the pressure reading shown on the display and reported through remote communications.

---

**Note**

If your pressure transducer is calibrated in units other than Torr, you must select the pressure unit used to calibrate the transducer *before* you select the sensor range and calibrate the full scale voltage. Once the full scale voltage is calibrated, you can change the pressure unit entry to display the reading in any unit.

---

For more information, refer to *How To Set the Sensor Full Scale Entry*, page 71.

## Sensor Range

Ch 1	Sensor Range
	±1.00000E+3Torr

The sensor range entry, used in conjunction with the pressure units entry, sets the full scale reading of the pressure transducer. Set this entry to the full scale value of the transducer. Use the [CURSOR] key and the Adjust knob to change the sensor range value.

The actual output of the pressure transducer does not vary when you change the sensor range entry. This entry only changes the scale applied to the signal when it is converted into a pressure reading. For example, if the full scale output was calibrated as a 100 Torr unit, set the sensor range entry to 1.00000E+2 Torr. A signal 50% of full scale would correspond to a 50 Torr reading. If you set the sensor range entry to 2 Torr, the same 50% of full scale signal would correspond to a 1 Torr pressure reading.

### *The Effect of Changing the Pressure Units*

For example, assume that you have a 100 Torr pressure transducer that was calibrated in Torr, and the pressure units entry is set to Torr. The correct sensor range entry would be 1.00000E+2 Torr. To display the pressure reading in mbar, change the pressure units entry to mbar. The sensor range entry will then display 133.3 mbar as the full scale reading, because a pressure of 100 Torr is equivalent to 133.3 mbar. A full scale pressure signal would now correspond to a pressure of 133.3 mbar. To configure the full scale reading for sensors that have been calibrated in units other than Torr, refer to *How To Set the Sensor Full Scale Entry*, page 71.

The analog output pressure signal is always a 0 to 10 Volt signal, representing 0 to full scale pressure.

### *Using the 670 Unit with a 274 Multiplexer*

When the HEAD RANGE IN TORR switch on the 274 multiplexer is set to the SP position, the 670 unit determines the sensor range based on this entry. When the HEAD RANGE IN TORR switch is set to any position other than the SP position, the 274 head range selection overrides the 670 sensor range entry. In this case, the 670 instrument updates the sensor range entry to match the 274 setting.

For more information, refer to *How To Set the Sensor Full Scale Entry*, page 71.

## Temperature Compensation

Ch 1	Temperature
Compensation:	+500

This screen allows you to use the 670 instrument to set the temperature compensation of a bakeable transducer, such as the 315, 317, 615, 616, 617. The Types 310, 370, 390, 391, 398, 590, 690, 698 transducers do not need to have the temperature compensation changed. This function corrects for gain changes on pressure transducers with user selectable temperatures. Refer to your transducer manual for details.

The temperature compensation entry can range from 0 to 999. Use the [CURSOR] key and the Adjust knob to change the value of the temperature compensation. Set the temperature compensation entry to 500 if your transducer does not need the temperature compensation setting adjusted.

### Note



---

*If you are using a Type 274 multiplexer:* Place the TEMP COMP switch on the 274 unit to the OUT position for each channel. This allows the 670 instrument (rather than the 274 unit) to control the temperature compensation value. Refer to *How To Interface to the Type 274 Multiplexer*, page 69, for additional information.

---

## Averaging

Ch 1      760 Torr
Averaging: 20

This screen displays the averaging entry that defines number of readings the 670 instrument will average to establish the pressure reading. By averaging multiple data points, you can smooth the pressure signal from an unstable system.

### Note



The averaging feature only effects the displayed pressure reading and the value reported by the remote communications. It does *not* effect the pressure output signal.

To utilize averaging for the remote communications, refer to *Chapter Six: RS-232 Communications Option*, page 85, for more information about RS-232 commands, or *Chapter Seven: IEEE-488 Communications Option*, page 103, for information on the IEEE-488 command.

### How Averaging Works

The averaging feature employs a moving average, continually dropping the oldest data point and adding the latest data point. The sampling rate is fixed at 10 samples per second. Figure 11 shows how the 670 instrument computes an average of 5 data points.

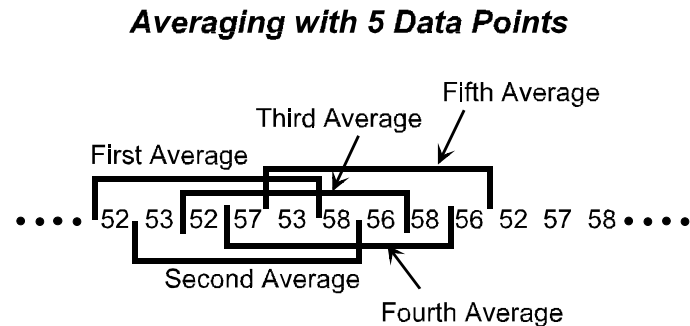

Figure 11: Averaging with 5 Data Points

A new data point is read every tenth of a second (a fixed sampling rate of 10 samples per second). The first average represents the average of the following 5 data points:

$$\begin{array}{r}
 52 \\
 53 \\
 52 \\
 57 \\
 \underline{53} \\
 267 \div 5 = 53.4
 \end{array}$$

The pressure reading is 53.4 at time T+0.5. At time T+0.6, the 670 instrument computes a new moving average, dropping the oldest value, 52 in the example above, and adding the reading collected at time T+0.6, in this case 58:

$$\begin{array}{r} 53 \\ 52 \\ 57 \\ 53 \\ \underline{58} \\ 273 \div 5 = 54.6 \end{array}$$

The pressure reading changes from 53.4 to 54.6.

Use the averaging entry, in conjunction with the response entry, discussed on page 46, to achieve the best compromise between a quick response and minimal digit flickering. Refer to Table 14 for the optimal averaging and response entries.

<b>Optimal Averaging and Response Entries</b>	
<b>Averaging Entry</b>	<b>Response Entry</b>
1 - 3	1
4 - 9	40
10 - 100	400

Table 14: Optimal Averaging and Response Entries

In general, an averaging entry of 20 and a response entry of 400 milliseconds offers an acceptable response. If you are using the 670 instrument in a pressure control application, set the response entry to 1 millisecond.

The number of samples to average can range from 1 to 100, inclusive. The initial averaging value is 20.

### ***Disabling Averaging***

To disable averaging, set the averaging entry to 1. This causes the 670 instrument to report each pressure reading independent of the preceding value. In the previous example, the pressure reading would change from 53 to 58.

### RS-232 Communication Parameters (Optional)

**Note**



This screen only appears when the 670 instrument is equipped with the RS-232 remote communications option. It does not appear when the 670 instrument has the IEEE-488 communications option.

RS232:	9600 Baud
8 Bit	NO Parity

Select the RS-232 communications parameters using this screen. Use an arrow key ( [△] or [▽] ) to move through the entries. Use the Adjust knob to scroll through the options for each entry. The default settings are: 9600 Baud, 8 Data Bits, and No Parity.

Refer to *Chapter Six: RS-232 Communications Option*, page 85, for a complete description of the RS-232 communication parameters and protocol.

### IEEE-488 Communication Parameters (Optional)

**Note**



This screen only appears when the 670 instrument is equipped with the IEEE-488 remote communications option. It does not appear when the 670 instrument has the RS-232 communications option.

IEEE-488 Address: 8
---------------------

Select the IEEE-488 device address using this screen. Valid addresses range from 1 to 30. Use the Adjust knob to scroll through the addresses. The initial address is 8.

Refer to *Chapter Seven: IEEE-488 Communications Option*, page 103, for a complete description of the IEEE-488 communication features.

## The [TRIP POINTS] Key

Use the [TRIP POINTS] key to configure the two trip points. Each trip point is defined by a high and low setting and controls a relay. In addition, you choose the initial state of the trip point relays; either energized or de-energized, and the trip point channel.

The 670 instrument contains two trip points; Trip Point A and Trip Point B. You set the high value, the low value, and the hysteresis for each trip point. The trip point entries define a “normal” operating range for the pressure signal. When the pressure signal deviates from this normal range, the relay changes state to indicate an alarm condition.

If the 670 instrument is connected to a 274 multiplexer, you must use the Y-cable, CB670-2, to access the trip point pins available on the I/O connector. Refer to *Appendix D: Interface Cables for a Type 274 Multiplexer*, page 145, for the pin assignments.

### Trip Point Settings

The trip points can be set to any pressure within  $\pm 105\%$  of transducer full scale. If you prefer to use a single pressure threshold as the alarm limit, disable one of the trip points. To disable a high trip point, select a pressure equal to or greater than  $+105\%$  of full scale. To disable a low trip point, select a pressure equal to or less than  $-105\%$  of full scale.

Table 15 summarizes the action of a trip point based on the pressure reading of the selected trip point channel.

Action of the Trip Points	
Pressure Value on the Trip Point Channel	Action
> trip point high value plus hysteresis value	Trip point relay is activated
Equal to or between the trip point high and trip point low values	Trip point relay is not activated
< trip point low value minus hysteresis value	Trip point relay is activated

Table 15: Action of the Trip Points

The trip point settings screens define the high and low settings for Trip Point A (TP A). The [CURSOR] key moves the cursor from left to right on the line, so you can change the trip point value. From the TP A HIGH screen press the down arrow key [▽] moves the cursor to the TP A LOW entry. Press the down arrow key [▽] again to configure the high and low values for Trip Point B.

***Trip Point A Settings***

TP A HIGH  
7.80000E+2 Torr

TP A LOW  
7.40000E+2 Torr

***Trip Point B Settings***

TP B HIGH  
7.80000E+2 Torr

TP B LOW  
7.40000E+2 Torr

These screens define the high and low settings for Trip Point B (TP B). Press the down arrow key [  ] once to scroll to the TP B LOW screen.

## Hysteresis

Hysteresis is built into the operation of the two trip points to help compensate for the noise inherent in all systems. Without hysteresis, the noise may cause the relays to repeatedly switch states, a condition known as “relay chatter.” The amount of hysteresis can be adjusted separately for each trip point.

Setting the hysteresis too high will create a *deadband* around the trip point. The deadband prevents the trip point relay from responding to changes in the pressure signal around the trip point. Ideally, the hysteresis should be close to, but not less than, the peak-to-peak noise. This setting will provide maximum immunity from relay chatter while providing the best possible accuracy. It may take some trial and error efforts to determine the smallest hysteresis setting appropriate for your system to prevent relay chatter.

The hysteresis value is defined as a  $\pm$ percent of the trip point value and can range from 0 to 10%. The 670 instrument adds the  $\pm$  hysteresis value to the trip point value to create a hysteresis band around the trip point, as shown in Figure 12.

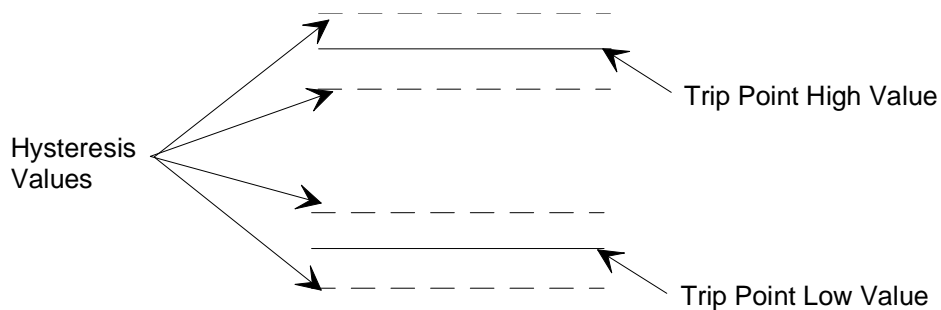

Figure 12: Hysteresis Bands Applied to the Trip Point Values

*Example:* Setting the trip point high value to 100, the trip point low value to 50, and the hysteresis entry to 1%, creates the hysteresis bands shown in Figure 13.

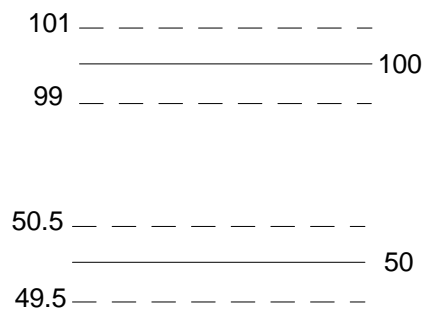

Figure 13: Hysteresis Bands and Trip Point Values

Therefore, the high trip point is activated when the pressure exceeds 101. It is deactivated when the pressure drops below 99. The low trip point is activated when the pressure drops below 49.5. It is deactivated when the pressure exceeds 50.5.

***Hysteresis Screen***

TP A	Hysters:	10.00%
TP B	Hysters:	-10.00%

The hysteresis feature, built into the operation of the two trip points, helps to compensate for the noise inherent in all systems. Excessive noise can cause the trip points to repeatedly switch states, a condition known as “relay chatter.”

The hysteresis value is defined as a  $\pm$  percent of the trip point entry, on the selected range. The entry can range from 0 to 10 %. For example, if TP A HIGH is set to 70 and TP A LOW is set for 50, a hysteresis value to 1%, will create a hysteresis band from 63 to 77 around TP A HIGH, and a hysteresis band from 45 to 55 around TP A LOW.

**Relay State**

You select the state of the relays in the normal operating range, either energized or de-energized. The relay changes state when the pressure reading on the relay channel exceeds the trip point high value *plus* hysteresis value, or drops below the trip point low value minus hysteresis value. For example, if TP A is set as de-energized, it becomes energized when the pressure exceeds the range defined by the trip point values plus the hysteresis value. *Table 15: Action of the Trip Points*, on page 54, describes the action of the trip points based on the pressure reading of the trip point channel.

The relay state entry does not effect the function of the trip point LEDs. The LEDs always illuminate when the pressure reading deviates from the boundaries defined by the trip point high value plus hysteresis, and the trip point low value minus hysteresis. The LEDs are extinguished when the pressure reading is within the trip point boundaries.

***Relay State Screen***

TP A	ENERGIZED
TP B	DE-ENERGIZED

This screen determines the state of the trip points when the pressure is between the high and low trip point values. Set the state as either energized or de-energized. Use the Adjust knob to toggle between ENERGIZED and DE-ENERGIZED. Use the arrow keys to move from one trip point to the other.

The initial value is ENERGIZED for both trip points.

## Channel Selection

Each trip point must be assigned to a channel. If you are using a single pressure transducer, set the trip point channel to Channel 1. If you are using a 274 multiplexer, the trip point channels assigned may differ from the *active* channel.

TP A Channel	#1
TP B Channel	#1

Use the Adjust knob to select the channel (1 through 3) for each trip point. Press the an arrow key to move to the other trip point field.

---

### Note



The Adjust knob scrolls through Channels 2 and 3 even when the 670 instrument is *not* connected to a 274 multiplexer. This enables you to configure the 670 instrument in one location and then insert it into a system with a 274 multiplexer, without modification.

---

## Latching a Trip Point

The 670 instrument provides the ability to “latch” the trip points. Once the latch on a trip point is enabled, the next time the trip point value is crossed (either the pressure exceeds the high trip point, or drops below the low trip point) the relay will remain in that state as long as the latch is enabled, regardless of the pressure value. The trip point relay will return to its normal state only when the latch is either cleared or disabled, *and* the pressure value falls within the normal limits defined by the trip points. Pins on the I/O connector allow you to use an external signal to release the relay, yet maintain the latched mode. The next time that the trip point value is crossed, the relay will become latched again. Refer to *How To Clear a Latched Trip Point*, page 77. The latch feature is useful if you need to implement a manual acknowledgment of an alarm condition.

---

### Note



If the 670 instrument is connected to a 274 multiplexer, you must use the Y-cable, CB670-2, to access the trip point latch pins. Refer to *Appendix D: Interface Cables for a Type 274 Multiplexer*, page 145, for the pin assignments.

---

### *Latch Mode*

TP A LATCH:	ENABLED
TP B LATCH:	DISABLED

Use the Adjust knob to select the state of the latch mode. Press the down arrow key [  ] to set the latch for Trip Point B.

The I/O connector provides the ability to clear latched trip points remotely. Once a trip point has been latched, you can clear the latch to release the trip point from the alarm condition, and maintain the latch enabled mode. The trip point will become latched again should the pressure cross a trip point.

For more information on trip points, refer to:

*How To Configure the Trip Points*, on page 75

*How To Disable a Trip Point*, on page 77

*How To Clear a Latched Trip Point*, on page 77

*How To Adjust Hysteresis*, on page 78

## The [CAL] Key

The [CAL] key presents the calibration information and performs the calibration functions. The message “CALIBRATING” appears on the screen and the channel selector lights extinguish while the 670 instrument performs a calibration procedure. The current value of the entry is listed in the top portion of the screen.

The Null and Full Scale calibrations are performed independently of the pressure transducer. Perform the Null calibration procedure any time the value changes from 0.0000 Volts. Perform the Full Scale calibration procedure whenever the full scale value drifts from 10.000 Volts.

**Note**

When the 670 instrument requires recalibration, run the Null procedure first, followed by the Full Scale procedure, if necessary. Both the Null and Full Scale values effect the output signal voltage.

### Null

NULL      -0.0001 Volts
Press ENTER to cal

This screen displays the null calibration value. The null calibration procedure eliminates any zero errors inherent in the 670 instrument. Press the [ENTER] key to perform the null calibration. The front panel will flash the message “CALIBRATING” while the instrument performs the calibration procedure. Press either of the arrow keys to change to another screen and avoid the calibration procedure.

The pressure transducer does not have to be connected to the 670 instrument for this procedure.

### Full Scale

FS:          9.99998 Volts
Press ENTER to cal

This screen displays the current full scale voltage value. This procedure eliminates any gain errors in the 670 instrument by calibrating the output span to an internal standard. To perform the full scale calibration, press the [ENTER] key. The front panel will flash the message “CALIBRATING” during the full scale calibration procedure. Press either of the arrow keys to change to another screen and avoid the calibration procedure.

The pressure transducer does not have to be connected to the 670 instrument to perform this procedure.

## System Check Calibration

Ch 1	9.9998
SYSCHK	

This screen displays the system check value. This value can be used as a diagnostic tool.

---

**Note**

Be sure that the system is at the correct pressure for the type of transducer, BEFORE using the SYSCHK function. Otherwise, the 670 unit may report erroneous values.

*Absolute Transducers:* Pump the system down to base pressure, that is, a pressure below the resolution of the transducer.

*Differential Transducers:* Equalize the pressure on both the reference (Pr) and measurement (Px) ports.

---

When you enter the SYSCHK screen, the 670 instrument sends out a digital signal to prompt the transducer to return a 10 Volt signal. The value displayed in this screen reflects the value returned by the pressure transducer. The system check value varies for each transducer, and can range from 9.5 to 10.5 Volts. Refer to *Troubleshooting*, page 130, if your SYSCHK value does not fall within this range.

For more information on calibrating the 670 unit, refer to *How To Calibrate the 670 Instrument*, page 72.

## The [ZERO] Key

The [ZERO] key allows you to zero the transducer from the 670 instrument. The 670 instrument performs the zero function on all three ranges (x1, x0.1, and x0.01).

### Zero Enable

Ch 1	760 Torr
Zero Enable: ON	

The zero enable entry must be ON for the 670 instrument to calibrate the zero. Use the Adjust knob to toggle between ON and OFF. With the zero enable set to ON, advance to the zero calibration screen to initiate the zero procedure. When the zero enable is set to OFF, no other screens are available.

When the zero enable is off the signal used to zero the transducer is turned off. This capability is useful in the situation that requires changing the transducer zero adjustment. Refer to your transducer manual for calibration procedures.

---

**Note**

You *cannot* access the zero calibration screen when the zero enable entry is OFF.

---

### Zero Calibration

Ch 1	2E-3 Torr
Press ENTER to zero	

This screen is accessible only when the zero enable entry is set to ON. To start the zero procedure, press the [ENTER] key. The front panel will flash the message “CALIBRATING” during the zero procedure.

---

**Note**

1. Before you initiate the zero procedure, be sure that your system is pumped down to a base pressure *less than* the resolution of the transducer measuring the pressure of the system. Otherwise, the resultant zero setting will be incorrect.
  2. The 670 instrument *cannot* correct for a transducer zero greater than  $\pm 2\%$  of full scale.
-

The zero calibration applies a zero correction factor to assign the present voltage reading a pressure of 0.00 Torr (or to the base pressure reading appropriate for the units you are using). This correction factor accounts for any voltage offset caused by the transducer or the wiring between the transducer and the 670 instrument. When the zero enable is OFF, the 670 instrument does not apply any zero correction factor to the pressure signal. The 670 instrument sets the zero value as close to 0.00 Torr as possible. This allows you to remove any transducer zero without effecting the null calibration.

**Note**

---

When using a Type 274 multiplexer, you must perform the zero calibration on *each* channel you intend to use.

---

***Remote Zero Feature***

The 670 instrument can be zeroed remotely through pins on the I/O connector, when the Key Lock switch is in the REMOTE position.

For more information on the zero feature, refer to:

*How To Calibrate the 670 Instrument*, on page 72

*How To Use the Remote Zero Feature*, on page 80

## The [AUTO] and Range Keys

The [AUTO] key activates the autoranging feature. When the 670 instrument is configured for autoranging, the instrument switches the range automatically to optimize the pressure reading. Both the [AUTO] key and the active range key ( [x1], [x0.1], or [x0.01] ) are illuminated when the autoranging feature is active. Autoranging allows the 670 instrument to produce the most accurate pressure reading throughout the range of the pressure transducer. By changing the range, based on the magnitude of the pressure signal, the 670 instrument can increase the resolution for a low level signal, and decrease the resolution to track a high level signal. Autoranging is useful in situations that require maximum resolution for a system in which the pressure signal may change substantially. However, for pressure control applications, do not use autoranging since the range crossover will cause the analog output signal to change ranges.

Figure 14 demonstrates how autoranging works. In this example, the full scale voltage is set for 10 Volts and the full scale pressure reading is 100 Torr.

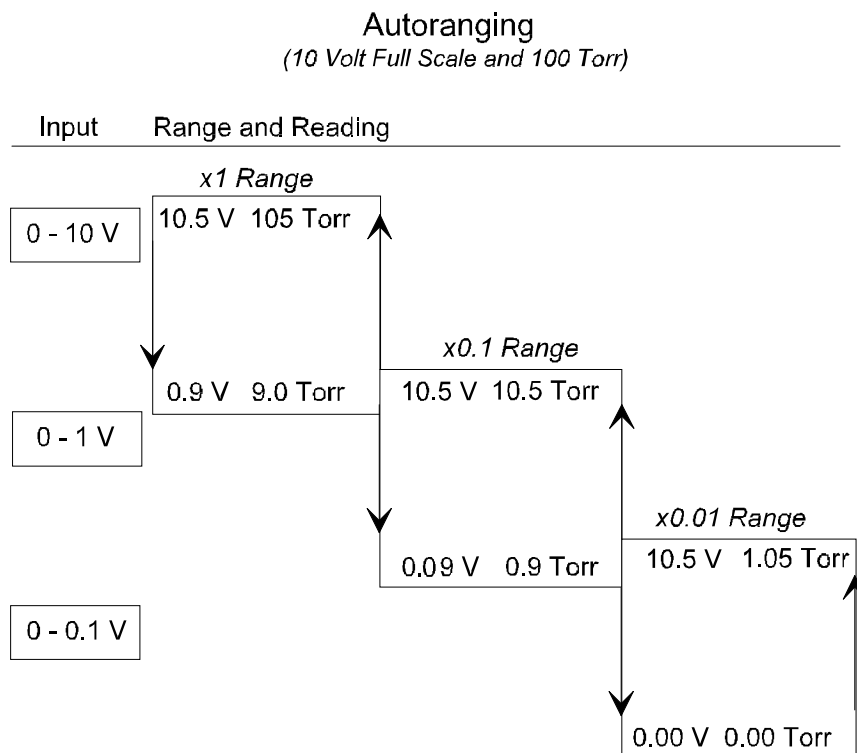

Figure 14: Autoranging on a 10 Volt Full Scale Signal

Following the example in Figure 14, the 670 instrument applies the x1 range to pressure readings between 105% F.S. (105 Torr) and 9% F.S. (9.0 Torr). When the pressure reading drops below 9% of F.S. (9.0 Torr), the 670 instrument applies the x0.1 range. This change adds another

significant digit to the display. The full scale voltage on the x0.1 range is 10 Volts. The range remains at x0.1 for pressure readings between 105% of the *current* range (10.5 Torr) and 9% of the *current* range (0.9 Torr). Once the pressure reading drops below 9% of the voltage range (0.9 Torr), the 670 instrument applies the x0.01 range. The range remains at x0.01 for pressure readings between 105% of the *current* range (1.05 Torr) and zero (0.00 Torr). This range increases the number of significant digits by one.

A differential transducer may generate negative pressure readings. The autoranging sequence is repeated for negative pressure values, up to -105% F.S. Using the example system in Figure 14, page 64, the range remains at x0.01 when the pressure reading drops below zero to -105% of the *current* range (-1.05 Torr). When the pressure drops below -1.05 Torr, the range switches to x0.1. The 670 instrument holds the range at x0.1 for pressure readings between -9% of the *current* range (-0.9 Torr) and 105% of the *current* range (-10.5 Torr). Once the pressure reading drops below -105% of the x0.1 range (-10.5 Torr), the range switches to the x1. The range remains at x1 for pressure readings between -9% of full scale (-9 Torr) and -105% of full scale (-105 Torr).

The display reads `UNDERRANGE` when the pressure is less than -105% of full scale (105 Torr) and `OVERRANGE` when the pressure exceeds +105% of full scale (+105 Torr).

---

**Note**

In the autoranging mode, the display may list `UNDERRANGE` or `OVERRANGE` while changing ranges since the 670 instrument uses all the previous data to calculate the new average. Once the previous data is replaced by new data, or the average value falls within the new range, the out-of-range condition will disappear. To avoid this, reduce the number of samples to average entry. For more information, refer to *Averaging* page 51.

---

### ***De-Selecting the AUTO Operation***

To de-select the AUTO operation, press either the [AUTO] key or a range selection key ( [X1], [X0.1], or [X0.01] ). The 670 instrument either maintains to the last range used while in the AUTO mode (if you press the [AUTO] key), or changes to the new range (if you press another range selection key). The light on the appropriate range selection key illuminates to indicate the active range.

For more information on range selection, refer to *How To Select the Range Setting Remotely*, page 79.

This page intentionally left blank.

## Chapter Five: Operation

### How To Configure the 670 Instrument

This section describes how to connect and configure the 670 instrument.

1. Power up the unit by pressing the On/Off switch to the On position.  
Refer to Figure 7, page 33, for the location of the On/Off switch.
2. Connect the 670 instrument to the pressure transducer.

Figure 15 shows the connection between the 670 instrument and a single pressure transducer. If you are using a Type 274 multiplexer, refer to *How To Interface to the Type 274 Multiplexer*, page 69.

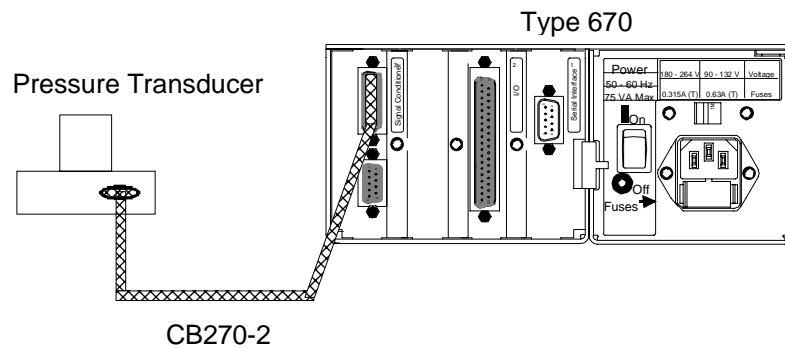

Figure 15: Connecting to a Single Pressure Transducer

3. Press the [SETUP] key.  
The system responds by displaying a configuration screen.
4. Use the arrow keys, ( [△] or [▽] ), to scroll through the screens. Change the configuration, if necessary.  
Refer to *Chapter Four: Functional Overview*, page 43, for information about the setup menu screens. If you need to change the sensor range, follow the directions in *How To Set the Sensor Full Scale Entry*, page 71. The *How To Calibrate the 670 Instrument*, page 72, describes how to calibrate the instrument.
5. Once the 670 instrument is fully configured, press the SETUP key to return to the pressure display screen.
6. Place the Key Lock switch in the desired position.

Refer to *Chapter Three: Hardware Overview*, page 31, for a description of the Key Lock switch. When the Key Lock switch is in the REMOTE position, you can remove the key. The key cannot be removed when the switch is in the LOCAL position.

## How To Interface to the Type 274 Multiplexer

The 670 instrument can interface to the Type 274 multiplexer and display the pressure signal from up to three pressure transducers, individually. Figure 16, page 69, shows the 670 instrument connected to a 274 multiplexer.

### Connecting the Cables

1. Disconnect the power cords from the 670 instrument and the 274 multiplexer.

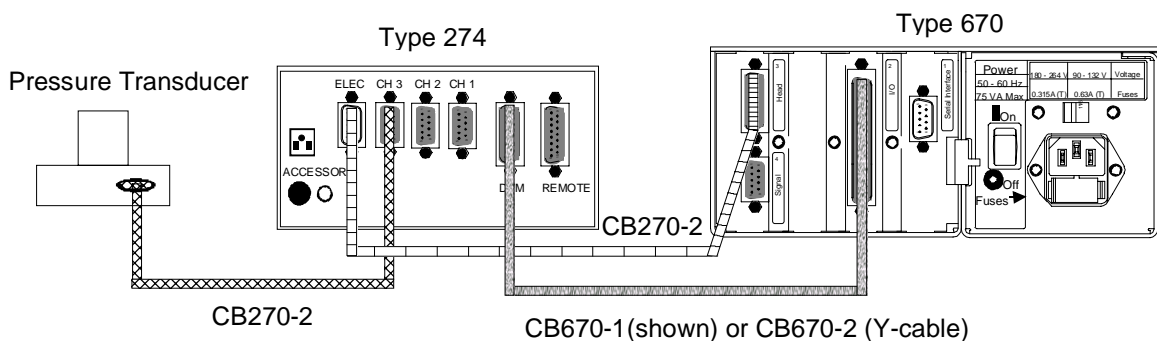

Figure 16: Connecting to a Type 274 Multiplexer

2. Use a CB670-X cable to connect the I/O connector on the 670 instrument to the DVM connector on the 274 multiplexer.

The I/O connector is a 37-pin female connector; the DVM connector is a 25-pin female connector. The CB670-1 cable is a straight cable; the CB670-2 cable is a Y-cable that allows access to the trip point relays, and the remote functions (zero, range select, and trip point latching). Refer to *Appendix D: Interface Cables for a Type 274 Multiplexer*, page 145, for a description of the cables.

3. Use a CB270-2 cable(s) to connect the pressure transducer(s) to the “CH 1,” “CH 2,” or “CH 3,” connector(s) on the 274 multiplexer.
4. Use a CB270-2 cable to connect the Head connector on the 670 instrument to the ELEC connector on the 274 multiplexer.

The Head connector (upper connector on the Signal Conditioner board) is a 15-pin female connector; the ELEC connector is a 15-pin male connector.

## Configuring the 274 Multiplexer

1. Place the CHANNEL SELECT switch in the REM position.

This allows the 670 instrument to select the active channel.

2. Place the TEMP COMP switch (on the left-hand side), in the OUT position, for each channel.

This allows the 670 instrument to set the temperature compensation. Refer to the discussion of the temperature compensation screen, page 50, for details.

3. Turn the REG HEATER switch ON to control the heater power, if necessary. Set this switch for each channel on the 274 multiplexer.

The Heater screen in the [SETUP] menu allows the 670 instrument to provide power to the transducer heater. Refer to *Heater*, page 47, for a discussion of the heater function.

4. Place the HEAD RANGE IN TORR switch, for each channel, in the SP position.

This allows the 670 instrument to set the sensor range. Refer to *Sensor Range*, page 49, for a complete discussion.

5. Plug in the power cord on both the 670 instrument and the 274 multiplexer.

## Configuring the 670 Instrument

To configure the 670 instrument, complete steps 3 through 6 in *How To Configure the 670 Instrument*, page 67.

---

### Note



If you are using heated transducers, turn the Heater entry OFF (in the Setup menu). The 274 multiplexer, rather than the 670 instrument, supplies power to heat the transducers.

---

If the 670 instrument has not been calibrated, complete the steps outlined in *How To Calibrate the 670 Instrument*, page 72. If the 670 instrument has been calibrated, you only need to zero each channel with a transducer connected. Steps 11 through 15 on page 73, describe the zero procedure.

Refer to *How To Set the Sensor Full Scale Entry*, page 71, if you need to change the full scale or pressure unit entries.

## How To Set the Sensor Full Scale Entry

To configure the 670 instrument to work with a pressure transducer, you need to select the sensor range and pressure unit. You should check the label on your transducer to determine both the sensor range and pressure unit used to calibrate the transducer. Be sure that the pressure unit entry is set to the unit used to calibrate the transducer *before* you set the sensor range entry. Once the sensor range is set correctly, you may change the pressure unit entry at any time. The pressure unit entry effects the displayed reading as well as the reading reported by remote communications.

1. Press the [SETUP] key.

The system responds by displaying a setup screen.

2. Repeatedly press either arrow key ( [△] or [▽] ) to scroll to the pressure unit screen.

The system responds by scrolling through the setup screens.

Ch 1	760 Torr
Pressure Unit: Torr	

3. Use the Adjust knob to scroll through the various pressure units and select the unit used to calibrate the transducer full scale value.

The label on your transducer should list the units used to calibrate the transducer.

4. Press the down arrow key ( [▽] ) to scroll to the sensor range screen.

The system responds by scrolling to the sensor range screen.

Ch 1	Sensor Range
±1.00000E+3Torr	

5. Enter the correct sensor range by using the [CURSOR] key to position the cursor on each digit, and then turn the Adjust knob to vary the value of each digit.

The system responds by accepting the new full scale value (if the selection has changed).

6. Press either arrow key ( [△] or [▽] ) to move to another screen.

If you prefer to display the pressure reading in a unit other than the unit used to calibrate the transducer, select the pressure unit screen to change the pressure unit.

7. Once the 670 instrument is fully configured, press the [SETUP] key to return to the pressure display screen.

## How To Calibrate the 670 Instrument

The 670 instrument displays the message “CALIBRATING” during any calibration procedure.

**Note**

Complete the calibration procedure in the order listed below. Failure to do so may result in an invalid calibration.

To calibrate the 670 instrument:

1. Press the [SETUP] key to enter the setup menu.  
The system responds by displaying a setup screen.
2. Repeatedly press either arrow key ( [△] or [▽] ) to scroll to the response screen.  
The system responds by scrolling through the setup screens.
3. Use the Adjust knob to set the response entry to 400 milliseconds. Refer to *Response*, page 46, for a complete description of this entry.

Ch 1	760 Torr
Response:	400 mSec.

4. Repeatedly press the down arrow key ( [▽] ) to scroll to the averaging screen.

Ch 1	760 Torr
Averaging:	20

5. Use the Adjust knob to set the averaging entry to 20.

An averaging entry of 20 is sufficient for the null and full scale calibration procedures. You may need to increase the averaging entry to establish a valid zero. Increasing the averaging entry and the response time will improve the accuracy, however, the instrument response will be slower and the calibration will take longer to complete.

Table 16, page 73, lists the approximate time for each calibration function with various averaging entries.

Relationship Between Averaging Entry and Calibration Times					
Averaging Entry:	20	40	60	80	100
Null	17 sec.	24 sec.	32 sec.	40 sec.	49 sec.
F.S.	9 sec.	13 sec.	17 sec.	20 sec.	24 sec.
Zero	21 sec.	30 sec.	39 sec.	50 sec.	1 min.

Table 16: Relationship Between Averaging Entry and Calibration Times

Refer to *Averaging*, page 51, for more information.

6. Press the [CAL] key to enter the calibration menu.
7. Repeatedly press either arrow key ( [△] or [▽] ) to scroll to the null screen.

NULL      -0.0001 Volts Press ENTER to cal
---

8. Press the [ENTER] key to initiate the null calibration routine.  
 This step may take several minutes to complete, depending upon the averaging entry. Refer to Table 16 for an approximate time. The message “CALIBRATING” will flash on the display until the calibration procedure is complete. The reading should go to  $0.000 \pm 0.0005$ . If the reading does not approach 0.000, press the [ENTER] key again to repeat the null calibration routine.
9. Repeatedly press either arrow key ( [△] or [▽] ) to scroll to the full scale screen.

FS:            9.99998 Volts Press ENTER to cal
--

10. Press the [ENTER] key to initiate the full scale (FS) calibration routine.  
 The message “CALIBRATING” will flash on the display during the calibration process. The reading should go to  $10.000 \pm 0.0005$ . If the reading does not approach 10.000, press the [ENTER] key again to repeat the F.S. calibration routine.
11. Pump down the system to a pressure less than the resolution of the pressure transducer.  
 To achieve a proper zero, the pressure of the system must be *less than* the resolution of the pressure transducer used to measure the system pressure. The transducer will not be

zeroed if the output of the transducer is greater than 2% of the sensor full scale range. Refer to the pressure transducer instruction manual for the proper pressure for your transducer. It may take several hours to achieve an acceptable base pressure.

12. Press the [ZERO] key.
13. Use the Adjust knob to set the zero enable entry to ON.

Ch 1	2.14E-3 Torr
Zero Enable: ON	

14. Press the down arrow key (  ) to scroll to the zero screen.

Ch 1	2.14E-3 Torr
Press ENTER to zero	

This screen will not appear if the zero enable entry is set to OFF.

15. Press the [ENTER] key to initiate the zero procedure.

The message “CALIBRATING” will flash on the display until the calibration procedure is complete. The system responds by zeroing the pressure transducer.

If the 670 instrument is unable to establish an acceptable zero, you may need to increase the averaging entry. Repeat steps 4 and 5 and increase the averaging entry. Setting the averaging entry higher than 20 may increase the accuracy of the calibration, however, the calibration procedure will take longer to complete. You do *not* need to repeat the null and F.S. calibrations if you change the averaging entry.

16. Press the [ZERO] key to return to the pressure display screen.
17. If you prefer to use another value for the averaging entry, press the [SETUP] key, use the arrow keys to scroll to the averaging screen, and reset the averaging entry.

### **Additional Calibration for the Type 274 Multiplexer**

To calibrate a 670 instrument connected to a 274 multiplexer, complete the procedure described above and repeat steps 11 through 17 for each channel. This configures the zero setting for each channel.

## How To Configure the Trip Points

The 670 instrument has two trip points, and each trip point controls a relay. The relays provide 24 Volts AC/DC @1 Amp resistive (contact rating) power. You assign a channel number, an initial state, and high and low values for each trip point. Refer to *The [TRIP POINTS] Key*, page 54, for a complete description of trip points.

1. Connect the trip point relays, on the I/O connector, to your system.

Table 9, page 37, lists the complete pinout for the I/O connector.

2. Press the [TRIP POINTS] key on the front panel of the 670 instrument.

The system responds by displaying the screen below.

<p>TP A HIGH 7.80000E+2 Torr</p>
--------------------------------------

3. Use the [CURSOR] key and the Adjust knob to set the value for the TP A HIGH entry.

The entry can vary from  $\pm 105\%$  of full scale. The actual signal output depends on the range selection.

---

**Note**



A +105% of full scale setting for the high entry or a -105% of full scale setting for a low entry, *disables* the trip point.

---

4. Press an arrow key to move the cursor the to TP B entry.

The system responds by displaying the value of the TP A LOW entry.

5. Use the [CURSOR] key and the Adjust knob to set the value for the TP B HIGH entry.

Refer to step 3 above for an explanation of the setting.



---

**Note**



Switching the range may delay the response of the trip points to a change in pressure. Immediately after the range changes, the 670 unit waits until a stable pressure reading is achieved before activating the trip point.

---

6. Repeatedly press an arrow key (  or  ) to display the relay state screen.

The system responds by displaying the relay state screen.

<p>TP A      ENERGIZED</p> <p>TP B      ENERGIZED</p>
---

7. Use the Adjust knob to set the normal state for TP A.  
The Adjust knob alternates between ENERGIZED and DE-ENERGIZED.
8. Press an arrow key to move the cursor to the TP B entry.  
The system responds by moving the cursor to the TP B entry.
9. Use the Adjust knob to set the normal state for TP B.
10. Press the down arrow key ( [▽] ) once to display the channel selection screen.  
The system responds by displaying the channel selection screen.

TP A Channel	#1
TP B Channel	#1

11. Use the Adjust knob to assign a channel for TP A.  
The system responds by scrolling through Channels 1 through 3. Channel 1 is available on the 670 instrument itself; Channels 2 through 3 are available when the 670 unit is connected to a 274 multiplexer.

**Note**

---

The Adjust knob scrolls through Channels 2 and 3 even when the 670 instrument is not connected to a 274 multiplexer. This enables you to configure the 670 instrument in one location and then insert it into a system with a 274 multiplexer, without modification.

---

12. Press an arrow key to move the cursor to the TP B entry.  
The system responds by moving the cursor to the TP B entry.
13. Use the Adjust knob to assign a channel for TP B.  
Refer to step 11 for instructions on selecting a trip point channel.
14. Press an arrow key to move to the TP Latch screen.
15. Use the Adjust knob to set the latch for each trip point.
16. Once the trip points are configured, press the [TRIP POINTS] key again to return to the pressure display screen.

## How To Disable a Trip Point

Refer to *The [TRIP POINTS] Key*, page 54, for a complete description of trip points.

- Setting the trip point high entry to +105% of full scale disables the trip point
- Setting the trip point low entry to -105% of full scale disables the trip point

For example, if the sensor range is set to 1000 Torr, and you wish to disable the high trip point, set the trip point high entry to 1050 Torr. To disable the low trip point, set the trip point low entry to -1050 Torr.

## How To Clear a Latched Trip Point

Refer to *The [TRIP POINTS] Key*, page 54, for an explanation of the trip points, and the latching feature.

A trip point latch can be enabled through the `TRIP POINTS` menu screen on the front panel, or through a remote communications command. Follow this procedure to release a latched trip point and maintain the latch as enabled. Once the latch is cleared, the trip point will become latched again should the pressure cross a trip point.

1. Place the Key Lock switch in the `REMOTE` position.
2. Connect the I/O connector pins, as described in Table 17, to clear a latched trip point(s).

<b>Connections to Latch the Trip Points</b>		
<b>To Latch Trip Point:</b>	<b>Connect Pin:</b>	<b>To Pin:</b>
A	10 (latch TP A)	4 (digital ground)
B	9 (latch TP B)	4 (digital ground)

Table 17: Connections to Clear a Latch on the Trip Points

Maintain this connection for at least 100 milliseconds to clear the latch on the appropriate trip point.

3. To release the clear signal, release the connection, so the pins float high.

Refer to Table 9, page 37, for the complete list of pin assignments for the I/O connector.

## How To Adjust Hysteresis

Refer to *The [TRIP POINTS] Key*, page 54, for a complete description of trip points and hysteresis.

1. Press the [TRIP POINTS] key.  
The system responds by displaying a trip points screen.
2. Repeatedly press an arrow key ( [△] or [▽] ) to scroll to the hysteresis screen:

TP A	Hyst:	1.00%
TP B	Hyst:	1.00%

The system responds by displaying the screen with the cursor positioned at the entry for TP A if you pressed the down arrow [▽] key and TP B if you pressed the up arrow [△] key.

3. Use the [CURSOR] key and the Adjust knob to adjust the hysteresis value.  
The system responds by accepting the new hysteresis value for TP A.
4. Press the down arrow key ( [▽] ) to edit the hysteresis value for TP B.  
The system responds by moving the cursor to the entry for TP B.
5. Use the [CURSOR] key and the Adjust knob to adjust the value.  
The system responds by accepting the new hysteresis value for TP B.
6. Press the [TRIP POINTS] key to return to the pressure display screen.

## How To Select the Range Setting Remotely

The Head connector on the Signal Conditioner board provides the ability to select the range setting remotely.

1. Place the Key Lock switch, located on the front panel, in the REMOTE position.
2. To select the desired range, apply the appropriate signal to pins 3 and 4 on the Head (lower) connector of the Signal Conditioner board.

Table 18 lists the logic levels and the corresponding ranges.

<b>Pin State for Remote Range Selection</b>		
<b>Range</b>	<b>Head (Lower) Connector on the Signal Conditioner Board</b>	
	<b>Pin 3</b>	<b>Pin 4</b>
x1	HI	HI
x0.1	LO	HI
x0.01	HI	LO

Table 18: Pin State for Remote Range Selection

Refer to Table 11, page 39, for a complete list of the pin assignments for the Head connector on the Signal Conditioner board.

## How To Use the Remote Zero Feature

The I/O connector provides the ability to zero the 670 instrument remotely. The 670 instrument uses an edge trigger to activate the remote zero function. Edge triggering requires that pins change from one state to another before the function will occur. The function will not be repeated until the *transition* occurs again. The pins on the I/O connector float high when open (disconnected). To activate the remote zero feature, pull the pins low (transition from high to low). Refer to *The [ZERO] Key*, page 62, for information on the zero function.

1. Check that the zero feature is enabled.

If you are using remote communications, send the appropriate command to enable the zero. If you are in LOCAL operation, press the [ZERO] to check the state of the zero function. Adjust if necessary.

2. Place the Key Lock switch, located on the front panel, in the REMOTE position.



3. Pump down the system to a pressure less than the resolution of the pressure transducer.

To achieve a proper zero, the pressure of the system must be *less than* the resolution of the pressure transducer used to measure the system pressure. The transducer will not be zeroed if the output of the transducer is greater than 2% of the sensor full scale range. Refer to the pressure transducer instruction manual for the proper pressure for your transducer. It may take several hours to achieve an acceptable base pressure.



4. Connect pin 12 (remote zero) to pin 4 (digital ground) on the I/O connector and hold the connection for at least 200 milliseconds.

The remote zero function uses edge triggering so that the command is only executed once when the remote zero pin is brought low. If you need to repeat the zero procedure, you must release the connection for 200 milliseconds, to allow the line to float high. When you reestablish the connection, the line will be pulled low again, and the instrument will perform the zero function.

## How To Display the Software Version Number

1. From the pressure display screen, press an arrow key (  or  ) until the software version number display screen appears.

The version number is displayed below the pressure reading.

2. Press an arrow key (  or  ) to return to the pressure display screen.

The instrument scrolls to the pressure display screen.

Ch1      760 Torr V1.2 RS232C	or	Ch1      760 Torr V1.2 IEEE-488
----------------------------------	----	------------------------------------

## How To Display the Heater Current with the Pressure Reading

The 670 instrument can display the amount of power being supplied to a heated transducer, along with the pressure reading. Once you select this screen, it will appear every time you exit out of a menu. Once you power down, the normal pressure display screen (without the heater status) will reappear, however. Refer to *Heater*, page 47, for more information.

- From the normal pressure display screen, that appears upon power-up, press the down arrow key (  ).

The instrument displays both the pressure reading and the heater current.

Ch 1      760 Torr heater: 100%
------------------------------------

The software version is also displayed briefly upon startup.

## How To Change the Line Voltage Selection

The 670 instrument can use power from any of the following line voltages:

- 100 to 120 VAC nominal on the 115 V setting (*factory default setting*)
- 200 to 240 VAC nominal on the 230 V setting

To change the line voltage:

1. Disconnect the power cord from the 670 instrument.

### **Warning**



---

**To avoid an electrical shock, be sure to disconnect the power cord *before* proceeding.**

---

2. Disconnect all cables from the connectors located at the back of the unit.
3. Locate the Line Voltage selector switch on the rear panel of the 670 instrument.  
Refer to Figure 7, page 33, for the location of the Line Voltage selector switch.
4. Insert a small device, for example, a screwdriver, to slide the switch so the “115V” label is visible to operate in the 115 V range, or so the “230V” label is visible to operate in the 230 V range.

## How To Use the SYSCHK Feature

Refer to *System Check Calibration*, page 61, for a description of the SYSCHK feature.

1. Verify that all vacuum fittings are tight.
2. For an absolute transducer, pump down the system to a base pressure less than the resolution of the transducer. For a differential transducer, equalize the pressure on both the reference port (Pr) and the measurement port (Px).

Refer to the transducer manual for pump down instructions.

3. Press the [CAL] key to enter the calibration screen.
4. Press an arrow key, ( [△] or [▽] ), until the system check screen appears.

Ch 1	9.8799 Volts
SYSCHK	

The SYSCHK reading should be between 9.5 and 10.5 Volts. A SYSCHK value outside this range, indicates a problem with the pressure transducer or its cable.

This page intentionally left blank.

## Chapter Six: RS-232 Communications Option

### General Information

#### Note



The information in this chapter *only* applies if your 670 instrument is configured with the RS-232 Communications option. If your 670 instrument is configured with the IEEE-488 communication option, refer to *Chapter Seven, IEEE-488 Communications Option*, page 103, for remote communications information.

To configure the 670 instrument to accept commands issued through serial communications, place the Key Lock switch, located on the front panel, in the REMOTE position. While operating the 670 instrument in the REMOTE mode, the front panel controls are locked out and the display shows status information only. The 670 instrument expects to receive commands and instructions through the serial port or the rear panel connectors. When the Key Lock switch is in the LOCAL position, the 670 instrument behaves in the opposite manner — it accepts commands from the front panel only and ignores commands issued by serial communications. Only status information is available through serial communications.

Figure 6, page 31, shows the location of the Key Lock switch.

### Communication Parameters

The RS-232 communication parameters are accessed from the [SETUP] key. Initially, the 670 instrument is configured at 9600 Baud, 8 Data Bits, and No Parity. Table 19 lists the setting for all the communication parameters.

RS-232 Communication Parameters		
Parameter	Options	Page Reference
Baud Rate*	300, 1200, 2400, 4800, 9600†	53
Number of Data Bits*	7, 8†	53
Parity*	Even, Odd, No†	53
Stop Bits	1	Cannot be changed
End-of-Line delimiter	CR	Cannot be changed
<p style="text-align: center;">* denotes user selectable † indicates the initial setting</p>		

Table 19: RS-232 Communication Parameters

## RS-232 Protocol

Messages sent to the 670 instrument are either *commands* that instruct the instrument to change an operating parameter, or *requests* that prompt the instrument to report information.

Responses sent by the 670 instrument either acknowledge a command issued by the host computer, or reply to a request sent by the host computer.

All messages must use a carriage return (CR) as the end-of-line delimiter. Use your communications software on the host computer to assign a CR to the  key.

### Message Syntax

The information presented in this section applies to all RS-232 messages. The RS-232 message syntax uses the following conventions:

<b>bold</b>	Messages that you must enter exactly as shown in the manual. Do not include any spaces in the message string.
<i>italics</i>	Placeholder that represents text or numeric values that you must supply.
response	Format of message sent from the 670 controller.
<input type="text" value="ENTER"/>	Represents Carriage Return (CR) that must be configured as the end-of-line delimiter (in your communications software).

### Commands

A *command* message sent to the 670 instrument instructs it to perform a task or change a setting. All commands sent to the 670 instrument must have the following format:

**@parameter id data**

where:	<b>parameter</b>	is two ASCII bytes representing the command parameter
	<i>id</i>	is a single ASCII byte identifying the specific channel or relay, or a '0' if the command is neither a channel nor relay command
	<i>data</i>	is a variable length ASCII field representing the new value for the parameter

Refer to Table 21, page 90, Table 22, page 92, and Table 23, page 96, for a list of commands.

## Requests

A *request* message sent to the 670 instrument causes it to send back information. All requests sent to the 670 instrument use the same basic format as commands:

@**parameter** *id* ?

where:

<b>parameter</b>	is two ASCII bytes representing the command parameter
<i>id</i>	is a single ASCII byte identifying the specific channel or relay, or a 0 if the command is neither a channel nor relay command
?	is a '?' to request the current setting of the parameter

---

**Note**  The *data* entry is a ? to identify the message as a request rather than a command.

---

## Responses

All RS-232 messages sent to the 670 instrument initiate a response.

### *Response to a Command*

The response to a command will follow the format listed below:

status parameter id data <CR>

where:

status	'@' command accepted
	'>' parameter value is unrecognized
	'?' data field value invalid
	'=' command is inappropriate
parameter	is identical to the parameter field of the command received
id	is identical to the id field of the command received
data	is identical to the data field of the command received

---

**Note**  The *parameter*, *id*, and *data* fields in the response will be identical to the *parameter*, *id*, and *data* fields contained in the command received by the 670 instrument.

---

Table 20, page 88, shows the response and the cause for rejected commands.

Responses for Rejected Commands	
Response	Cause
?parameter data	Invalid data field
>parameter data	unrecognized <i>parameter</i> or identifier <i>id</i>
=parameter data	Command is inappropriate at this time

Table 20: Responses for Rejected Commands

The response to an accepted command will be identical to the command itself.

### ***Response to a Request***

The response to a request will follow the format listed below:

```
status parameter id data <CR>
```

where:

status	'@' indicates valid data
	'>' parameter value is unrecognized
	'?' data field value invalid
	'=' request is inappropriate
parameter	is identical to the parameter field of the request received
id	is identical to the id field of the request received
data	contains the data requested

### ***Example: Response to A Report Reading Request***

The response to a request to report the pressure reading (02) will have the following format, if accepted:

```
@020 status reading <CR>
```

where:

status	'space' where <i>space</i> represents one blank space if reading is valid
	'!' if the 670 instrument is calibrating
	"" if the pressure reading is underranged
	'#' if the pressure reading is overranged

### **Note**



---

The *parameter* and *id* fields in the response will be identical to the *parameter* and *id* fields contained in the request received by the 670 instrument. The *data* field in the response will contain the current value of the parameter or mode specified by the *parameter* field.

---

## RS-232 Messages

The RS-232 messages are divided into the following groups:

- Group I     requires no specific ID (*id* = '0')
- Group II    requires a channel ID (*id* = '0' for channel 1, '1' for channel 2, '2' for channel 3)
- Group III   requires a trip point ID (*id* = '0' for Trip Point A, '1' for Trip Point B)
- Group IV    diagnostic information

---

**Note**

To request the status of a parameter, enter the command for the parameter with a question mark inserted as the data field.

---

This section discusses the RS-232 commands used to implement features of the 670 instrument. Refer to *Chapter Four: Functional Overview*, page 43, for a complete description of the software features.

## Global Messages

The Global messages, listed in Table 21, do not use the <id> entry, however you must enter a '0' in the <id> entry field to complete the message string. The table lists the <data> entry for a command and a request.

@parameter 0 data

Global Messages			
Parameter Entry	Action	Data for a Command	Data for a Request
00	Active Channel	0 = Channel 1 1 = Channel 2 2 = Channel 3	'?'
01	Mode	0 = Pressure 1 = Zero 2 = Null 3 = Full Scale 4 = System Check	'?'
02	Report Reading	<i>Request Only</i>	'?'
03	Calibrate Mode	None	<i>Command Only</i>
04	Enable RS-232 Averaging	0 = No 1 = Yes	'?'

Table 21: RS-232 Global Messages

### Example 1: How To Set the Active Channel

- To set the active channel to Channel 2 (with a 274 multiplexer connected), send the command:

@0001

The 670 instrument will return the same command to indicate that the command was accepted and implemented. In addition, it will illuminate the light in the [Ch 2] key.

### Example 2: How To Request the Pressure Reading

- Issue the following command to set the 670 instrument in the pressure reading mode:

@0100

- To request the pressure reading issue the following query:

@020?

If the transducer is open to the atmosphere and Torr is selected as the pressure units, the response will be:

@020 760

### **Example 3: How To Calibrate the Null Value**

Calibrating the 670 instrument involves two Global commands. First, use the set mode (01) command to select the calibration procedure. Second, issue the calibrate mode (03) command to actually perform the calibration procedure.

#### **Note**



1. The remote zero feature requires an additional step. Refer to page 95 for an example explaining how to use the remote zero feature.
2. The time required to complete a calibration procedure depends on the value of the averaging entry. Refer to Table 16, page 73, for more information.

1. Use the set mode command to select the null calibration procedure:

@0102

The 670 instrument will return the same command to indicate that the command was accepted.

2. Send the calibrate mode (03) command to initiate the null calibration procedure:

@030

The front panel will flash the message “CALIBRATING” during the null calibration procedure. The system will send back the same command to indicate that the command was accepted. It does *not* send notification when the calibration is complete.

3. Change the mode back to pressure by sending the command:

@0100

### Channel-Specific Messages

The Channel-Specific messages, listed in Table 22, require the *id* entry to identify the channel:

**@parameter *id* data**

where *id* = 0 for Channel 1  
 = 1 for Channel 2  
 = 2 for Channel 3

Channel-Specific Messages			
Parameter Entry	Action	Data for a Command	Data for a Request
10	Display and Remote Reading Resolution	0 = 3.5 1 = 4.5 2 = 5.5	'?'
11	Response Time	0 = 1 msec 1 = 40 msec 2 = 400 msec	'?'
12	Enable Heater	0 = No (Off) 1 = Yes (On)	'?'
13	Pressure Unit	0 = Torr 1 = mmHg 2 = mbar 3 = Pa 4 = kPa 5 = psi 6 = inHg 7 = in H <sub>2</sub> O 8 = cm H <sub>2</sub> O 9 = % FS 10 = ppm 11 = mTorr	'?'
14	Temperature Compensation	ASCII number from 0 to 999 (500 disables the feature)	'?'
15	Sensor Full Scale	ASCII number	'?'
16	Number of Readings to Average	ASCII integer from 1 to 100	'?'

Table 22: RS-232 Channel-Specific Messages  
 (Continued on next page)

Channel-Specific Messages ( <i>Continued</i> )			
Parameter Entry	Action	Data for a Command	Data for a Request
17	Gain Range Mode	0 = x1 1 = x0.1 2 = x0.01 3 = Auto	‘?’
18	Enable Zero	0 = No (Off) 1 = Yes (On)	‘?’
19	Heater Current	<i>Request Only</i>	‘?’

Table 22: RS-232 Channel-Specific Messages

**Example 1: How To Change the Pressure Units**

To change the pressure units to psi on Channel 1, send the following command:

**@1305**

The 670 instrument will return the same command to indicate that the command was accepted.

**Example 2: How To Set the Display and Remote Reading Resolution**

To set the display and remote reading resolution to 4.5 digits on Channel 1, send the command:

**@1001**

The 670 instrument will return the same command to indicate that the command was accepted. The pressure reading, reported by the 020 command, will be in 4.5 digits.

**Example 3: How To Set the Sensor Full Scale Value**

Use the following command to set the sensor full scale to 0.1 Torr on Channel 2 (assuming that you have a 274 multiplexer connected to the 670 instrument):

**@151.1**

The 670 instrument will return the same command to indicate that the command was accepted. The pressure reading will now reflect the new sensor full scale range.

**Note**

The 670 instrument will accept fractional entries with or without the leading zero. For example, you may enter either “@1510.1” or “@151.1” as the full scale value.

**Example 4: How To Request the Heater Current**

The enable heater (12) command allows you to toggle the transducer heater on or off. In addition, the 670 unit can report the percentage of power used. You cannot change the power consumption.

1. Issue the following command to turn on the transducer heater (assuming that you have a heated transducer connected to the 670 instrument) on Channel 1:

@1201

The 670 instrument will return the same command to indicate that the command was accepted.

2. To determine the heater current send the command:

@190?

For example, if the heater current is at 55% of full power, the response will be:

@19055

**Example 5: How To Use Averaging**

The 670 instrument provides the capability to average multiple data points. You must issue the enable RS-232 averaging (04) command to use this feature for the RS-232 readings. Use the averaging period (16), to determine the number of points to average. Refer to *Averaging*, page 51, for a complete description of the averaging feature.

1. Issue the following command to enable RS-232 averaging on Channel 1:

@0401

2. To set the number of points to average to 10 on Channel 1, enter:

@16010

The 670 instrument will return the same command to indicate that the command was accepted.

**Note**

---

Be careful not to enter a decimal point in the number of points to average entry. The entry must be a *whole number*, from 1 to 100.

---

**Example 6: How To Zero the 670 Instrument**

Zeroing the 670 instrument involves two Group I commands and one Group II command. First, issue the enable remote zero (18) command to enable the zero operation. Second, use the set mode (01) command to select the calibration procedure. Third, send the calibrate mode (03) command to initiate the calibration procedure.

**Note**

---

The time required to complete a calibration procedure depends on the value of the averaging entry. Refer to Table 16, page 73, for more information.

---

The following example will zero the transducer on Channel 1.

1. Issue the following command to enable the remote zero operation:

**@1801**

2. Use the set mode command to select the zero procedure:

**@0101**

The 670 instrument will return the same command to indicate that the command was accepted and implemented.

3. Send the calibrate mode (03) command to initiate the zero procedure:

**@030**

The front panel will flash the message “CALIBRATING” while the instrument performs the zero function. The system will send back the same command to indicate that the command was accepted. It does *not* send notification when the calibration is complete.

4. Change the mode back to pressure by sending the command:

**@0100**

## Trip Point Messages

The Trip Point messages, listed in Table 23, require the <id> entry to identify the trip point:

**@parameter id data**

where: *id* = 0 for Trip Point A  
           = 1 for Trip Point B

Refer to *The [TRIP POINTS] Key*, page 54, for a complete description of the trip points.

Trip Point Messages			
Parameter Entry	Action	Data for a Command	Data for a Request
40	High Trip Point	ASCII number ranging from -105% to +105% of transducer full scale	'?'
41	Low Trip Point	ASCII number ranging from -105% to +105% of transducer full scale	'?'
42	Trip Point Hysteresis	ASCII number from 0 to 10 (used as a % of trip point value)	'?'
43	Relay Normal Configuration	0 = De-energized 1 = Energized	'?'
44	Trip Point Channel	0 = Channel 1 1 = Channel 2 2 = Channel 3	'?'
45	Latch Mode	0 = Disabled 1 = Enabled	'?'

Table 23: RS-232 Trip Point Messages

### Example 1: How To Configure the Trip Point Values

- To set the trip point high value for TP A to 900, issue the following command:

**@400900**

The 670 instrument will return the same command to indicate that the command was accepted and implemented.

- To set the trip point low value for TP A to 450, issue the following command:

**@410450**

**Example 2: How To Set the Trip Point Hysteresis**

The hysteresis value is defined as a  $\pm$  percent of the trip point value and can range from 0 to 10%. Refer to *How To Adjust Hysteresis*, page 78, for a complete discussion of hysteresis.

To set the hysteresis value for TP B to 0.1%, enter:

@421.1

The 670 instrument will return the same command to indicate that the command was accepted.

**Note**

---

The 670 instrument will accept fractional entries with or without the leading zero. For example, you may enter either “@4210.1” or “@421.1” as the hysteresis value.

---

**Example 3: How To Set the Trip Point Channel**

To set the trip point channel for TP A to Channel 3 (assuming that you have a 274 multiplexer connected to the 670 instrument):

@4402

The 670 instrument will return the same command to indicate that the command was accepted.

**Note**

---

The 670 instrument allows you to select Channels 2 and 3 even if the 670 is *not* connected to a 274 multiplexer. This enables you to configure the 670 instrument in one location and then insert it into a system with a 274 multiplexer, without modification.

---

## Diagnostic Messages

The Diagnostic messages, listed in Table 24, consist of one command (80) to provide diagnostic information. The <id> field identifies the diagnostic information requested.

<b>Diagnostic Messages</b>			
<b>Parameter Entry</b>	<i>Id</i>	<i>Data</i>	<b>Response</b>
80	0 = Request Answer Back	?	*U*U*U (produces an alternating bit pattern)
	1 = Request Version Number	?	Version number
	2 = I/O Connector Response	8-bit output image ? 16-bit input image	Produces the 8-bit output image at the I/O connector 16-bit input image
	3 = Report Actual Gain Range	?	0 = x1 1 = x 0.1 2 = x 0.01

Table 24: RS-232 Diagnostic Messages

### *Example 1: How To Check the Version Number*

To check the version number, send the following query:

@801?

The 670 instrument will respond with:

@801X.X

where X.X represents the actual version number.

**Example 2: How To Test the Output Signals on the I/O Connector**

This diagnostic test allows you to set the values of the output signals on the I/O connector. Use a voltmeter to read the value of the signals at the connector to detect any problem. This command controls the 8 outputs on the I/O connector. Table 25 lists the output bit number assignments and the bit values. To determine the connector value, add the bit values of the bits you wish to pull low. A value of 255 will set all the outputs low. Enter the connector value as the <data> field in the command string.

1. Calculate the connector value by adding the value of the bits you wish to pull low, in this case bits 3 (Channel 1 selected) and 5 (x1 range):

$$4 + 16 = 20 \leftarrow \text{Connector value}$$

↑
↑

Value of bit 3      Value of bit 5

2. Issue the following command:

@80220

3. Use a voltmeter to measure the output signals on pins 29 and 23 of the I/O connector. Each pin should be close to 0.00 V.

<b>I/O Connector Output Bit Number Assignments</b>			
<b>Diagnostic Output Bit Number</b>	<b>Bit Value</b>	<b>Function</b>	<b>I/O Pin Number</b>
1	1	Not Used	—
2	2	Not Used	—
3	4	<u>Select Channel 1</u> *	29
4	8	<u>Select Channel 2</u> *	28
5	16	<u>x1 Range ID</u>	23
6	32	<u>x0.1 Range ID</u>	19
7	64	<u>x0.01 Range ID</u>	18
8	128	Reserved	17
* The 274 multiplexer uses these pins select the active channel. Both pins 28 and 29 high when Channel 3 is the active channel.			

Table 25: I/O Connector Output Bit Assignment

**Example 3: How To Read the Input Signals on the I/O Connector**

This diagnostic command (802) allows you to read the input signals on the I/O connector. To perform this diagnostic test you will need to configure each input so you know the bit value of the connector. The I/O connector has 16 inputs. Table 26, page 101, lists the input bit number assignments and the bit values. A value of 65535 indicates that all the inputs are high. To determine the connector value, add the bit values of the bits you wish to pull low, and subtract that value from 65535.

1. Connect bit 7 (I/O pin 24) and bit 15 (I/O pin 10) to digital ground (I/O pin 4) to pull the inputs low.
2. To determine the value of the inputs read by the 670 instrument, issue the query:

**@802?**

3. The 670 instrument will respond with:

@80249087

To determine whether bits 7 and 15 are low, subtract the value of each bit from the total value of the connector:

$$65535 - (64 + 16384) = 49087$$

Connector value when all bits are high
Value of bit 7
Value of bit 15
Value returned by the 670 instrument

The value returned by the 670 instrument indicates that bits 7 and 15 are low.

I/O Connector Input Bit Number Assignments			
Diagnostic Input Bit Number	Bit Value	Function	I/O Pin Number
1	1	$\overline{10K}$	27
2	2	$\overline{1K}$	8
3	4	$\overline{100}$	26
4	8	$\overline{10}$	7
5	16	$\overline{1}$	25
6	32	$\overline{0.1}$	6
7	64	$\overline{x0.1 \text{ Select}}$	5
8	128	$\overline{x0.01 \text{ Select}}$	24
9	256	$\overline{\text{Channel 1 ID}}$	16
10	512	$\overline{\text{Channel 2 ID}}$	15
11	1024	$\overline{\text{Channel 3 ID}}$	14
12	2048	Reserved	13
13	4096	$\overline{\text{Remote Zero}}$	12
14	8192	Reserved	11
15	16384	$\overline{\text{Latch TP A}}$	10
16	32768	$\overline{\text{Latch TP B}}$	9

Table 26: I/O Connector Input Bit Assignment

**Example 4: How To Determine the Actual Range Used**

This message enables you to query the 670 instrument for the actual range in use. This may be useful when the 670 instrument is configured for autoranging. (The Channel-Specific query for the range will simply return “Auto” when the instrument is in autoranging.) Additionally, the 670 instrument changes the range during some calibration procedures so the actual range may differ from the range you selected. Once the calibration procedure is complete, it will return to the range selected before the calibration procedure was initiated.

This example assumes that the active range is x0.1.

- To check the actual range, send the following query:

**@803?**

The 670 instrument will respond with:

@8031

to indicate an active range of x0.1.

## Chapter Seven: IEEE-488 Communications Option

### General Information

**Note**

---

The information in this chapter only applies if your 670 instrument is configured with the IEEE-488 Communications option. If your 670 instrument is configured with the RS-232 communication option, refer to *Chapter Six, RS-232 Communications Option*, page 85, for remote communications information.

---

The IEEE-488 communications option complies with the ANSI/IEEE Standard 488.2 - 1992 (this standard encompasses the ANSI/IEEE Standard 488.1 - 1987).

### **Key Lock Switch**

To configure the 670 instrument to accept commands issued through IEEE-488 communications, place the Key Lock switch, located on the front panel, in the **REMOTE** position. While operating the 670 instrument in the **REMOTE** mode, the front panel controls are locked out and the display shows status information only. The 670 instrument expects to receive commands and instructions through the IEEE-488 communications or through the rear panel connectors. When the Key Lock switch is in the **LOCAL** position, the 670 instrument behaves in the opposite manner — it accepts commands from the front panel only and ignores commands issued by IEEE-488 communications or the rear panel connectors. Only status information is available through IEEE-488 communications.

Figure 6, page 31, shows the location of the Key Lock switch.

## IEEE-488 Device Compliance

Refer to Table 27 for a description of the IEEE-488 device compliant functions.

<b>IEEE-488 Device Compliance</b>		
<b>Function</b>	<b>Command</b>	<b>Compatibility</b>
Source Handshake	SH1	Complete
Acceptor Handshake	AH1	Complete
Talker	T6	Talker, serial poll and unaddress if my-listener-address (MLA)
Listener	L4	Listener and unaddress if my-talker-address (MTA)
Service Request	SR1	Can request (asynchronously) service from controller
Remote Local	RL0	No capability for lockout
Parallel Poll	PP0	No capability to send message without being addressed to talk
Device Clear	DC1	Complete
Device Trigger	DT0	No Capability
Controller	C0	Does not have the capability to send commands or addresses to other devices
Talker	TE0	Talker function with address extension not available
Listener	LE0	Listener function with address extension not available
Electrical Interface	E1	Open collector
<i>All the functions listed in this table are bus functions</i>		

Table 27: IEEE-488 Device Compliance

### Buffer Length

The buffer length is fixed at 256 characters.

### Address

Every device on the IEEE-488 bus must have an address assigned to it. To set the address of 670 instrument, scroll to the IEEE-488 configuration screen, under the [SETUP] key menu. The address entry ranges from 1 to 30. The 670 instrument is initially configured with the address set to 8.

## Status Information

The 670 instrument uses two software registers (defined by IEEE-488.2) to provide status information. The registers are the Standard Event Status register and the Status Byte register. The relationship of the registers is shown in Figure 17.

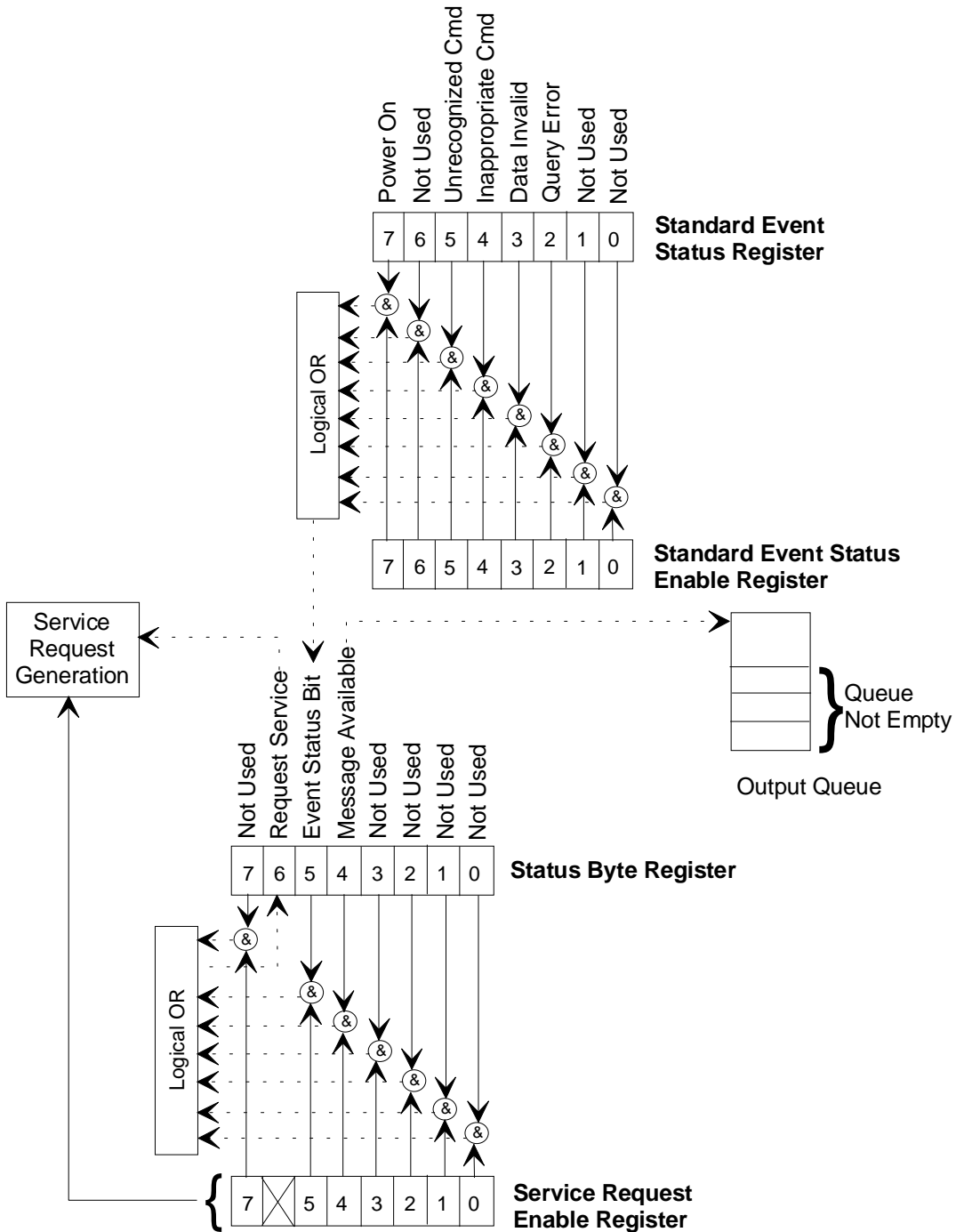

Figure 17: IEEE-488 Registers

### Standard Event Status Register

This register contains status information on the last communication (command) sent to the controller. The 670 instrument updates this register each time it receives a command.

Table 28 describes the function of this register.

<b>Standard Event Status Register</b>	
<b>Bit Number</b>	<b>Function</b>
7	Power On <i>Always set (value of 1) when the 670 unit is powered on</i>
6	Not Used*
5	Unrecognized Command
4	Inappropriate Command
3	Data Invalid
2	Set when query received and previous query not read
1	Not Used*
0	Not Used*
<i>* Will read as 0</i>	

Table 28: Standard Event Status Register

#### ***Standard Event Status Register Query (\*ESR?)***

Use this command to query the Standard Event Status register. If there is an error, this register may indicate what *type* of error has occurred.

### Status Byte Register

The Status Byte register contains information on the status of the 670 instrument. Bits 6, 5, and 4 are defined by IEEE-488.2. The information is useful to check the status of the instrument. To read the Status Byte register, issue the “\*STB?” command. Refer to Table 29 for a description of this register.

Status Byte Register	
Bit Number	Function
B7	Not Used*
B6	Master Summary Status bit. Set when service requested
B5	Set if Event Status Bit is set. Read Standard Event Status Register for status.
B4	Message available/Output Queue Not Empty
B3	Not Used*
B2	Not Used*
B1	Not Used*
B0	Not Used*
*Will read as 0	

Table 29: Status Byte Register

#### ***Read Status Byte Register Query (\*STB?)***

This command queries the status of the Status Byte register and the Master Summary Status bit (bit 6). The value of this register is placed in the output queue of the 670 instrument.

## Generating a Service Request

The 670 instrument can generate a Service Request (SRG) based on the status of the registers described above. A SRG alerts the host computer that the 670 instrument has encountered an error condition. To enable the 670 instrument to send a SRG, you must configure two enable registers: the Service Request Enable register (SRE) and the Standard Event Status Enable register (ESE). You can only read the status information of bits that have been enabled.

Commands for the Enable Registers		
Enable Register	Command to Set the Value	Command to Query the Value
Service Request Enable	“*SREdata”	“*SRE?”
Standard Event Status Enable	“*ESEdata”	“*ESE?”

Table 30: Commands for the Enable Registers

### *To Set the Value the Service Request Enable Register*

The “\*SREdata” command sets the value of the Service Request Enable register. For all bits except bit 6, a 1 indicates an enabled condition, and a 0 indicates a disabled condition. Bit 6 is not active and will always be 0.

### *To Set the Value the Standard Event Status Enable Register*

The “\*ESEdata” command sets the bits in the Standard Event Status Enable register. To clear the register, send the \*ESE command with a data value of 0, or cycle the power to the 670 instrument. The bits in this register are “enable” or “mask” bits for the Standard Event Status register. Setting a bit allows that bit (or status) to set a bit in the Status Byte register, listed in Table 29, page 107 (provided that B5 is set in the Service Request Enable).

## **IEEE-488 Messages**

The 670 instrument supports standard IEEE-488 messages, along with the MKS device dependent messages. The messages include both *commands* that instruct the 670 instrument to perform a task, and *queries* that request information from the 670 instrument.

---

**Note**

The IEEE-488 messages are *not* case sensitive. You may enter the commands in either upper- or lowercase.

---

### **Clear Status Command (\*CLS)**

The CLS command clears all status data structures and/or registers. The registers are SESR, OPERATION Status Register, QUESTIONABLE Status Register, and Error/Event Queue.

### **Operation Complete Messages**

The operation complete messages determine the status of an instrument, whether it is performing a task or idle.

#### ***Operation Command (\*OPC)***

The operation complete command is ignored since the 670 instrument executes only one command at a time.

#### ***Operation Complete Query (\*OPC?)***

Since the 670 instrument executes only one command at a time the response to an operation complete query is always complete and the query will return a value of 1.

### **Wait-to-Continue Command (\*WAI)**

The Wait-to-Continue command functions like a “no operation” command in the 670 instrument. The normal function of this command causes the instrument to stop executing commands until either the “no operation pending” state is true, or the 670 instrument is rebooted, or a Device Clear Active State (DCAS) message is received. Since the 670 instrument always processes messages sequentially, the “no operation pending” state is always true.

### Identification Query (\*IDN?)

The 670 instrument identifies itself in response to an identification query. The response includes the four fields listed in Table 31.

Identification Query Response		
Field	Information	Contents
1	Manufacturer	MKS Instruments
2	Model Number	MKS670BXXX
3	Reserved field	0
4	Firmware Level	x.x

Table 31: Identification Query Response

#### *Example: How To Check the Version Number*

- To check the version number, send the following command:

**\*IDN?**

The 670 instrument will respond with:

```
MKS Instruments MKS670BXXX 0 1.1x
```

where XXX represents the model number, and the last field contains the actual version number, in this example, version 1.1x.

### Reset Command (\*RST)

The reset command initializes to the 670 instrument. The initialization procedure includes Bus initialization and Message Exchange initialization. The reset command does not change the IEEE-488 address.

### Self-Test Query (\*TST?)

The self-test query performs an internal self-test and places a response in the Output queue to indicate whether the 670 instrument detected any errors during the self-test. A value of 0 is placed in the output queue when the self-test is completed successfully. A value of 1 indicates that the self-test has failed.

## MKS Device Dependent Messages

The IEEE-488 remote communications option allows you to operate the 670 instrument from an external IEEE-488 device, such as a computer equipped with a IEEE-488 communications board.

The messages are divided into *commands* that instruct the 670 instrument to perform a function or change a parameter, and *queries* that request information from the 670 instrument.

Responses sent by the 670 instrument reply to a query sent by the external IEEE-488 device. The 670 instrument does *not* send an acknowledgment message when it receives a command.

The device dependent commands are separated into four categories: global configuration commands, channel-specific configuration commands, trip point commands, and diagnostic commands.

### Note



1. The MKS device dependent messages are *not* case sensitive. You may enter the messages in either upper- or lowercase.
2. The 670 instrument does not send an acknowledgment message when it receives a command. This differs from the RS-232 protocol.

## Command Syntax

The commands and queries listed in this section use the following typographical conventions:

<b>bold</b>	Messages that you must enter exactly as shown in the manual. The 670 instrument ignores any spaces included in the message string.
<i>italics</i>	Placeholder that represents text of numeric values that you must supply.
response	Format of messages sent from the 670 instrument in response to a query.
	Represents the message termination character(s) that you may have to enter at the end of each message string. Normally, GPIB interface software programs expect a carriage return and line feed to indicate the end of a message. The GPIB message termination requirements are defined in the IEEE488.2 specification.

### Note



In general, the format for a query is the same as the command to set the entry, except that the value is replaced by a “?”.

## *Shortcut Commands and Queries*

The 670 instrument message protocol adheres to the format defined by Standard Commands for Programmable Instruments (SCPI) protocol although the commands and queries may not specifically meet the standards. This format allows you to enter either the entire message string or a shortcut version of the string. The following tables show both the full and the shortcut message string.

## Global Configuration Messages

The Global configuration messages include commands that define the operation of the 670 instrument and queries that request the status of a particular entry. These commands configure operating parameters that are used for all channels.

Global Messages	
Function	Message
Set the Active Channel  Command Shortcut command   Query Shortcut query	<b>:route:close(@ chan #)</b> <b>:rout:clos(@ chan #)</b>  where <i>chan #</i> equals: 1 for Channel 1 2 for Channel 2 3 for Channel 3  <b>:route:close?</b> <b>:rout:clos?</b>
Set the Mode  Command Shortcut command   Query Shortcut query	<b>:sense:function mode</b> <b>:sens:func mode</b>  <i>mode</i> equals (shortcut entry in parentheses): pressure (pres) zero syscheck (sysc) null fulscale (fuls)  <b>:sense:function?</b> <b>:sens:func?</b>
Report Reading  Command Shortcut command  <i>No query necessary</i>	<b>:measure:function</b> <b>:meas:func</b>  The 670 will report the reading in response to this command.

Table 32: IEEE-488 Global Messages  
(Continued on next page)

Global Messages ( <i>Continued</i> )	
Function	Message
Perform a Calibration Command Shortcut command	<b>:calibrate:function</b> <b>:cali:func</b>

Table 32: IEEE-488 Global Messages

***Example 1: How To Set the Active Channel***

To set the active channel to Channel 2 (assuming you have a 274 multiplexer connected), send the command:

**:route:close(@2)**

Channel 2 will become the active channel and its front panel LED will illuminate.

***Example 2: How To Request the Pressure Reading***

When using the 670 unit with a single transducer, the response to the report reading command will report data from Channel 1. If you are using the 670 unit with a 274 multiplexer, the response to the report reading command will report data from the active channel. Be sure that the active channel is the channel whose data you want *before* sending the report reading command.

1. To read the pressure on Channel 1, you must first send a command to set the 670 instrument in the pressure reading mode:

**:sense:function pressure**

2. To request the pressure reading, issue the following command:

**:measure:function**

If the transducer is open to the atmosphere and Torr is selected as the pressure units, the response will be:

measuring 760 <CR LF>

**Example 3: How To Calibrate the Null Value**

Calibrating the 670 instrument involves two steps. First, use the set mode command to select the calibration procedure. Second, issue the command to perform the calibration function to actually initiate the calibration procedure.

**Note**

- 
1. The zero feature requires an additional step. Refer to *Channel-Specific Messages*, page 115, for an example explaining how to use the zero feature.
  2. The time required to complete a calibration procedure depends on the value of the averaging entry. Refer to Table 16, page 73, for more information.
- 

1. Use the set mode command to select the null calibration procedure:

**:sense:function null**

2. Send the perform calibration command to initiate the null calibration procedure:

**:calibrate:function**

The front panel will flash the message “CALIBRATING” during the null calibration procedure. *Table 16: Relationship Between Averaging Entry and Calibration Times*, page 73, lists the approximate time for the null calibration.

3. Read the contents of the buffer to determine when the calibration is complete.
4. Change the mode back to pressure by sending the command:

**:sense:function pressure**

## Channel-Specific Messages

The Channel-Specific messages define the operation of a single channel on the 670 instrument. Channel 1 is always accessible. When the 670 instrument is connected to a 274 multiplexer, Channels 2 and 3 are accessible and should be configured. The queries cause the 670 instrument to report on the status of a particular entry.

In all the Channel-Specific messages, the channel number is shown as *chan #* . Enter the channel number as:

- 1 for Channel 1
- 2 for Channel 2
- 3 for Channel 3

Channel-Specific Messages	
Function	Message
Display and Remote Reading Resolution  Command Shortcut command  Query Shortcut query	<b>:sense:scan(@chan #):digit</b> <i>display resolution</i> <b>:sens:scan(@chan #):digi</b> <i>display resolution</i>  <b>:sense:scan(@chan #):digit?</b> <b>:sens:scan(@chan #):digi?</b>  where <i>chan #</i> equals 1, 2, or 3  where <i>display resolution</i> equals:  3.5 for 3.5 digit display and reading response 4.5 for 4.5 digit display and reading response 5.5 for 5.5 digit display and reading response
Response Time  Command Shortcut command  Query Shortcut query	<b>:sense:scan(@chan #):filter</b> <i>response time</i> <b>:sens:scan(@chan #):filt</b> <i>response time</i>  <b>:sense:scan(@chan #):filter?</b> <b>:sens:scan(@chan #):filt?</b>  where <i>chan #</i> equals 1, 2, or 3  where <i>response time</i> equals:  1MS for 1 millisecond 40MS for 40 millisecond 400MS for 400 millisecond

Table 33: IEEE-488 Channel-Specific Messages  
(Continued on next page)

<b>Channel-Specific Messages (Continued)</b>	
<b>Function</b>	<b>Message</b>
Enable Heater  Command Shortcut command  Query Shortcut query	<p><b>:route:control:heater(@chan #) State</b>  <b>:rout:cont:heat(@chan #) State</b></p> <p><b>:route:control:heater(@chan #)?</b>  <b>:rout:cont:heat(@chan #)?</b></p> <p>where <i>chan #</i> equals:            1 for Channel 1            2 for Channel 2            3 for Channel 3</p> <p>where <i>State</i> equals:             ON for On or enabled            OFF for Off or disabled</p>
Report Heater Current  Command Shortcut command	<p><b>:measure:heater (@chan #)</b>  <b>:meas:heat (@chan #)</b></p> <p>where <i>chan #</i> equals:            1 for Channel 1            2 for Channel 2            3 for Channel 3</p> <p>The 670 instrument will report the percentage of power used by the heater. (It does not require a query message.)</p>
Temperature Compensation  Command Shortcut command  Query Shortcut query	<p><b>:calculate:scan(@chan #):temcomp value</b>  <b>:calc:scan(@chan #):temc value</b></p> <p><b>:calculate:scan(@chan #):temcomp?</b>  <b>:calc:scan(@chan #):temc?</b></p> <p>where <i>chan #</i> equals:            1 for Channel 1            2 for Channel 2            3 for Channel 3</p> <p><i>value</i> is an ASCII number between 0 and 999, inclusive (value of 500 disables the feature)</p>

Table 33: IEEE-488 Channel-Specific Messages  
 (Continued on next page)

<b>Channel-Specific Messages (Continued)</b>	
<b>Function</b>	<b>Message</b>
Zero Enable  Command Shortcut command  Query Shortcut query	<p><b>:sense:scan(@chan #):zero state</b>  <b>:sens:scan(@chan #):zero state</b></p> <p><b>:sense:scan(@chan #):zero?</b>  <b>:sens:scan(@chan #):zero?</b></p> <p>where <i>chan #</i> equals:            1 for Channel 1            2 for Channel 2            3 for Channel 3</p> <p>where <i>state</i> equals:            ON (enabled)            OFF (disabled)</p>
Set Pressure Unit  Command Shortcut command  Query Shortcut query	<p><b>:sense:scan(@chan #):puni pressure unit</b>  <b>:sens:scan(@chan #):puni pressure unit</b></p> <p><b>:sense:scan(@chan #):puni?</b>  <b>:sens:scan(@chan #):puni?</b></p> <p>where <i>chan #</i> equals:            1 for Channel 1            2 for Channel 2            3 for Channel 3</p> <p>where <i>pressure unit</i> equals:            TORR (for Torr)            MMHG (for mmHg)            MBAR (for mbar)            PA (for Pa)            KPA (for kPa)            PSI (for psi)            INHG (for inHg)            INH2 (for inH<sub>2</sub>O)            CMH2 (for cmH<sub>2</sub>O)            PREC (for percent F.S.)            PPMF (for ppm)            MTOR (for mTorr)</p> <p>The response is in uppercase and contains the first four characters only. For example, inH<sub>2</sub>O is reported as INH2.</p>

Table 33: IEEE-488 Channel-Specific Messages  
 (Continued on next page)

<b>Channel-Specific Messages (Continued)</b>	
<b>Function</b>	<b>Message</b>
Sensor Full Scale  Command Shortcut command  Query Shortcut query	<pre><b>:sense:scan(@chan #):range value</b> <b>:sens:scan(@chan #):rang value</b>  <b>:sense:scan(@chan #):range?</b> <b>:sens:scan(@chan #):rang?</b></pre> <p>where <i>chan #</i> equals:</p> <ul style="list-style-type: none"> <li>1 for Channel 1</li> <li>2 for Channel 2</li> <li>3 for Channel 3</li> </ul> <p>where <i>value</i> is an ASCII number</p>
Set Averaging  Command Shortcut command  Query Shortcut query	<pre><b>:calculate:scan(@chan #):average value</b> <b>:calc:scan(@chan #):aver value</b>  <b>:calculate:scan(@chan #):average?</b> <b>:calc:scan(@chan #):aver?</b></pre> <p>where <i>chan #</i> equals:</p> <ul style="list-style-type: none"> <li>1 for Channel 1</li> <li>2 for Channel 2</li> <li>3 for Channel 3</li> </ul> <p>where <i>value</i> is an ASCII number from 1 to 100, inclusive</p> <p><b>Note:</b> An averaging entry of 1 effectively disables the averaging feature.</p>

Table 33: IEEE-488 Channel-Specific Messages  
(Continued on next page)

Channel-Specific Messages (Continued)	
Function	Message
Gain Range	
Command	<b>:sense:scan(@chan#):gain value</b>
Shortcut command	<b>:sens:scan(@chan#):gain value</b>
Query	<b>:sense:scan(@chan#):gain?</b>
Shortcut query	<b>:sens:scan(@chan#):gain?</b>
	where <i>chan #</i> equals: 1 for Channel 1 2 for Channel 2 3 for Channel 3
	where <i>value</i> equals X1, X0.1, X0.01, or Auto

Table 33: IEEE-488 Channel-Specific Messages

**Example 1: How To Change the Pressure Units**

To change the pressure units to psi on Channel 1, send the following command:

```
:sense:scan(@1):puni psi 
```

**Example 2: How To Set the Display and Remote Reading Resolution**

To set the display and remote reading resolution to 4.5 digits on Channel 1, send the command:

```
:sense:scan(@1):digit 4.5 
```

The 670 instrument will return the same command to indicate that the command was accepted. The pressure reading, reported by the “:measure:function” command, will be in 4.5 digits.

**Example 3: How To Set the Sensor Full Scale Value**

Use the following command to set the sensor full scale to 0.1 Torr on Channel 2 (assuming that you have a 274 multiplexer connected to the 670 instrument):

```
:sense:scan(@2):range 0.1 
```

The pressure reading will now reflect the new sensor full scale range.

**Note**

The 670 instrument will accept fractional entries with or without the leading zero. For example, you may enter either “0.1” or “.1” to set the full scale range.

**Example 4: How To Request the Heater Current**

The enable heater command allows you to toggle the transducer heater on or off. In addition, it will report the percentage of power used (when enabled). You cannot change the value.

1. Issue the following command to enable the transducer heater (assuming that you have a heated transducer connected to the 670 instrument) on Channel 1:

**:route:control:heater(@1) on**

2. To determine the heater current send the command:

**:measure:heater(@1)**

For example, if the heater current is at 55% of full power, the message will be:

55 <CR LF>

**Example 5: How To Zero the 670 Instrument**

Zeroing the 670 instrument involves one channel-specific command and two global configuration commands. First, issue the channel-specific command to enable the zero operation. Second, use the global configuration command, set mode, to select the calibration procedure. Third, send the command to perform the calibration to initiate the calibration procedure.

**Note**

---

The time required to complete a calibration procedure depends on the value of the averaging entry. The values are listed in Table 16, page 73.

---

The following example will zero the transducer on Channel 1.

1. Issue the zero enable command to enable the zero operation:

**:sense:scan(@1):zero on**

2. Use the set mode command to select the zero procedure:

**:sense:function zero**

3. Send the perform calibration mode command to initiate the zero procedure:

**:calibrate:function**

The front panel will flash the message “CALIBRATING” while the instrument performs the zero function. *Table 16: Relationship Between Averaging Entry and Calibration Times*, page 73, lists the approximate time for the zero calibration.

4. Change the mode back to pressure by sending the command:

**:sense:function pressure**

### Trip Point Messages

The Trip Point messages define the trip point values, both high and low, the initial state of the trip point relays, and the hysteresis values. Refer to *The [TRIP POINTS] Key*, page 54, for a complete description of the trip points.

Trip Point Messages	
Function	Message
Trip Point High Value  Command Shortcut command   Query: Shortcut query:	<b>:control:relay A or B:high TP value</b> <b>:cont:rela A or B:high TP value</b>  where <i>TP value</i> a number between $\pm 105\%$ of full scale  <b>:control:relay A or B:high?</b> <b>:cont:rela A or B:high?</b>
Trip Point Low Value  Command Shortcut command   Query: Shortcut query:	<b>:control:relay A or B:low TP value</b> <b>:cont:rela A or B:low TP value</b>  where <i>TP value</i> a number between $\pm 105\%$ of full scale  <b>:control:relay A or B:low?</b> <b>:cont:rela A or B:low?</b>
Hysteresis Value  Command Shortcut command   Query: Shortcut query:	<b>:control:relay A or B:hyst value</b> <b>:cont:rela A or B:hyst value</b>  where <i>value</i> is a $\pm$ percent of the trip point, from 0 to 10% (applied to the trip point value)  <b>:control:relay A or B:hyst?</b> <b>:cont:rela A or B:hyst?</b>
Trip Point Normal State  Command Shortcut command   Query: Shortcut query:	<b>:control:relay A or B:norm state</b> <b>:cont:rela A or B:norm state</b>  where <i>state</i> equals: ener for energized dent for de-energized  <b>:control:relay A or B:norm?</b> <b>:cont:rela A or B:norm?</b>

Table 34: IEEE-488 Trip Point Messages  
(Continued on next page)

Trip Point Messages ( <i>Continued</i> )	
Function	Message
Trip Point Channel Command Shortcut command Query: Shortcut query:	<b>:control:relay A or B:trip (@ tp chan)</b> <b>:cont:rela A or B:trip (@ tp chan)</b>  <b>:control:relay A or B:trip?</b> <b>:cont:rela A or B:trip?</b>  where <i>tp chan</i> equals: 1 for Channel 1 2 for Channel 2 3 for Channel 3
Latch Mode Command Shortcut command Query: Shortcut query:	<b>:control:relay A or B:latch state</b> <b>:cont:rela A or B:latch state</b>  <b>:control:relay A or B:latch?</b> <b>:cont:rela A or B:latch?</b>  where <i>state</i> equals: enab for enabled disa for disabled

Table 34: IEEE-488 Trip Point Messages

**Example 1: How To Configure the Trip Point A Value**

To set the TP A high value to 900, issue the following command:

```
:control:relay a:high 900 
```

**Example 2: How To Set the Trip Point Hysteresis**

The trip point hysteresis value is defined as a  $\pm$  percent of the trip point value and can range from 0 to 10%. Refer to *How To Adjust the Hysteresis*, page 78, for more information.

To change the hysteresis value to 2% for TP B, enter:

```
:control:relay b:hyst 2 
```

**Note**

The 670 instrument will accept fractional entries with or without the leading zero. For example, you may enter either “0.1” or “.1” to set the hysteresis value.

***Example 3: How To Set the Trip Point Channel for Trip Point A***

To set TP A channel to Channel 1, issue the following command:

**:control:relay a:trip (@1)**

***Example 4: How To Set the Latch Mode for Trip Point A***

To enable the latch mode for TP B, issue the following command:

**:control:relay b:latch enab**

## Diagnostic Messages

The Diagnostic messages help to troubleshoot a problem with the 670 instrument. The messages in this category enable you to read the value of the input bits and define the value of the output bits on the I/O connector.

Diagnostic Messages	
Function	Message
Set the Output Bits on the I/O Connector  Command	<b>:cont:out</b> <i>value</i>  Refer to Table 25, page 99, for a list of the I/O connector output pins.
Read the Value of the Input Bits on the I/O Connector  Query	<b>:cont:in?</b>  where <i>value</i> is an ASCII number from 0 to 65535(16 bits)  Refer to Table 26, page 101, for a list of the I/O connector input pins.

Table 35: IEEE-488 Diagnostic Messages

### Example 1: How To Test the Output Signals on the I/O Connector

This diagnostic test allows you to set the values of the output signals on the I/O connector. Use a voltmeter to read the value of the signals at the connector to detect any problem. This command controls the 8 outputs on the I/O connector. Table 25, page 99, lists the output pins, the output bit number assignments, and the bit values. To determine the connector value, add the bit values of the bits you wish to pull low. A value of 255 will set all the outputs low. Enter the connector value as the <data> field in the command string.

1. Calculate the connector value by adding the value of the bits you wish to pull low, in this case bits 3 (Channel 1 selected) and 5 (x1 range):

$$4 + 16 = 20 \leftarrow \text{Connector value}$$

↑
↑

Value of bit 3      Value of bit 5

2. Send the following command:

**:cont:out 20** ENTER

3. Use a voltmeter to measure the output signals on pins 29 and 23 of the I/O connector. Each pin should be close to 0.00V.

**Example 2: How To Read the Input Signals on the I/O Connector**

To perform this diagnostic test you will need to configure each input so you know the bit value of the connector. The I/O connector has 16 inputs. Table 26, page 101, lists the input bit number assignments and their bit values. A value of 65535 indicates that all the inputs are high. To determine the connector value, add the bit values of the bits you wish to pull low, and subtract that value from 65535.

1. Connect bit 7 (I/O pin 24) and bit 15 (I/O pin 10) to digital ground (I/O pin 4) to pull the inputs low.
2. To determine the value of the inputs read by the 670 instrument, issue the query:

**:cont:in?**

3. The 670 instrument will respond with:

40987 <CR LF>

To determine whether bits 7 and 15 are low, subtract the value of each bit from the total value of the connector:

$$65535 - (64 + 16384) = 49087$$

Connector value when all bits are high
Value of bit 7
Value of bit 15
← Value returned by the 670 instrument

The value returned by the 670 instrument indicates that bits 7 and 15 are low.

This page intentionally left blank.

## Chapter Eight: Maintenance and Troubleshooting

### **General Information**

Periodically check for wear on the cables and inspect the enclosure for visible signs of damage. The only maintenance required on the 670 instrument is to change the fuses.

### **How To Clean the Unit**

Periodically wipe down the unit with a damp cloth. Do not use any solvents to clean the unit.

## How To Replace the Fuses

To replace the fuses:

1. Select the proper fuses.

All units have two fuses installed to *fuse both sides* of the line. The fuse values, marked on the rear panel, are:

- 100 to 120 VAC = 0.63 Amperes Time-Lag Type
- 200 to 240 VAC = 0.315 Amperes Time-Lag Type

Refer to Table 36 for a description of the fuses. To change the line voltage selection, refer to *How To Change the Line Voltage Selection*, page 82.

Fuses for the Type 670 Instrument		
Voltage Selector Setting	Nominal Line Voltage Range	Fuse Type
115 VAC	100 to 120 VAC @50/60 Hz 75 VA (max)	0.63A (T), 250 V, 5 x 20 mm
230 VAC	200 to 240 VAC @50/60 Hz 75 VA (max)	0.315A (T), 250 V, 5 x 20 mm

Table 36: Fuses for the Type 670 Instrument

### Note



The fuses are IEC rated (where the name plate value is the expected current *carrying* rating) and not UL or CSA rated (where the name plate value is nearly the current *blowing* rating). Use of UL or CSA rated fuses will cause unnecessary blowing at high loads.

Appropriate replacement fuses include:

- Bussmann GDC-T315 mA or equivalent for the 0.315 A fuse
- Bussmann GDC-T630 mA or equivalent for the 0.63 A fuse

2. Disconnect the power cord from the 670 instrument.

**Warning**

---

**To avoid an electrical shock, be sure to disconnect the power cord *before* proceeding.**

---

3. Disconnect all cables from the connectors located on the back of the unit.
4. Insert a small, flat head screw driver under one side of the black fuse holder, then the other, to disengage the fuse holder.  
The fuse holder will slide partially out of the instrument.
5. Carefully slide the fuse holder out and remove the fuse.
6. Insert the new fuse into the fuse holder.  
Be certain that the new fuse is the appropriate type for the line voltage selection.
7. Slide the fuse holder back into the Power Entry module.  
Be sure to snap the fuse holder completely into the instrument.
8. Connect any cables removed from the back of the 670 instrument in step 3 above.
9. Connect the power cord.

## **Troubleshooting**

This section describes the most common problems encountered with the 670 instrument and offers possible solutions.

---

**Note**

If possible, substitute another similar instrument to verify that the problem involves the 670 instrument *before* proceeding.

---

### ***Noisy Pressure Reading***

- Verify that all cable connections on the 670 instrument are screwed in securely.
- Check the pressure system to ensure that all connections are tight.
- Isolate any mechanical vibration from the pressure transducer with bellows.
- Use the averaging feature to average multiple pressure readings.  
Refer to *Averaging*, page 51, for discussion of the averaging feature.
- Use cables designed for high EMI environments.

### ***Trip Point Relays Change State Erratically***

- Verify that all connections are tight.
- Verify that the High and Low values are entered correctly for each trip point.  
Refer to *How To Configure the Trip Points*, page 75, for more information.
- Check the hysteresis value.  
Refer to *How To Adjust Hysteresis*, page 78, for an explanation of the hysteresis entries.

***Overrange (>10.5 Volts) Pressure Readings***

1. Verify that all vacuum fittings are tight and that the transducer is properly pumped down below its resolution.

Low range absolute transducers (100 mmHg and below) will be overranged at atmospheric pressure.

2. Connect another meter, either analog or digital, to the output to verify that the display of the 670 instrument is operating correctly.
3. Press the [SETUP] key on the front panel of the 670 instrument.  
The system responds by displaying the setup parameters.
4. Repeatedly press an arrow key, ( [△] or [▽] ), until the pressure units screen appears.
5. Use the Adjust knob to select mmHg as the pressure units.
6. Press the [CAL] key to enter the calibration screen.
7. Press an arrow key, ( [△] or [▽] ), until the system check screen appears.

Ch 1	9.8799 Volts
SYSCHK	

The SYSCHK reading should be between 9.5 and 10.5 Volts. A SYSCHK value outside this range, indicates a problem with the pressure transducer or its cable.

8. Perform the steps outlined in the flow chart in Figure 18, page 132.

### Troubleshooting Chart

Before continuing to use the troubleshooting chart, verify that all vacuum fittings are tight and that the transducer is properly pumped down below its resolution. Low range absolute transducers (100 mmHg and below) will be overranged at atmospheric pressure.

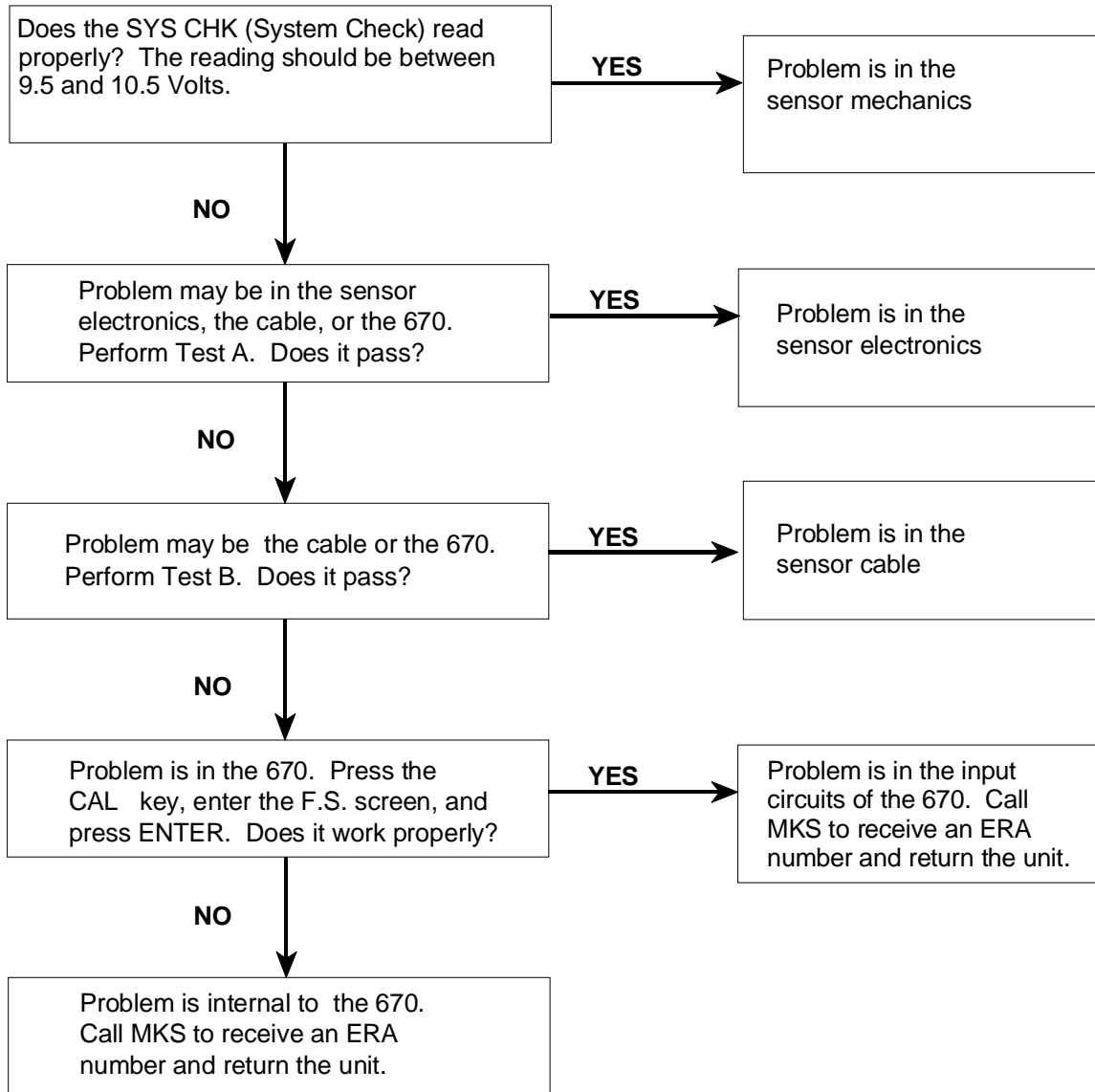



Figure 18: Troubleshooting Flow Chart



**Test A: Localizing Malfunction to the Cable or the Electronics Unit*****Equipment Required:***

Digital Volt Meter (DVM)

1. Disconnect the transducer cable from the transducer.
2. Press the [CAL] key on the front panel of the 670 instrument.  
The system responds by displaying the calibration screen.
3. Press an arrow key, (  or  ), until the system check screen appears.

Ch 1	9.8799 Volts
SYSCHK	

The reading should be between 9.5 and 10.5 Volts. A reading outside this range indicates a problem with the pressure transducer or its cable.

4. Press the [SETUP] key.  
The system responds by displaying a setup screen.
5. Repeatedly press an arrow key, (  or  ), until the Heater screen appears.

Ch 1	Heater OFF
------	------------

6. Use the Adjust knob to turn the heater OFF.
7. Press the [ENTER] key to turn off the heater.  
The system responds by turning off the heater.

- Use the DVM to check the voltages at the transducer end of the cable.

Refer to Table 37 for the appropriate voltage values. Reference the DVM to pin H (2).

Transducer Cable Voltage Check		
Transducer Cable Pin Number	Voltage	Function
I or (13)	+12 to +13	Transducer electronics supply voltage
D or (14)	+12 to +13	System Check command
J or (15)	6 Volts RMS	Excitation voltage
<i>Note that some transducer cables use numbers while others use letters.</i>		

Table 37: Transducer Cable Voltage Check

- Connect two resistors to the transducer cable, as shown in Figure 19.

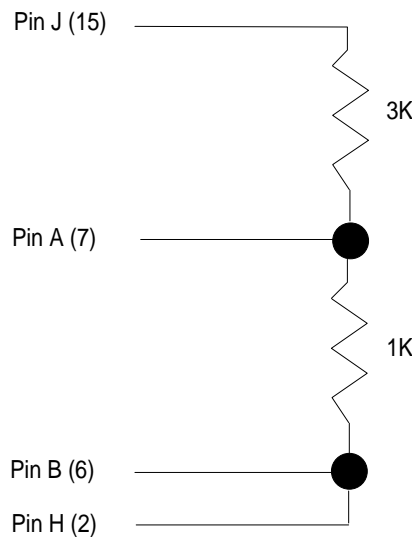

Figure 19: Two Resistors Added to the Transducer Cable

- Press the [CAL] key to enter the calibration menu.

The system responds by displaying the calibration screen.

11. Press an arrow key, (  or  ), until the system check screen appears.

Ch 1	-9.8799 Volts
SYSCHK	

This should produce a negative full scale reading,  $\pm 10\%$ .

12. Connect a short circuit across the 1K resistor and press the [x0.01] range selection key.

The system responds by changing to the x0.01 range.

13. Press the [ZERO] key on the 670 instrument front panel.

The system responds by displaying the zero screen.

14. Use the Adjust knob to select ON for the zero enable entry.

15. Press the [ENTER] key to start the zeroing process.

You should be able to adjust this control  $\pm 40\%$  of full scale.

**Test B: Localizing Malfunctions to the Electronics Unit**

1. Disconnect the transducer cable from the 670 instrument and check voltages at the Head (upper) connector on the Signal Conditioner Board.

<b>Electronics Unit Voltage Check</b>		
<b>Connector Pin</b>	<b>Voltage</b>	<b>Function</b>
13	+12 to +13	Transducer electronics supply voltage
14	+12 to +13	System Check command
15	6 Volts RMS	Excitation voltage

Table 38: Electronics Unit Voltage Check

2. Repeat step 5 of Test A at the transducer connection.  
The results should be the same.

## Appendix A: Product Specifications

*All specifications are at 23° C, 120 VAC*

### Performance Specifications

Ranges	x1, x0.1, and x0.01 of full range of the pressure transducer
Analog Signal Output	
Voltage available at rear connector	0 to $\pm 10$ V on each range (x1, x0.1, x0.01), into $>10K$ ohm load
Impedance	$<1$ ohm
Temperature Coefficient (x1 range)	
Zero	$\pm 4$ ppm of range/ $^{\circ}$ C (without calibration)
Span	$\pm 25$ ppm of range/ $^{\circ}$ C (without calibration) $\pm 15$ ppm of range/ $^{\circ}$ C (with full scale calibration)
Accuracy <sup>1</sup>	
Zero	
x1	$\pm 100$ ppm of range F.S.
x0.1	$\pm 100$ ppm of range F.S.
x0.01	$\pm 200$ ppm of range F.S.
Span	
x1	$\pm 300$ ppm of range F.S.
x0.1	$\pm 350$ ppm of range F.S.
x0.01	$\pm 800$ ppm of range F.S.
Linearity	
0 to +10 Volts	$<\pm 25$ ppm F.S.
0 to -10 Volts	$<\pm 50$ ppm F.S.
Noise	
0.01 - 0.4 Hz	$< 70$ $\mu$ Volts peak-to-peak, on the x1 and x0.1 ranges $< 350$ $\mu$ Volts peak-to-peak, on the x0.01 range
1 kHz - 1 MHz	$<4$ mV peak-to-peak, on all ranges

<sup>1</sup> Includes non-repeatability

**Performance Specifications (Continued)**

Display and Digital Communications Accuracy Zero Span Update Rate Linearity 0 to 10 Volts 0 to -10 Volts Pressure Units Temperature Coefficient Zero Span	 $\pm 50$ ppm F.S. $\pm 200$ ppm F.S. 4 times per second (every 0.25 seconds) $<\pm 15$ ppm of F.S. $<\pm 50$ ppm of F.S. Torr, mmHg, mbar, Pa, kPa, psi, inHg, inH <sub>2</sub> O, cmH <sub>2</sub> O, % of Full Scale, ppm, mTorr  1 ppm/ <sup>o</sup> C 25 ppm/ <sup>o</sup> C
CE Compliance Electromagnetic Compatibility <sup>2</sup> Low-Voltage Product Safety and Liability Installation Category Pollution Degree	 Electromagnetic Compatibility Directive 89/336/EEC Low-Voltage Directive 73/23/EEC Product Safety Directive 92/59/EEC II, according to EN 61010-1 2, according to IEC 664

---

<sup>2</sup> An overall metal braided shielded cable, properly grounded at both ends, is required during use.

## Physical Specifications

Connectors	
I/O	37-pin Type “D”, female
Head (upper connector on the Signal Conditioner Board)	15-pin Type “D”, female
Signal (lower connector on the Signal Conditioner Board)	9-pin Type “D”, male
Remote Communications	
Serial Interface	9-pin Type “D”, male
IEEE-488	24-pin IEEE/488.1 compliant, female
Remote Communications	RS-232C or IEEE-488.2
Trip Points	Two trip points, each controlling a relay, with front panel LED indicator lights.
Contact ratings	24 Volts AC/DC @ 1 Amp resistive
High trip points	Activated when the input pressure signal equals, or exceeds, the high trip point level
Low trip points	Activated when the input pressure signal equals, or falls below, the low trip point level
	De-activated between the high and low trip points
Relay state	User selectable — energized or de-energized
Action	An activated relay will change state and the front panel LED will illuminate
Dimensions	3½”H x 9½”W x 9”D <i>Standard MKS ½ rack</i> (8.9 cm H x 24.1 cm W x 22.9 cm D)
Weight	7 lbs. 14 oz. ( 3.6 kg)

**Environmental Specifications**

Operating Temperature Range	15 to 40° C (59 to 104° F)
Humidity Range	10 through 90% non-condensing

**Electrical Specifications**

Power Requirement	100 to 120 or 200 to 240 VAC @ 50 - 60 Hz, 75 VA maximum
Fuses	
100 to 120 VAC	0.63A (T), 250 V, 5 x 20 mm
200 to 240 VAC	0.315A (T), 250 V, 5 x 20 mm

Due to continuing research and development activities, these product specifications are subject to change without notice.

## Appendix B: Model Code Explanation

### Model Code

The options of your 670 instrument are identified in the model code when you order the unit.

The model code is identified as follows:

**670BXXX**

where:

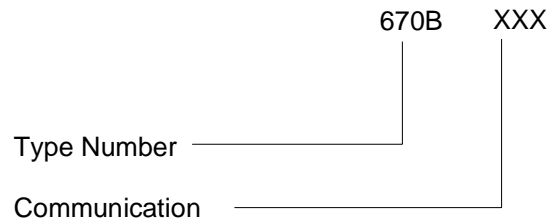

#### **Type Number (670B)**

This designates the model number of the instrument.

#### **Communication (XXX)**

The communication option, either RS-232 or IEEE-488, is specified by a three character code.

<b>Communication</b>	<b>Ordering Code</b>
RS-232	D21
IEEE-488	D81

This page intentionally left blank.

## Appendix C: Initial Settings

### General Information

The 670 signal conditioner is shipped with the following initial configuration. This configuration is *not* a default configuration, however, since the 670 unit stores most of the configuration settings in non-volatile RAM. Settings stored in non-volatile RAM are saved when the power is turned off. When the power is restored, the 670 unit “remembers” the latest configuration, not the initial configuration. Refer to Table 39 for a complete list of the initial configuration settings. The last column lists the page number for information on each entry, should you wish to change the setting.

<b>Initial Settings</b>			
<b>Parameter</b>	<b>Default</b>	<b>Options</b>	<b>Page</b>
Display Size	5½	4½, 3½	45
Response	400	1, 4	46
Pressure Units	Torr	mmHg, mbar, Pa, kPa, psi, inHg, inH <sub>2</sub> O, cmH <sub>2</sub> O, % full scale, ppm, mTorr	48
Heater Current Display	Off	On	47
Temperature Compensation	0	User selectable, from 0 to 999	50
Sensor Range	10	User selectable	49
Averaging	20	User selectable, from 1 to 99	51
RS-232 Communication	Baud: 9600 Data Bits: 8 Parity: No End-of-line: CR	300, 1200, 2400, 4800 7 Even, Odd No option	85
IEEE-488 Address	8	1 to 30	53
Zero Enable	On	Off	62
Autoranging	Off	On	64

Table 39: Initial Settings  
(Continued on next page)

<b>Initial Settings (Continued)</b>			
<b>Parameter</b>	<b>Default</b>	<b>Options</b>	<b>Page</b>
Trip Points, A and B			
High	+105.000%	User selectable	55
Low	-105.000%	User selectable	55
Hysteresis	±0.10%	User selectable	56
State	Energized	De-energized	58
Latch	Disabled	Enabled	58
Channel	1	2, 3 if connected to a Type 274 multiplexer	59
Line Voltage	115 VAC	230 VAC	82

Table 31: Initial Settings

## Appendix D: Interface Cables for a Type 274 Multiplexer

### I/O Connector Cables

When the 670 instrument is interfaced with a 274 multiplexer, two cables connect the two units. First, a CB270-2 cable must connect the Head connector (upper connector on the Signal Conditioner board) to the ELEC connector on the 274 unit. Second, the I/O connector must be connected to the DVM connector on the 274 unit, by *either* a CB670-1 or CB670-2 cable. The CB670-1 is a straight cable, so the cable pins match the pinout listed in Table 9, page 37. The CB670-2 is a Y-cable that allows access to the trip point relays and remote functions included on the I/O connector.

#### **CB670-2 Y Cable**

Cable CB670-2 consists of one 37-pin male connector (P1) that connects to the I/O connector on the 670 instrument, one 25-pin male connector (P2), and one 25-pin female connector (P3). Table 40, page 146, lists the pinout of the 25-pin male connector. Table 41, page 147, lists the pinout of the 25-pin female connector. The trip point relays and the remote functions are available on the 25-pin female connector.

---

**Note**

There is no internal connection on the pins assigned a “No Connection” function.

---

<b>Pinout of the Y-Cable 25-pin Male Connector</b>	
<b>Pin</b>	<b>Signal</b>
1	$\overline{\text{Special}}$
2	$\overline{10K}$
3	$\overline{1K}$
4	$\overline{100}$
5	$\overline{10}$
6	$\overline{1}$
7	No Connection
8	$\overline{\text{Channel 1 ID}}$
9	$\overline{\text{Channel 2 ID}}$
10	$\overline{\text{Channel 3 ID}}$
11	Channel ID Common
12	$\overline{\text{Select Channel 1}}$
13	$\overline{\text{Select Channel 2}}$
14	No Connection
15	No Connection
16	No Connection
17	No Connection
18	No Connection
19	No Connection
20	No Connection
21	No Connection
22	Digital Ground
23	No Connection
24	No Connection
25	No Connection

Table 40: Pinout of the Y-Cable 25-pin Male Connector

<b>Pinout of the Y-Cable Female Connector</b>	
<b>Pin</b>	<b>Signal</b>
1	Trip Point A NC
2	Trip Point A Common
3	Trip Point A NO
4	Trip Point B NC
5	Trip Point B Common
6	Trip Point B NO
7	$\overline{\text{Latch TP A}}$
8	$\overline{\text{Latch TP B}}$
9	$\overline{\text{Remote Zero}}$
10	Analog Ground
11	Pressure Output
12	$\overline{\text{X0.01 Select}}$
13	$\overline{\text{X0.1 Select}}$
14	$\overline{\text{X1 Range ID}}$
15	$\overline{\text{X0.1 Range ID}}$
16	$\overline{\text{X0.01 Range ID}}$
17	Digital Ground
18	Power Ground
19	No Connection
20	No Connection
21	No Connection
22	Digital Ground
23	No Connection
24	No Connection
25	No Connection

Table 41: Pinout of the Y-Cable 25-pin Female Connector

This page intentionally left blank.

## Index

### A

Addressing, 104  
AUTO key, 64–65  
Autoranging, 64–65  
Averaging, 51, 72, 73, 94

### B

Baratron, 17, 22  
Buffer length, 104

### C

Cables, 23, 54, 58, 67, 69, 134, 145  
Calibrating, with the Type 274, 74  
Calibration delays, 73  
CE compliance, 138  
Channel indicator lights, 32  
Companion products, 22  
Connecting, Type 274, 74  
Customer support, 20

### D

Default configuration, 143  
Dimensions, 28  
Display screen, 44  
Display size, 45

### E

Environmental requirements, 27

### F

Front panel controls, 31–32, 43  
Full scale, configuring, 60, 71, 73, 119  
Fuse information, 128

### H

Heater current, 47, 81, 94, 120  
Hysteresis, 56, 57, 78, 97  
    adjusting, 56

### I

I/O connector, 36, 63, 80, 99, 100, 124, 145  
IEEE-488 communications, 141  
    address, 104  
    buffer length, 104  
    cables, 24, 34  
    connector, 35  
    device compliance, 104  
    messages, 109–10  
    parameters, 53  
Initial settings, 143  
Input power, 27  
Installation Category, 27  
Interface cables, 23, 54, 58, 67, 69, 134, 145

### K

Key Lock switch, 31, 34, 35, 85, 103

### L

Line voltage, 82

- Local mode, 31
- M**
- Manual
- conventions, 19
  - organization, 18
- Model code, 141
- N**
- Null calibration, 60
- O**
- Optional accessories, 22
- P**
- Pollution Degree, 27
- Power entry module, 40
- Pressure output signal, 36, 51
- Pressure units, 48, 49, 71, 119
- Product location requirements, 27
- R**
- Range, 79
- Range selection keys, 32
- Remote mode, 31, 34, 35, 79, 85, 103
- Remote zero, 63, 80
- Response setting, 46, 52, 72
- Returning the product, 21
- Returns, 20
- RS-232 communications, 141
- cables, 24, 34
  - connector, 34
  - parameters, 53, 85
  - responses, 87
- S**
- Safety information, 1–16
- Sensor range, 49
- Serial number, 41
- Settings, initial, 143
- SETUP key, 85
- Signal Conditioner board, 38
- Signal connector, 36, 39
- Software version, 81, 98
- System Check reference, 61, 83, 131, 132
- T**
- Temperature, 27
- Temperature compensation, 36
- Trip point, 96
- Trip points, 32, 36, 54–59, 96–97, 121–23, 130
- action, 54
  - channel selection, 58
  - configuring, 54, 75
  - disabling, 77
  - hysteresis, 56, 57
  - latch, 36, 58, 59, 77
  - relay state, 57
- Type 274 multiplexer, 22, 23, 32, 36, 45, 47, 49, 50, 54, 58, 63, 69, 115
- Type 274, connecting, 22, 74
- U**
- Units, 48, 49, 71, 119
- Unpacking checklist, 21

**V**

Version, 81, 98

**Z**

Zero, 73

Zero, configuring, 62, 74, 95, 120

