



HPS® Square Body LoPro Series

Bellows Sealed Poppet Valves

***OPERATION AND
MAINTENANCE MANUAL***



HPS® Square Body LoPro Series

Bellows sealed Poppet Valves

May 1999
PART #100010482

Part # ___ - _____

Please fill in these numbers and have them readily available when calling for service or additional information.

(The part number is located on the label attached to a cable of the heater.)

For more information or literature, contact:

Vacuum Products Group of MKS Instruments, Inc.
5330 Sterling Drive
Boulder, CO 80301 USA

Phone: 303-449-9861
800-345-1967

FAX: 303-442-6880

© 1999 by Vacuum Products Group of MKS Instruments, Inc. All rights reserved.

ALCONOX is a registered trademark of Alconox, Inc.
IgniTorr is a trademark of HPS™ Division of MKS Instruments, Inc.
Inconel is a registered trademark of Inco Alloys International, Inc.
Scotch-Brite is a trademark of 3M.
SensaVac is a registered trademark of MKS Instruments, Inc.

Table of Contents

Table of Contents

1. Package Contents	1
1.1 IN THIS MANUAL	1
1.2 Symbols Used in this Manual	1
2. Safety Precautions	2
Modification	2
Maintenance	2
Hazardous Materials	2
Installation	2
Operation	2
3. Description of LoPro Valves	3
4. Operating Principles	5
4.1 Pneumatic Version	5
4.1.1 Pneumatic Cycling	5
4.1.2 Limit Switch Actuation	7
4.1.3 Solenoid Operated Pilot Valve Operation	8
4.2 Manual Version	9
4.2.1 Manual Cycling	9
5. Specifications	11
5.1 Environment	11
5.1.1 Installation Orientation	11
5.1.2 Applied Forces	11
5.1.3 Temperature Extremes	11
5.2 Operation & Performance	13
5.2.1 Cycle Rate and Life	13
5.2.1.1 Pneumatic Actuation	13
5.2.1.2 Manual Actuation	13
5.2.2 System Pressure Limits	13
5.2.3 Pneumatic Pressure Limits – Pneumatic Actuation Only	14
5.2.4 Pneumatic Flow–Pneumatic Actuation Only	14
5.2.5 Limit Switch Ratings– Pneumatic Actuation Only	14
5.2.6 Solenoid Duty Cycle and Power Requirements	14
5.3 Dimensions	15
5.3.1 Dimensions – Manual Actuation	15
5.3.2 Dimensions – Pneumatic Actuation	17
5.3.3 Weight	19
6. Installation Information	20
6.1 Pneumatic Supply– Pneumatic Actuation Only	20
6.2 Electrical Connections– Pneumatic Actuation Only	20
6.3 Clean Installation	21
6.4 Flange Care	21

7.3 Actuator Assembly - Manual Version	23
7.3.1 Actuator Assembly Removal and Disassembly	23
7.3.2 O-Ring Replacement	24
7.3.3 Actuator Assembly Installation	24
7.4 Limit Switches - Pneumatic Actuation Only	25
7.4.1 Limit Switch Removal	25
7.4.2 Limit Switch Installation	25
7.4.3 LS Retrofit	25
7.5 Solenoid Pilot Valve Service - Pneumatic Actuation Only	26
7.6 Replacement Parts List	28
8. Trouble Shooting	29
8.1 Problems and Diagnosis Pneumatic Actuation	29
8.1.1 Won't close completely	29
8.1.2 Won't open completely	29
8.1.3 Opens slowly or in jumps	29
8.1.4 Won't open at all	30
8.1.5 Squeaks When opening and /or closing	30
8.1.6 Leaks across closed nosepiece seal	30
8.1.7 Leaks from atmosphere when closed	30
8.1.8 Leaks from atmosphere when open	31
8.1.9 Leaks from atmosphere at all times	31
8.1.10 Air leaks from around piston when open	31
8.1.11 Air leaks from vent hole while opening	31
8.1.12 Air leaks from vent hole when open	31
8.1.13 Limit switches not sending signals	31
8.1.14 Solenoid valve buzzes or doesn't work	31
8.2 Problems and Diagnosis Manual Actuation	32
8.2.1 Won't close completely	32
8.2.2 Won't open completely	32
8.2.3 Difficult to open/close or Squeaks	32
8.2.4 Leaks across closed nosepiece seal	32
8.2.5 Leaks from atmosphere when closed	32
8.2.6 Leaks from atmosphere when open	33
8.2.7 Leaks from atmosphere at all times	33
8.3 Causes and Remedies	33
8.3.1 Spring failure - Pneumatic Actuation Only	33
8.3.2 Body damage	33
8.3.3 Port flange damage	33
8.3.4 Particulates, condensation, and corrosion	34
8.3.5 Bellows failure	34
8.3.6 Nosepiece seal failure	34
8.3.7 Bonnet seal failure	34
8.3.8 Piston seal failure - Pneumatic Actuation Only	34
8.3.9 Stem seal failure - Pneumatic Actuation Only	35
8.3.10 Bonnet seal omission	35
8.3.11 Nosepiece seal omission	35
8.3.12 Improper assembly	35
8.3.13 Loose piston hold down screw - Pneumatic Actuation Only	35
8.3.14 Inadequate Lubrication	36
8.3.15 Inadequate air pressure - Pneumatic Actuation Only	36
8.3.16 Inadequate air flow - Pneumatic Actuation Only	36
8.3.17 Limit switch failure - Pneumatic Actuation Only	37
8.3.18 Solenoid valve failure - Pneumatic Actuation Only	37
8.3.19 Stem Weld Failure	37

7. SERVICE	22
7.1 Removal from System	22
7.1.1 Pneumatic Version	22
7.1.2 Manual Version	22
7.2 Actuator Assembly – Pneumatic Version	23
7.2.1 Actuator Assembly Removal and Disassembly	23
7.2.2 O-Ring Replacement	23
7.2.3 Actuator Assembly Installation	24
7.3 Actuator Assembly – Manual Version	24
7.3.1 Actuator Assembly Removal and Disassembly	24
7.3.2 O-Ring Replacement	25
7.3.3 Actuator Assembly Installation	25
7.4 Limit Switches – Pneumatic Actuation Only	26
7.4.1 Limit Switch Removal	26
7.4.2 Limit Switch Installation	26
7.4.3 LS Retrofit	26
7.4.4 Limit Switch Adjustment	27
7.5 Solenoid Pilot Valve Service – Pneumatic Actuation Only	27
7.6 Replacement Parts List	29
8. Trouble Shooting	30
8.1 Problems and Diagnosis Pneumatic Actuation	30
8.1.1 Won't close completely	30
8.1.2 Won't open completely	30
8.1.3 Opens slowly or in jumps	30
8.1.4 Won't open at all	31
8.1.5 Squeaks when opening and/or closing	31
8.1.6 Leaks across closed nosepiece seal	31
8.1.7 Leaks from atmosphere when closed	31
8.1.8 Leaks from atmosphere when open	32
8.1.9 Leaks from atmosphere at all times	32
8.1.10 Air leaks from around piston when open	32
8.1.11 Air leaks from vent hole while opening	32
8.1.12 Air leaks from vent hole when open	32
8.1.13 Limit switches not sending signals	32
8.1.14 Solenoid valve buzzes or doesn't work	32
8.2 Problems and Diagnosis Manual Actuation	33
8.2.1 Won't close completely	33
8.2.2 Won't open completely	33
8.2.3 Difficult to open/close or Squeaks	33
8.2.4 Leaks across closed nosepiece seal	33
8.2.5 Leaks from atmosphere when closed	33
8.2.6 Leaks from atmosphere when open	34
8.2.7 Leaks from atmosphere at all times	34
8.3 Causes and Remedies	34
8.3.1 Spring failure – Pneumatic Actuation Only	34
8.3.2 Body damage	34
8.3.3 Port flange damage	34
8.3.4 Particulates, condensation, and corrosion	35
8.3.5 Bellows failure	35
8.3.6 Nosepiece seal failure	35
8.3.7 Bonnet seal failure	35
8.3.8 Piston seal failure – Pneumatic Actuation Only	35
8.3.9 Stem seal failure – Pneumatic Actuation Only	36
8.3.10 Bonnet seal omission	36
8.3.11 Nosepiece seal omission	36
8.3.12 Improper assembly	36
8.3.13 Loose piston hold down screw –	36
8.3.14 Inadequate lubrication	36

8.3.15 Inadequate air pressure – Pneumatic Actuation Only	37
8.3.16 Inadequate air flow – Pneumatic Actuation Only	37
8.3.17 Limit switch failure – Pneumatic Actuation Only	37
8.3.18 Solenoid valve failure – Pneumatic Actuation Only	37
8.3.19 Stem Weld Failure	38
9. RETURN TO FACTORY FOR REPAIR OR SERVICE	39
9.1 Call the factory	39
9.2 Prepare for shipment	39
10. Product Warranty	40
11. Notes	42

1. Package Contents

1.1 IN THIS MANUAL

This manual details functional information for the non-heated HPS® Square Body LoPro Series, angle and in-line bellows sealed poppet valves, their options and accessories. HPS® also offers a Square Body LoPro heated valve line, the Jalapeno LoPro Series. For more information on the Jalapeno LoPro series refer to Jalapeno LoPro instruction manual.

Inspect the Square Body LoPro for visible evidence of damage during shipment. If it has been damaged, notify the carrier immediately. Keep all shipping materials and packaging for claim verification. Do not return the Product to HPS®.

MKS Instruments, Inc.
Vacuum Products Group
5330 Sterling Dr.
Boulder, CO. 80301
USA



Telephone (303) 449-9861
Toll-Free (800) 345-1967 (USA only)
Facsimile (303) 449-2003

1.2 Symbols Used in this Manual

The first two symbols below, that may be located on your HPS® Square Body LoPro Series, identify critical safety concerns. They are used throughout this manual to further define the safety concerns associated with the product.



CAUTION: Risk of electrical shock.



CAUTION: Refer to manual. Failure to heed message could result in personal injury or serious damage to the equipment or both.

The last two symbols identify other information in this manual that is essential or useful in achieving optimal performance from the PDR 9000.



Failure to heed message could result in damage to the equipment.



Calls attention to important procedures, practices, or conditions.

2. Safety Precautions

Modification



Unauthorized modification of the product voids the warranty and may affect its operation. Contact HPS® Applications Engineering Department for more information on customizing your valve.

Maintenance



Install only HPS® replacement parts or their equivalents following the procedures detailed in section 7.

Hazardous Materials



If hazardous materials are used, users must take responsibility to observe the proper safety precautions and insure that the material used is compatible with those from which the valve is fabricated.

Installation



All flanges and fittings interfacing with the valve must be consistent with those on the valve. Assemble and tighten vacuum flanges and pneumatic fittings according to standards and carefully check for leaks prior to operation. Pneumatic valves with solenoid pilot valves and/or limit switches should be properly grounded.

Operation



Keep fingers, clothing, hair, and other intrusive materials away from the valve ports during operation. Never exceed the upper limits for internal or pneumatic pressure. If equipped with solenoid pilot valve or limit switches, do not operate in explosive atmospheres.

3. Description of LoPro Valves

HPS® Square Body LoPro valves are pneumatically or manually operated bellows sealed poppet valves, designed for compact size, lightweight, and long life.

Internal actuation in the pneumatic version of the Square Body LoPro valve is controlled by a pneumatic cylinder attached directly to the top of the valve. The valve is opened when pneumatic pressure is supplied to the bottom of this cylinder. When the air is vented, the valve is closed by an internal spring. In the event of a power or pneumatic failure, the valve returns to its closed position.

Internal actuation in the manual version of the Square Body LoPro valve is controlled by a knob located on the top of the valve. The valve is opened when the knob is turned counter clockwise to the topped out position. The valve is closed when the knob is turned clockwise to the bottomed out position.

The bodies of both the pneumatic and manual versions of the valve are available in angle and concentric in-line configurations with a variety of flanging. Custom body configurations and flange combinations are available upon request.

O-rings function as face seals on the bonnet and nosepiece, while a metal bellows is used to seal the moving poppet. O-rings are available in a variety of elastomers.

Optional limit switches for the remote indication of open and closed positions are available for the pneumatic version only. These limit switches are mounted on the top of the cylinder and are directly actuated by a cam extending from the upper end of the stem.

A solenoid operated pneumatic pilot valve may, optionally, be installed in the pneumatic version only. This pilot valve allows electrical control of the Square Body LoPro valve while it is connected directly to the facility pneumatic supply. Solenoid valves are available in a variety of voltages.

Figure 1 Summarizes the options available for the Square Body LoPro Series.

Figure 1 Square Body LoPro Valve Options

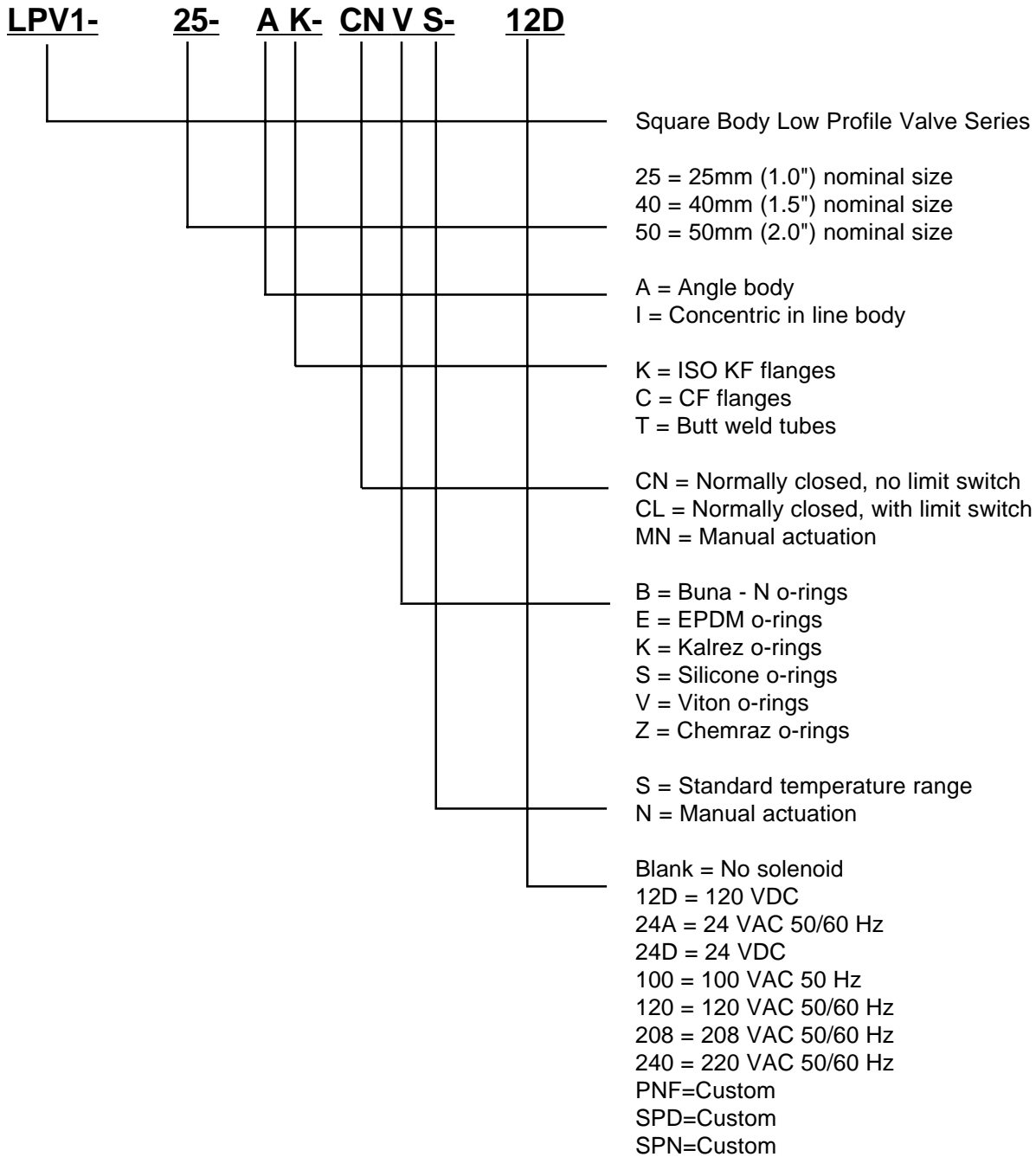

4. Operating Principles

4.1 Pneumatic Version

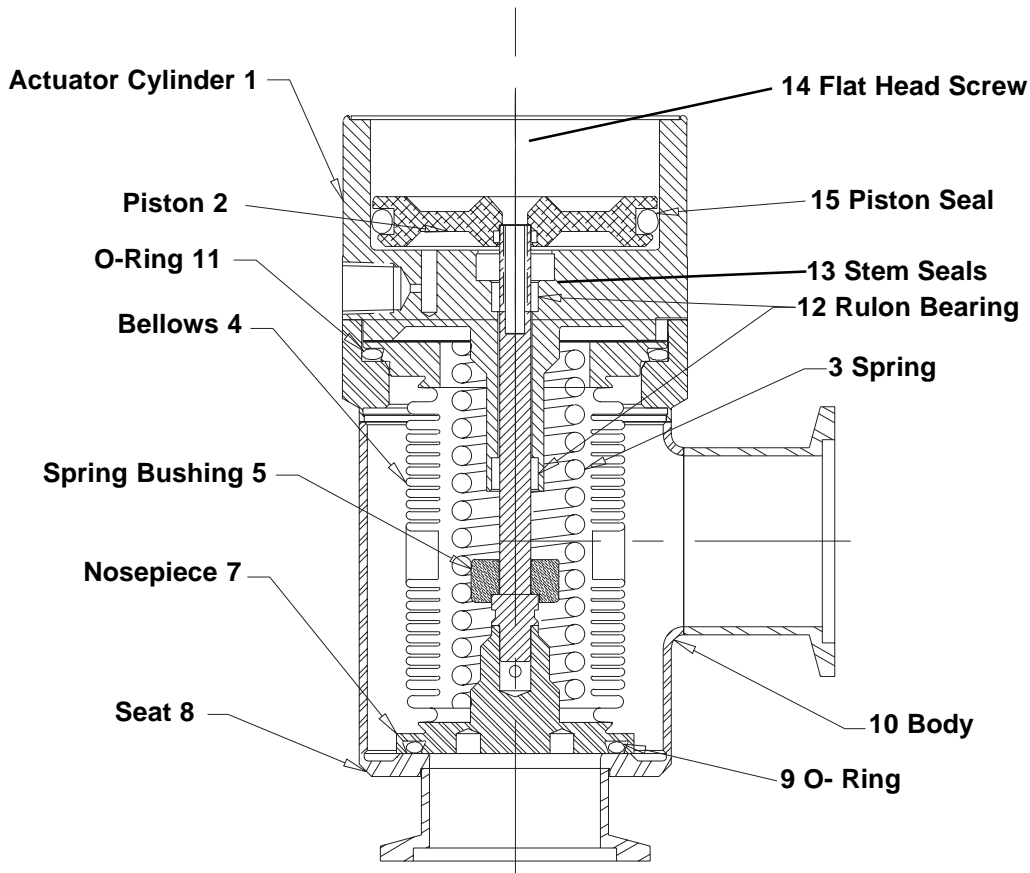

Figure 2 - Pneumatic operation

4.1.1 Pneumatic Cycling

Figure 2 illustrates the components of the pneumatic valve. From its normally closed position, the valve is opened with the admission of compressed air to the pneumatic cylinder through the 1/8" female NPT port in the side of the cylinder (1).

When the pneumatic pressure in the cylinder reaches a value sufficient to overcome the force of the spring (3), the piston (2) starts to rise, pulling the nosepiece (7) off of the seat (8). The stem (6) is attached to the piston with a flat head screw (14). The actuator cylinder is vented to allow air from within the bellows (4) to escape (and enter) as its volume changes. At the lower end of the stem, the nosepiece is welded to the stem. It carries an o-ring seal (9) in a trapezoidal groove, which, when squeezed between the nosepiece and the seat, effects the seal at the valve orifice. The bellows forms a flexible hermetic seal between the nosepiece and the fixed elements of the body (10).

As long as adequate pneumatic pressure is applied, the piston continues to travel upward, further compressing the spring, until the top of the nosepiece, spring bushing (5), and bottom of the cylinder are all in contact. This is the open position stop.

To close the valve, the cylinder is vented through the same 1/8" NPT port. As the air pressure falls below the value necessary to maintain compression on the spring at the open position stop, the piston and the nosepiece start to move towards the closed position. As venting continues, the nosepiece and seal reach the seat. After the valve is closed, full seal force is not attained until the cylinder has reached minimum (usually atmospheric) pressure.

4.1.2 Limit Switch Actuation

When a valve is equipped with limit switches, they are mounted on top of the cylinder as shown in **Figure 3**. When the valve is closed, the lever of the closed position switch (18) is depressed by the cam extension (17) on the top of the stem (6). When the valve is fully opened, the cam extension activates the lever of the open position switch (16).

Observing that the closed position limit switch is actuated does not necessarily verify that the valve is sealed leak tight, as contamination or damage to the seal or seat could affect seal integrity. It does confirm, however, that the valve, and its control, obeyed the command to move to the closed position.

Figure 3 - Limit switch operation

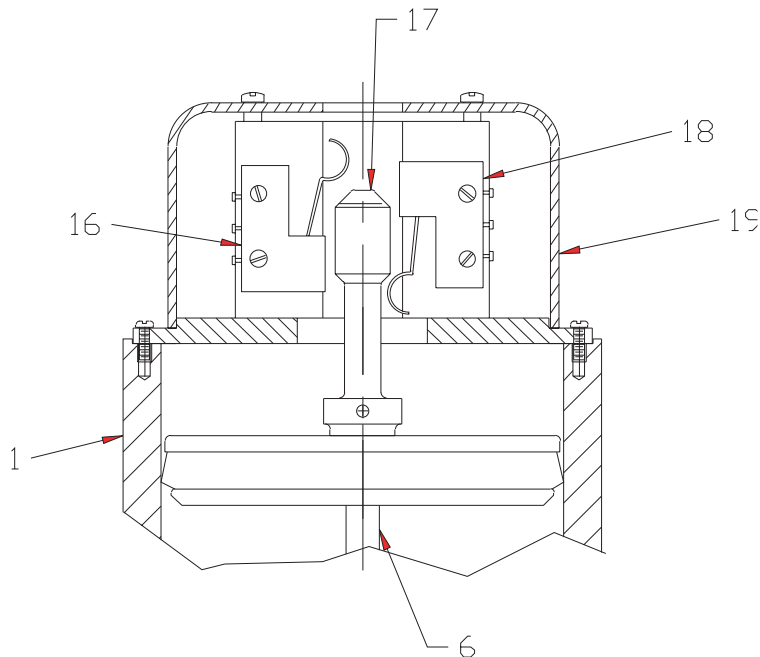

4.1.3 Solenoid Operated Pilot Valve Operation

Optional installation of a solenoid operated pneumatic pilot valve in the 1/8" female NPT port in the side of the cylinder (1), as shown in **Figure 4**, enables remote electrical control of the valve when direct pneumatic control is inconvenient. In its de-energized state, this 3-way valve vents the cylinder of the Square Body LoPro through a threaded hole centered in the top of the solenoid coil (20). A nipple (24) connects the 1/8" female NPT outlet port on the solenoid valve to the cylinder of the Square Body LoPro. The joints are sealed with an anaerobic pipe compound.

When power is applied, the magnetic field developed by the coil overcomes the force of the spring (22) and lifts the plunger (21) off the seat (23). While this opens a pressurized flow path from the pneumatic line connected to the 1/8" NPT inlet port, it also seals the venting flow path. Being at the vent port's pressure (usually, but not necessarily atmospheric), the cylinder of the valve is quickly pressurized and the valve opens (see section 3.1).

When power to the solenoid is turned off, the spring forces the plunger back to its original position, simultaneously closing the pressurized port and opening the vent port. Pressurized air in the cylinder of the valve quickly escapes through grooves on the outside of the plunger and out the vent port, allowing the valve to close (see section 3.1).

Users may supply their own solenoid operated pilot valve. A solenoid valve rated for $> 10^6$ cycles continuous duty and a conductance $> .05 \text{ in}^3/\text{min}$ is recommended. The lengths and diameters of pneumatic feed lines must also be considered for peak performance.

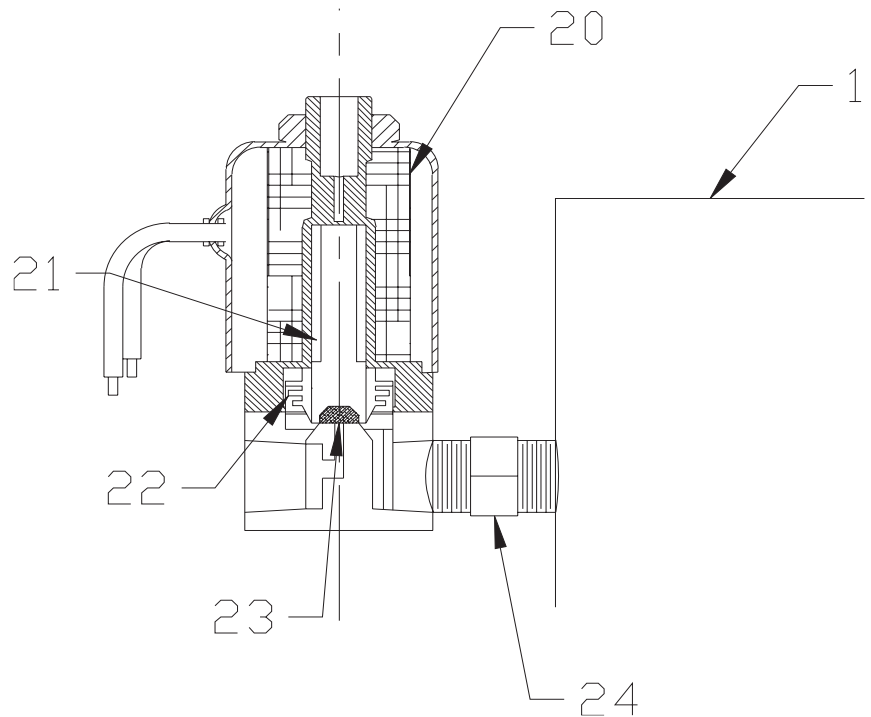

Figure 4 - Solenoid pilot valve

4.2 Manual Version

4.2 Manual Version

4.2.1 Manual Cycling

Figure 5 illustrates the components of the manual valve. From the closed position, the valve opens by twisting the manual knob counterclockwise, raising the manual screw in the manual stem guide thus lifting the nosepiece off of the seat. The manual stem guide has a vent to allow air from within the bellows to escape (and enter) as its volume changes. The top of the stem is attached to the manual screw via a pan head screw, while the bottom of the stem is welded to the nosepiece. The nosepiece carries an o-ring seal in a trapezoidal groove, which, when squeezed between the nosepiece and the seat, effects the seal at the valve orifice. The bellows forms a flexible hermetic seal between the nosepiece and the fixed elements of the body. The open position stop occurs when the top of the thrust bearing and the bottom of the stem guide are in contact.

To close the valve, simply turn the manual knob all the way in the clockwise direction. The valve is not closed until the nosepiece and seal are in contact with the seat and full seal pressure is applied.

Figure 5

LPV! - 25 Manual Actuation Angle KF

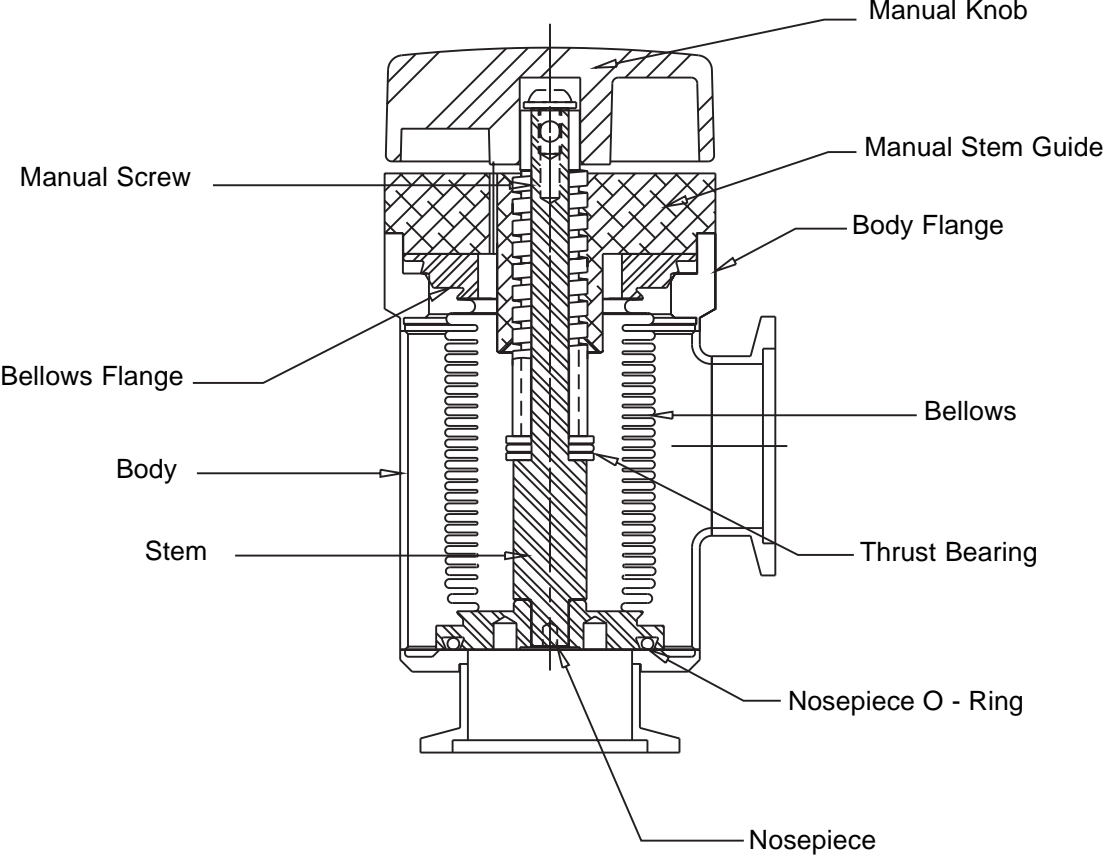

5. Specifications

5.1 Environment

5.1.1 Installation Orientation

Square Body LoPro Series valves function equally well installed in any orientation.

5.1.2 Applied Forces

As with any vacuum piping component, improper installation in the vacuum line may result in damage to the component. The strength of the Square LoPro body is roughly equivalent to an elbow of similar size. Care must be taken to protect the body of the Square LoPro from excessive stress buildup in the vacuum line. This problem may be avoided by the proper installation of flexible metal hose(s). The HPS® Applications Engineering department is available to help with such problems.

5.1.3 Temperature Extremes

The Square Body LoPro valve series is rated for service from -20°C to 93°C (standard manual version, pneumatic version without the optional limit switch package or solenoid operated pilot valve). In the pneumatic version, addition of the optional limit switch package decreases the upper temperature limit to 82°C, while adding the optional solenoid pilot valve increases the lower limit to 0°C.

The Square Body LoPro valve's most vulnerable components to temperature extremes are the organic compounds used in seals, bearings, and lubrication. In the pneumatic version, the pressurized cavity in the pneumatic cylinder is sealed by a pair of Parker PolyPak¹ Seals. These standard temperature range seals are rated for service from -51°C to 93°C². (Reference Figure 2, p.5 for Lopro intrnal schematic)

O-rings in Figure 2 seal the bonnet and poppet of the valve and are available in a variety of seal elastomers. These elastomers have the following recommended operating temperature ranges³:

Buna-N	-54°C to 135°C
Kalrez ⁴	-26°C to 260°C
Silicone	-114°C to 232°C
Viton ⁴	-26°C to 204°C

Excessive temperatures, especially in combination with dry air or gas, can cause o-rings and seals to dry out, harden, crack, or even melt, possibly resulting in a vacuum or pneumatic leak. However, because the transfer of

heat from/to the valve's pneumatic actuator assembly to/from the body and the nosepiece of the valve is relatively inefficient, the nosepiece o-ring may be subjected to significantly higher/lower temperatures without affecting the pneumatic seals. However, to avoid pneumatic seal damage, the cylinder temperature should be monitored in the presence of sustained extreme system or ambient temperatures.

The Rulon LR⁵ PTFE bearings supporting the stem are rated for service between -240°C and 287°C⁶. Lubricating greases used on the stem, piston seal, and manual screw increase their viscosity at low temperatures. This increase in viscosity increases the force required to move the poppet. Lighter fractions of these lubricants begin to evaporate at temperatures below 100°C, ultimately resulting in dried lubricant, increased friction on the sliding surfaces, and also increasing the force required to move the poppet. While the operating temperatures of these lubricants do not pose immediate problems, regular maintenance, with attention to the condition of the piston, stem and manual screw lubricants, should be performed on valves run for extended periods at or near the high temperature limit.

Similarly, the optional limit switch package contains polymers and elastomers in the switch housings and grommets. The temperature ratings for these components are as follows⁷:

Switches	-53°C to 85°C
grommets	-51°C to 82°C

The wire or cable connected to the limit switches and/or solenoid valve should be selected for use in the appropriate temperature range.

Optional solenoid operated pneumatic pilot valves also have organic compounds in their seals and in the insulation of the coil and lead wires. All Peter Paul solenoid valves normally supplied with Square Body LoPro valves are rated for operation between 0°C and 104°C.

1) Polypak is the registered trademark of the Parker Hannifin Corp.
2) PolyPak Seal Design Handbook, 2, (1989)
3) Parker O-Ring Handbook, A3-4 / A3-6, (1991)
4) Kalrez and Viton are the registered trademarks of E.I. du Pont de Nemours Co.
5) Rulon is the registered trademark of Kixon, Division of Furon
6) Guide to dexon Bearings D4
7) Courtesy of Microswitch Division of Honeywell Corp.

5.2 Operation & Performance

5.2.1 Cycle Rate and Life

5.2.1.1 Pneumatic Actuation

The opening and closing times are the limiting factors of the maximum cycle rate. If the valve is cycled faster than the sum of the opening and closing time, it will fail to open or close completely, possibly resulting in failure. Although opening and closing times are dependent upon the pneumatic pressure, flow available and other parameters, the following values represent the time for the poppet to move full stroke at median recommended pneumatic pressure, with unrestricted flow, and at room temperature.

	<u>Opening</u>	<u>Closing</u>
NW25	0.12 sec	0.18 sec
NW40	0.27 sec	0.53 sec
NW50	0.45 sec	1.13 sec

Under normal conditions, Pneumatic Square Body LoPro valves will greatly exceed *1 million* cycles before failure.

5.2.1.2 Manual Actuation

The opening and closing times are the limiting factors of the maximum cycle rate. Opening and closing times are dependent upon the operator and will vary dependent upon the application. Under normal conditions, Manual Square Body LoPro valves will greatly exceed 100,000 cycles before failure.

5.2.2 System Pressure Limits

Square Body LoPro Series valves are designed to function from UHV to greater than 2 Atm pressure (depending on size). Due to the elastomer seal on the bonnet, the lower pressure limit is determined by the vacuum system's tolerance for the gas load due to permeation through and leakage around that seal. All vacuum seals and welds in Square Body LoPro Series valves are He mass spectrometer tested with the maximum allowable leak rate being 1×10^{-9} std Atm cc/ sec. Although the Square Body LoPro valves may be a factor in the base pressure of a system, there is, in fact, no low system pressure limiting the valves' function.

High pressure, however, can cause failure in the pneumatic version. With the valve open, the opening force exerted on the nosepiece by excessive internal pressures will exceed the spring's closing force and the valve will fail to close completely. A similar pressure applied to the bottom port of a closed valve could force the valve to open or "blow by." These pressures are as follows:

NW25	43 psia (3.0 x 10 ⁵ Nt/m ² abs)
NW40	60 psia (4.1 x 10 ⁵ Nt/m ² abs)
NW50	38 psia (2.6 x 10 ⁵ Nt/m ² abs)

Higher pressures could cause bonnet seal extrusion, collapse of the bellows or rupture of the valve body.

5.2.3 Pneumatic Pressure Limits - Pneumatic Actuation Only

The dynamic seals used in the Square Body LoPro are rated for use at pressures significantly greater than those found on a typical compressed air system as are the other components of the cylinder. However, we strongly recommend not using pneumatic pressures in excess of 150 psig. If the valve is equipped with the optional solenoid pilot valve, pneumatic pressures in excess of 125 psig will result in pneumatic leakage and possible valve failure.

As described in section 4.1, sufficient pneumatic pressure must be applied to the piston to overcome the spring's closing force and open the valve. As the nosepiece moves away from the seat, the spring is compressed further requiring more force. A minimum pneumatic pressure of 40 psig is required for proper valve function.

5.2.4 Pneumatic Flow- Pneumatic Actuation Only

Insufficient pneumatic flow due to inadequate line diameter can result in temporary downstream decreases in pressure. The lines leading to the valve must be able to provide the volume of air at the pressure specified in section 5.2.3 for the valve to open in the time listed in section 5.2.1. Although the flow is dependent upon upstream restrictions, the cylinder volume required is as follows:

NW25	1.16 in ³ (19.0 cm ³)
NW40	2.21 in ³ (36.2 cm ³)
NW50	6.36 in ³ (104.2 cm ³)

5.2.5 Limit Switch Ratings- Pneumatic Actuation Only

The optional limit switch package uses miniature switches rated for 5 Amp at 250 V AC and 5 Amp at 30 V DC.

5.2.6 Solenoid Duty Cycle and Power Requirements

The solenoid coils supplied with valves equipped with pneumatic pilot valves are rated for continuous duty at their specified voltages and frequencies. Power requirement for the coil is 6 Watts in AC and 7 Watts in DC.

5.3 Dimensions

5.3.1 Dimensions – Manual Actuation

Figure 6 – Manual In-line valve dimensions

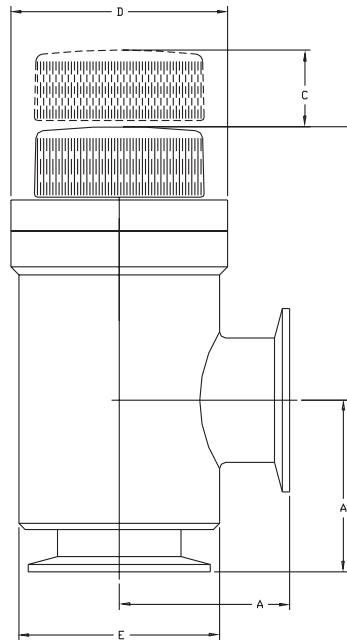

Manual In-line Square Body LoPro

Figure 6 dimensions:

	A	B	C	D	E
LPV1-25-AC-	2.02	3.34	0.60	2.27	2.00
LPV1-25-AK-	1.97	3.34	0.60	2.27	2.00
LPV1-25-AT-	1.88	3.34	0.60	2.27	2.00
LPV1-40-AC-	2.43	3.73	0.70	2.67	2.50
LPV1-40-AK-	2.56	3.73	0.70	2.67	2.50
LPV1-40-AT-	2.25	3.73	0.70	2.67	2.50
LPV1-50-AC-	3.19	4.51	1.20	3.51	3.25
LPV1-50-AK-	2.76	4.51	1.20	3.51	3.25
LPV1-50-AT-	3.00	4.51	1.20	3.51	3.25

All values are in inches.

Figure 7 – Manual Angle valve dimensions

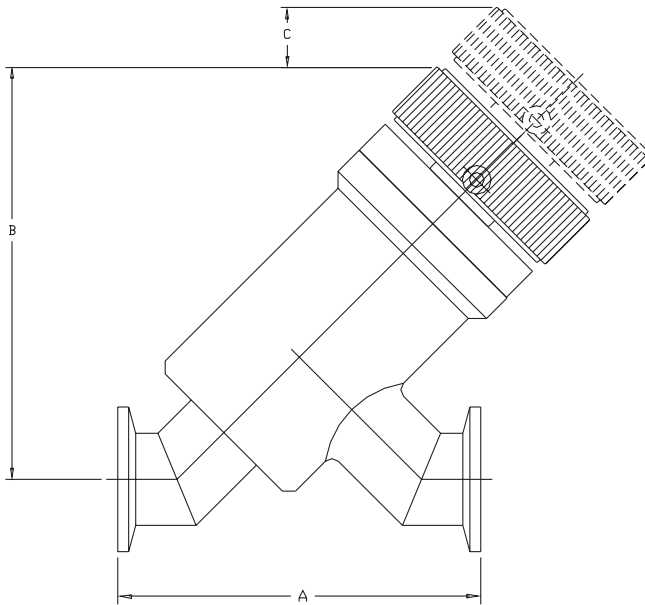

Manual Angle Square Body LoPro

Figure 7 dimensions:

	A	B	C
LPV1-25-IC-	4.62	4.50	0.42
LPV1-25-IK-	3.94	4.50	0.42
LPV1-25-IT-	4.35	4.50	0.42
LPV1-40-IC-	5.19	5.20	0.50
LPV1-40-IK-	5.12	5.20	0.50
LPV1-40-IT-	4.83	5.20	0.50
LPV1-50-IC-	7.59	6.20	0.85
LPV1-50-IK-	7.00	6.20	0.85
LPV1-50-IT-	7.20	6.20	0.85

5.3.2 Dimensions – Pneumatic Actuation

Figure 8 - Pneumatic In-line Square Body LoPro

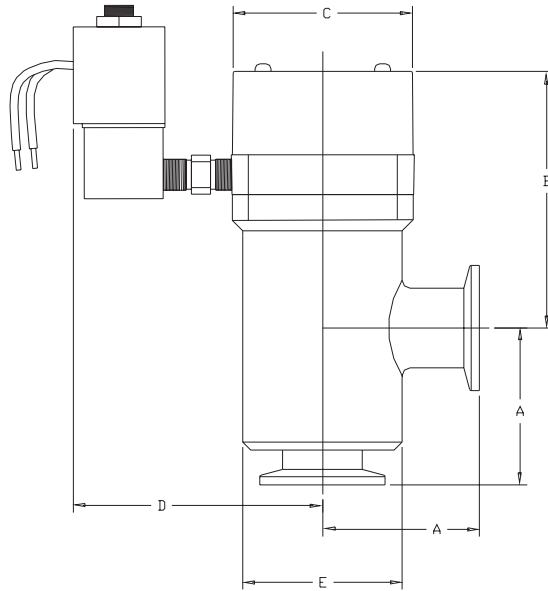

Pneumatic In-line Square Body LoPro

Figure 8 dimensions

	A	B	C	D	E
LPV1-25-AC-	2.02	3.62	2.24	3.13	2.00
LPV1-25-AK-	1.97	3.62	2.24	3.13	2.00
LPV1-25-AT-	1.88	3.62	2.24	3.13	2.00
LPV1-40-AC-	2.43	3.88	2.75	3.38	2.50
LPV1-40-AK-	2.56	3.88	2.75	3.38	2.50
LPV1-40-AT-	2.25	3.88	2.75	3.38	2.50
LPV1-50-AC-	3.19	5.04	3.49	3.75	3.25
LPV1-50-AK-	2.76	5.04	3.49	3.75	3.25
LPV1-50-AT-	3.00	5.04	3.49	3.75	3.25

All values are in inches.

Figure 9 - Pneumatic Angle Square Body LoPro

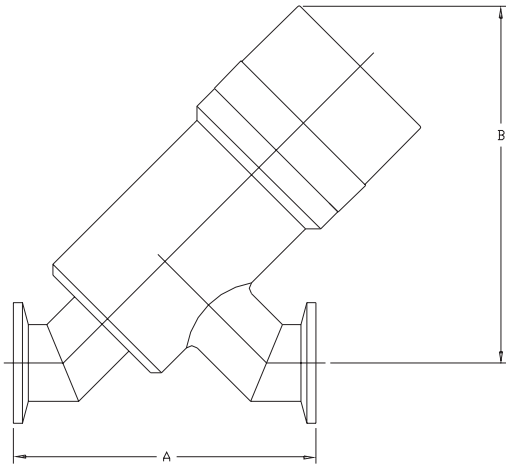

Pneumatic Angle Square Body LoPro

Figure 9 dimensions:

	A	B
LPV1-25-IC-	4.62	4.65
LPV1-25-IK-	3.94	4.65
LPV1-25-IT-	4.35	4.65
LPV1-40-IC-	5.19	5.34
LPV1-40-IK-	5.12	5.34
LPV1-40-IT-	4.83	5.34
LPV1-50-IC-	7.59	6.80
LPV1-50-IK-	7.00	6.80
LPV1-50-IT-	7.20	6.80

5.3.3 Weight

Measurements of weight for Square Body LoPro valves and their options are as follows:

NW25 Manual LoPro valve	1.6 lb
NW40 Manual LoPro valve	2.8 lb
NW50 Manual LoPro valve	4.8 lb
NW25 Pneumatic LoPro valve	1.6 lb
NW40 Pneumatic LoPro valve	3.0 lb
NW50 Pneumatic LoPro valve	5.4 lb
NW25 limit switches	0.16 lb (72.6g)
NW40 limit switches	0.20 lb (90.7g)
NW50 limit switches	0.27 lb (122g)
Solenoid pilot valve	0.46 lb (209g)

6. Installation Information

6.1 Pneumatic Supply– Pneumatic Actuation Only

Facility pneumatic supplies often contain contamination including rust, metal particles, oil, and water. A simple in-line filter in series with the supply for each valve or the supply for an entire system may remove particle contamination. Available from HPS®, part number 100001504, the Master Pneumatic - Detroit, Inc. model FC50-1 is a suitable filter for local filtration of typical pneumatic supplies.

The exhaust vents on the solenoid valves originally provided with HPS® valves are internally tapped to accept 10-32 UNF fittings to attach to a vent manifold if local external venting is not desired. If desired, a nonrestrictive exhaust muffler can be fitted to the valves to help reduce the vent noise.

The piston seal's sliding surface has been lubricated, making possible the use of "dry" pneumatic supplies without harm to the Square Body LoPro valve. However, the life of the solenoid pilot valve is considerably longer when the air supply contains trace quantities of moisture or oil.

6.2 Electrical Connections– Pneumatic Actuation Only

Electrical connections within the valve assembly must be made whenever the valve is equipped with limit switches and sometimes when using the optional solenoid pilot valve.

Two entries with grommets are provided in the limit switch cover (19 in Figure 3, p.7), one for a multi-conductor cable and the other for the solenoid pilot valve leads. Normally, the space inside the limit switch cover is used as a junction box for the solenoid and limit switch wires. However, care must be exercised to keep insulated wires from interfering with the movement of the cam extension (17) and the levers of the limit switches (16, 18). More important, exposed conductors must never make contact with any part of the limit switch assembly. Additionally, use of the stress relief clamps and ground lug provided is essential to safe electrical operation.

Care must be used when soldering leads to the terminals of the limit switches. A soldering iron with a thermostatically controlled tip should be used. The soldering iron should not be in contact with the switch terminals for longer than 10 seconds.

6.3 Clean Installation

Valves are shipped with plastic covers over the ports. These covers should be left in place until the valve is installed. All Square Body LoPro valves are cleaned at the factory for direct installation and high vacuum service. Normal clean assembly techniques should be practiced, as the presence of airborne particles on the nosepiece seal (9 in [Figure 2](#)), the seat (8), or on the sealing surfaces of the port flanges may result in leakage.

6.4 Flange Care

Care should be taken not to damage the flanges. To help protect the flanges, the plastic caps supplied with the valve should remain in place until installation and be replaced when removed from a system. A small scratch on the flange seal surface of an elastomer sealed flange could prevent a leak tight seal. Similarly, on valves with CF (metal seal) flanges, scratches or dents in the knife edge may prevent the flange from sealing. Since the flanges are integrated with the body, a defective flange could result in replacement of the body.

When installing the valve, adequate clearance should be allowed between adjacent components so there is no sliding of seal surfaces against one another. Flanges that have been assembled for some time may have a tendency to stick together. Care should be exercised when prying flanges apart as to avoid damaging their sealing surfaces.

7. SERVICE

7.1 Removal from System

Prior to removing the entire valve or a valve's actuator assembly from a vacuum system, it is necessary to bring the system up to atmospheric pressure. Purge and vent hazardous gasses appropriately.

7.1.1 Pneumatic Version

Detach the pneumatic supply. To avoid injury, be sure the pneumatic line is depressurized prior to disconnection from the valve.

If the valve is equipped with the solenoid operated pilot valve it will be necessary to disconnect these leads. To avoid electrocution, be sure the power to the pilot valve is off prior to disconnection. Refer to section 7.5 for details on solenoid pilot valve repair.

If the valve is equipped with limit switches, the limit switch assembly may be removed from the valve without disconnecting the leads. For details on this procedure, refer to section 7.4.

Loosen and remove the clamps or bolts on the port flanges. If possible, pull one of the flanges mating to a port flange directly away from the valve to allow removal of the valve without scraping sealing surfaces. Replace the protective plastic caps on the port flanges or cover the ports with aluminum foil.

Avoid touching the interior surfaces of the valve. Moisture, skin oils, and dirt may contaminate the interior of the valve, affecting its performance upon reinstallation, and/or, more importantly, films deposited on the interior surfaces of the valve may be toxic.

7.1.2 Manual Version

Loosen and remove the clamps or bolts on the port flanges. If possible, pull one of the flanges mating to a port flange directly away from the valve to allow removal of the valve without scraping sealing surfaces. Replace the protective plastic caps on the port flanges or cover the ports with aluminum foil.

Avoid touching the interior surfaces of the valve. Moisture, skin oils, and dirt may contaminate the interior of the valve, affecting its performance upon reinstallation, and/or, more importantly, films deposited on the interior surfaces of the valve may be toxic.

7.2 Actuator Assembly – Pneumatic Version

7.2.1 Actuator Assembly Removal and Disassembly

The following procedure does not require removal of the valve body from the system. However, several aspects of the procedure are more easily performed if the entire valve is removed. Read section 7.1.1 prior to removing the entire valve or a valve's actuator assembly from a vacuum system.

The actuator assembly is attached to the bonnet of the valve by four bolts. To remove the actuator assembly, simply loosen and remove these four bolts. After the bolts are removed, carefully pull the actuator assembly out of the valve body. The bellows is fabricated of .006" thick 321 stainless steel. While withdrawing the actuator assembly, exercise care to avoid damaging the bellows. If the bonnet o-ring has adhered to the sealing surface in the body carefully remove it by hand. If a tool is required for this task, it should be made of a material softer than stainless steel to avoid scratching the sealing surface.

The actuator assembly contains a powerful spring under some compression at all times. A special fixture is required for further, safe disassembly of the actuator. Replacement of malfunctioning actuators with new assemblies is recommended (see parts list in section 7.6 for details).

7.2.2 O-Ring Replacement

The bonnet o-rings may easily be removed without a special fixture. With a little stretch, the bonnet o-ring clears the bellows and drops off of the actuator assembly.

Removal of the nosepiece o-ring usually requires a thin tool to pry it out of its trapezoidal groove. Exercise care to avoid damaging the sealing surface at the bottom of the groove. Start prying at the vent hole and carefully move around far enough to allow grasping the seal with the fingers. Then pull the seal from the remainder of the groove.

Be sure that no dust or other contamination is in the groove or on the o-ring. To install the o-ring, nest the o-ring on the opening of the groove. With the thumbs at points 180° apart, firmly press the o-ring into the groove. Move 90° and press again. Move 45° and press again. Alternately press the o-ring into the groove until it is completely in the groove. Hand installation will likely leave humps on the installed o-ring. As long as the o-ring has not twisted during assembly, this will disappear after a small number of cycles, after which the valve should function properly.

7.2.3 Actuator Assembly Installation

Insert the actuator assembly into the valve body. As with removal, take care to avoid damaging the bellows. Be sure that the bonnet o-ring is in place. The bellows flange is appropriately tapered to aid in retaining the o-ring in the proper position during assembly.

Before bolting the actuator to the valve body, make sure the pneumatic port is located in the desired orientation. Insert the four bolts and tighten the actuator to the valve body. The actuator assembly is completely installed when the bottom of the actuator is flush to the top of the valve body and the four attaching bolts are tightened to 45-50 in. lb. (» 5.0 Nm).

Reconnect the pneumatic supply and electrical connections (if applicable). Refer to section 7.4 for details on limit switch assembly.

It is highly recommended to check the assembly for leaks using a high quality Helium mass spectrometer leak detector. The vent slot in-between the actuator cap and the bonnet flange is used for leak detection. With the interior of the valve evacuated and attached to the He mass spectrometer, insert the tracer gas probe into this slot. If a leak is detected, either the bellows or the bonnet seal is faulty. The nosepiece seal and port flange seals may be tested through a variety of methods and will not be detailed here.

7.3 Actuator Assembly – Manual Version

7.3.1 Actuator Assembly Removal and Disassembly

The following procedure does not require removal of the valve body from the system. However, several aspects of the procedure are more easily performed if the entire valve is removed. Read section 7.1.2 prior to removing the entire valve or a valve's actuator assembly from a vacuum system.

The actuator assembly is attached to the bonnet of the valve by four bolts. To remove the actuator assembly, simply loosen and remove these four bolts. After the bolts are removed, pull the actuator assembly out of the valve body. The bellows is fabricated of .006" thick 321 stainless steel. While withdrawing the actuator assembly, exercise care to avoid damaging the bellows. If the bonnet o-ring has adhered to the sealing surface in the body carefully remove it by hand. If a tool is required for this task, it should be made of a material softer than stainless steel to avoid scratching the sealing surface.

Replacement of malfunctioning actuators with new assemblies is recommended (see parts list section 7.6 for details).

7.3.2 O-Ring Replacement

The bonnet o-rings may easily be removed without special fixture. With a little stretch, the bonnet o-ring clears the bellows and drops off of the actuator assembly.

Removal of the nosepiece o-ring usually requires a thin tool to pry it out of its trapezoidal groove. Exercise care to avoid damaging the sealing surface at the bottom of the groove. Start prying at the vent hole and carefully move around far enough to allow grasping the seal with the fingers. Then pull the seal from the remainder of the groove.

Be sure that no dust or other contamination is in the groove or on the o-ring. To install the o-ring, nest the o-ring on the opening of the groove. With the thumbs at points 180° apart, firmly press the o-ring into the groove. Move 90° and press again. Move 45° and press again. Alternately press the o-ring into the groove until it is completely in the groove. Hand installation will likely leave humps on the installed o-ring. As long as the o-ring has not twisted during assembly, this will disappear after a small number of cycles, after which the valve should function properly.

7.3.3 Actuator Assembly Installation

Before installing the actuator assembly, turn the manual knob so that the assembly is not in the bottomed out position. Insert the actuator assembly into the valve body. As with removal, take care to avoid damaging the bellows. Be sure that the bonnet o-ring is in place. The bellows flange is appropriately tapered to aid in retaining the o-ring in the proper position during assembly. Insert the four bolts and tighten the actuator to the valve body.

The actuator assembly is completely installed when the bottom of the actuator is flush to the top of the valve body and the four attaching bolts are tight. [Torque on bolts » 45-50 in. Lb. (5.0 Nm)]

It is highly recommended to check the assembly for leaks using a high quality Helium mass spectrometer leak detector. The vent slot inbetween the acuator cap and the bonnet flange is used for leak detection. With the interior of the valve evacuated and attached to the He mass spectrometer, insert the tracer gas probe into this slot. The bellows and bonnet seal are accessed for leak detection through this slot. The nosepiece seal and port flange seals may be tested through a variety of methods and will not be detailed here.

7.4 Limit Switches – Pneumatic Actuation Only

7.4.1 Limit Switch Removal

Be sure to disconnect all power prior to working on or adjusting the limit switches.

This first step applies to NW25 LoPro valves only; for larger valves, proceed to the next paragraph. Loosen and remove the two 6-32 pan head screws with star washers on the top of the limit switch housing. Slide the housing off of the assembly. Sometimes, the wires will hold the grommets in position as the housing is removed. This is not only acceptable, but can aid in assembly.

Loosen and remove the four 2-56 pan head screws on the top of the actuator assembly. (On the NW50 LoPro valves, there are six 2-56 pan head screws.) Withdraw the limit switch assembly directly away from the actuator assembly, keeping the central axis of the assembly concentric with that of the remainder of the valve until it is clear.

7.4.2 Limit Switch Installation

Carefully insert the cam extension into the hole in the center of the bottom of the limit switch assembly, keeping the axis of the limit switch assembly concentric with that of the cam extension.

Align the four holes (six in the NW50 LoPro valves) in the top of the cylinder with the four in the bottom of the limit switch assembly. Insert and tighten the pan head cap screws.

If the limit switch assembly was previously removed from *the valve it is being installed upon*, and the limit switches functioned properly before disassembly, readjustment is probably not necessary. Otherwise, see section 7.4.4 for details on limit switch adjustment.

On the NW25 LoPro valves, install the limit switch housing. Insert and tighten the two 6-32 pan head screws with star washers in the top of the housing.

7.4.3 LS Retrofit

With the valve in its closed position, loosen and remove the four 2-56 pan head screws holding the cover to the top of the cylinder. (On the NW50 LoPro there are six 2-56 pan head screws). Remove the Piston covers but **Do not remove the actuator assembly from the valve body.**

Using a 1/8 Allen wrench (5/32 for the NW50 LoPro valves), loosen and remove the flat head cap screw in the center of the piston. Insert the threads of the cam extension into the hole in the center of the piston. Tighten the threads using a 9/16 deep socket or open end wrench. Install

8) Teflon is a registered trademark of E.I. DuPont de Nemours Co.

the limit switch assembly as described in section 7.4.2, make electrical connections as discussed in section 6.2, and adjust the switches as detailed in section 7.4.4

7.4.4 Limit Switch Adjustment

An ohmmeter and pneumatic supply are required for limit switch adjustment. Connect the ohmmeter to the NC (normally closed) and C (common) terminals of the closed position limit switch. With the valve in its closed position, open circuit resistance should be indicated. Cycle the valve to its open position. Closed circuit resistance should be indicated (less than 0.5 ohm). Run the valve through several cycles to be sure that the switch is actuating properly and sufficiently near full closure.

If the switch does not actuate, actuates too early, or is always actuated, the switch needs adjustment. Loosen the lower 2-56 screw holding the switch just enough to allow movement of the switch about the upper 2-56 screw. Move the switch to correct the problem and tighten the lower 2-56 screw. Test the operation of the switch through several cycles to ensure proper function. Repeat these steps until it functions properly.

Connect the ohmmeter to the NC and C terminals of the open position limit switch. With the valve in its closed position, closed circuit resistance should be indicated. Cycle the valve to its open position. Open circuit resistance should be indicated. Run the valve through several cycles to be sure that the switch is actuating properly and when the valve is fully opened.

If the switch does not actuate, actuates too early, or is always actuated, the switch needs adjustment. Loosen the upper 2-56 screw holding the switch just enough to allow movement of the switch about the lower 2-56 screw. Move the switch to correct the problem and tighten the upper 2-56 screw. Test the operation of the switch through several cycles to ensure proper function. Repeat these steps until it functions properly.

7.5 Solenoid Pilot Valve Service – Pneumatic Actuation Only

In normal use, solenoid pilot valves should last millions of cycles, although this number is reduced by about a factor of ten when a dry pneumatic supply is used.

The solenoid valve is connected to the actuator cylinder by a 1/8" NPT nipple and the threads are sealed with a jointing compound or Teflon[®] tape. If Teflon tape is used, excess tape overlapping the end of the nipple in the assembly can be sheared off, resulting in blockage of pneumatic flow and possible valve failure.

The coil is the only replaceable component of the solenoid pilot valve. After removing the jam nut, the coil slips off of the housing of the valve. Install the new coil and tighten the jam nut. Orientation of the coil wires has no affect on the function of the valve.

7.6 Replacement Parts List

NW25 LoPro valves

Manual actuation internals..	100010128
Actuator with no seals.....	100010104
Buna-N seal kit.....	100002215
Kalrez ^(R) seal kit.....	100002218
Silicone seal kit.....	100002221
Viton ^(R) seal kit.....	100002224
Chemraz seal kit.....	100009145
limit switch kit	100002227

NW40 LoPro valves

Manual actuation internals...100010129
Actuator with no seals.....100010103
Buna-N seal kit.....100002216
Kalrez ^(R) seal kit.....100002219
Silicone seal kit.....100002222
Viton ^(R) seal kit.....100002225
Chemraz seal kit.....100009146
limit switch kit.....100002228

NW50 LoPro valves

Manual actuation internals..	100010130
Actuator with no seals.....	100010102
Buna-N seal kit.....	100002217
Kalrez ^(R) seal kit.....	100002220
Silicone seal kit.....	100002223
Viton ^(R) seal kit.....	100002226
Chemraz seal kit.....	100009147
limit switch kit.....	100010102

Replacement Solenoid Valves

24 VAC 50/60 Hz.....	100008164
12 VDC	100008539
24 VDC	100008163
120VAC 50/60 Hz.....	100008165
208VAC 50/60 Hz.....	100008166
220VAC 50/60 Hz.....	100008167

8. Trouble Shooting



The following sections outline diagnosis of possible problems encountered when using HPS® Square Body LoPro Series valves and detail possible causes and their remedies.

8.1 Problems and Diagnosis Pneumatic Actuation

8.1.1 Won't close completely

High magnitude leakage across the nosepiece seal when the valve is supposedly closed is evidence for failure to close completely. The absence of a signal from the closed limit switch (if so equipped) would be further evidence. In valves that have visual access to one or both of the ports, a gap between the nosepiece and the seat might be observed.

If the gap between the nosepiece and seat is large (greater than .1") or there seems to be loose components rattling about inside the bellows, see section 8.3.1 on spring failure. Otherwise refer to section 8.3.12 covering improper assembly.

8.1.2 Won't open completely

Failure to open completely can be detected directly by the absence of a signal from the open limit switch (if so equipped). It can also be observed through the hole in the center of the piston cover. Lastly, a significant decrease in the valve's conductance may be an indication.

First, see section 8.3.15 on inadequate air pressure. If pneumatic pressure is within recommended limits and compressed air is leaking and possibly heard through the hole in the piston cover but is not coming out of the vent in the actuator cylinder, see section 8.3.8 on piston seal leakage. If the air is spraying through the actuator vent when the valve is static, see section 8.3.9 on stem seal leakage. Last, if there are no other symptoms other than incomplete opening, see section 8.3.13 on loose piston hold down screws.

8.1.3 Opens slowly or in jumps

An abnormally long delay between signals from the two limit switches is direct evidence of slow opening. It can also be observed through the hole in the center of the piston cover, comparing the actuation time to that in the

specifications. Movement in jumps, called slip sticking, can be observed through the same hole. The vibration caused by slip stick jumps can often be felt manually and sometimes heard.

First, see section 8.3.15 on inadequate air pressure. If pneumatic pressure is within recommended limits, refer to section 8.3.16 covering inadequate airflow. Lastly, see section 8.3.14 on inadequate or exhausted lubrication.

8.1.4 Won't open at all

Continuation of the signal from the closed limit switch (if so equipped) and zero conductance through the valve are both good indications that the valve has not opened. Visual observation of the piston's failure to move can be made through the hole in the center of the piston cover.

First, see section 8.3.15 on inadequate air pressure. If pneumatic pressure is within recommended limits, refer to section 8.3.19 on stem weld failure. Last, if air is blasting from around the piston hold down screw when the valve is trying to open, see section 8.3.13 on loose piston hold down screws.

8.1.5 Squeaks when opening and/or closing

LoPro valves normally make a barely audible squeak when they open. This is caused by the spring making contact with the bushing that prevents the spring from buckling and damaging critical components.

A loud grinding or squeaking may be indicative of a problem. If there seems to be loose components rattling about inside the valve, see section 8.3.1 on spring failure. Also check section 8.3.14 on inadequate lubrication.

8.1.6 Leaks across closed nosepiece seal

Detection of leakage across the nosepiece seal when the valve is closed can be symptomatic of several problems. See section 8.1.1 if the valve also isn't closing completely.

Refer to section 8.3.11 on nosepiece seal omission. If the o-ring is present, particles, contamination, and corrosion may be the problem, see section 8.3.4. If the valve continues to leak after the seat and sealing area have been cleaned, see section 8.3.7 on bonnet seal failure.

8.1.7 Leaks from atmosphere when closed

If leakage is detected from atmosphere when the valve is closed, see section 8.3.12 on improper assembly. If the assembly is correct, refer to section 8.3.7 on bonnet seal failure. Lastly, see section 8.3.2 on body damage.

8.1.8 Leaks from atmosphere when open

If leakage is detected from atmosphere when the valve is open, see section 8.3.5 on bellows failure.

8.1.9 Leaks from atmosphere at all times

If leakage is detected from atmosphere at all times, see section 8.3.5 on bellows failure. If the bellows has not failed, refer to section 8.3.7 on bonnet seal failure. Also see sections 8.3.10 on bonnet seal omission, 8.3.12 on improper assembly, 8.3.2 on body damage, and 8.3.3 on port flange damage.

8.1.10 Air leaks from around piston when open

If compressed air can be heard or possibly felt escaping from the hole in the center of the piston cover, but is not emanating from the vent in the actuator cylinder, see section 8.3.8 on piston seal failure.

8.1.11 Air leaks from vent hole while opening

The slot in between the actuator cylinder and the bellows flange vents the interior of the bellows as its volume changes during the stroke. This venting is normal and necessary *while the valve is dynamic (opening or closing)*.

8.1.12 Air leaks from vent hole when open

If compressed air can be felt escaping from the vent slot in actuator cylinder when the valve is open, see section 8.3.9 on stem seal failure.

8.1.13 Limit switches not sending signals

Be sure that the valve is opening and/or closing completely, see sections 8.1.1 and 8.1.2. If the valve has traveled its full stroke, see section 8.3.17 about limit switch failure.

8.1.14 Solenoid valve buzzes or doesn't work

If air is not passing through the solenoid pilot valve or is buzzing during activation, see section 8.3.18 on solenoid valve failure.

8.2 Problems and Diagnosis Manual Actuation

8.2.1 Won't close completely

High magnitude leakage across the nosepiece seal when the valve is supposedly closed is evidence for failure to close completely. In valves that have visual access to one or both of the ports, a gap between the nosepiece and the seat might be observed.

If the gap between the nosepiece and seat is large (greater than .1") or there seems to be loose components rattling about inside the bellows, see section 8.3.12 covering improper assembly. If the gap between the nosepiece and seat is small (less than .1") see section 8.2.4.

8.2.2 Won't open completely

Failure to open completely can be detected directly by the manual screw not reaching full extension. A significant decrease in the valve's conductance may also be an indication. See section 8.3.12 covering improper assembly.

8.2.3 Difficult to open/close or Squeaks

Square Body LoPro valves normally make a barely audible squeak when they open. An Increase in squeaking and opening difficulty usually indicates inadequate lubrication on the manual screw.

First, see section 8.3.14 on inadequate lubrication. If the manual screw is properly lubricated, see section 8.3.12 on improper assembly.

8.2.4 Leaks across closed nosepiece seal

Detection of leakage across the nosepiece seal when the valve is closed can be symptomatic of several problems. See section 8.2.1 if the valve isn't closing completely.

Refer to section 8.3.11 on nosepiece seal omission. If the o-ring is present, particles, contamination, and corrosion may be the problem, see section 8.3.4. If the valve continues to leak after the seat and sealing area have been cleaned, see section 8.3.7 on bonnet seal failure.

8.2.5 Leaks from atmosphere when closed

If leakage is detected from atmosphere when the valve is closed, see section 8.3.12 on improper assembly. If the assembly is correct, refer to section 8.3.7 on bonnet seal failure. Lastly, see section 8.3.2 on body damage.

8.2.6 Leaks from atmosphere when open

If leakage is detected from atmosphere when the valve is open, see section 8.3.5 on bellows failure.

8.2.7 Leaks from atmosphere at all times

If leakage is detected from atmosphere at all times, see section 8.3.5 on bellows failure. If the bellows has not failed, refer to section 8.3.7 on bonnet seal failure. Also see sections 8.3.10 on bonnet seal omission, 8.3.12 on improper assembly, 8.3.2 on body damage, and 8.3.3 on port flange damage.

8.3 Causes and Remedies

8.3.1 Spring failure – Pneumatic Actuation Only

The normal Square Body LoPro valve spring has a life greater than 1×10^6 cycles. In the rare event of a failure, the best remedy is to return the valve to the manufacturer for repair due to the special fixture required for complete disassembly of the actuator assembly.

8.3.2 Body damage

All Square Body LoPro valves are thoroughly tested after assembly. Body damage serious enough to result in detectable leakage could be caused by mishandling or abuse in shipping or in the installation. A damaged body is not easily repaired, usually costing more for the repair than a replacement. Often, with serious body damage, the actuator assembly has also been damaged, making replacement of the entire valve the best solution.

8.3.3 Port flange damage

Flanges are easily damaged after the protectors have been removed. *Avoid contact between the flanges and any surface.* Small sealing surface defects can sometimes be corrected with application of a high quality vacuum grease, such as Apiezon⁹, to the seal. Larger defects might be repaired by rubbing out the scratch or dent with a light abrasive, such as Scotch Brite¹⁰. Working of the abrasive should always be parallel to the direction of the seal. For example, a scratch on a surface sealed by a circular o-ring should, likewise, be worked with the abrasive in circular fashion. Heavier damage would require replacement of the body.

9) Apiezon is the trademark of GEC Alsthom, Ltd.

10) Scotch Brite is a registered trademark of 3M.

8.3.4 Particulates, condensation, and corrosion

In normal use, airborne particulates, process condensation, and/or corrosion, may effect seal integrity. Particulates might be moved by simple turbulent gas flow. However, condensed or sublimated films nearly always require further cleaning. Additionally, corroded sealing surfaces may be irreparable. Replacing the component being the only remedy.

8.3.5 Bellows failure

Although the mean time between failures for the Square Body LoPro bellows is greater than 10^6 cycles, nearly all valve failures are the result of bellows failures. Stress cracks in the convolution crowns are first detected when the valve is open and the bellows is in compression. At this time, the outside of the bellows material is in tension, opening minute cracks wider than when the bellows is relaxed or in extended. Eventually, the crack(s) will propagate around the entire convolution and the bellows will separate. Long before, the atmospheric leak will be detected constantly. The only remedy is to replace the actuator assembly.

8.3.6 Nosepiece seal failure

Elastomer seals that have remained in a compressed condition for long periods of time may not return to their original circular cross section when released. Such seals may stick to the mating sealing surface as they are pulled apart, leaving bits of the seal behind. Old elastomers tend to lose some of their elasticity and may crack. Various process gasses and/or high temperatures accelerate all of these effects. Reference section 7.2.2 on o-ring replacement.

8.3.7 Bonnet seal failure

Elastomer seals that have remained in a compressed condition for long periods of time may not return to their original circular cross section when released. Such seals may stick to the mating sealing surface as they are pulled apart, leaving bits of the seal behind. Old elastomers tend to lose some of their elasticity and may crack. Various process gasses and/or high temperatures accelerate all of these effects. Reference section 7.2.2 on o-ring replacement.

8.3.8 Piston seal failure – Pneumatic Actuation Only

The seals used on the pneumatic pistons are normally good for much more than 10^6 cycles. However, an occasional defect in the material, in the seal's installation, or inadequate lubrication could cause a bit of the edge of this seal to break off, resulting in a pneumatic leak. Due to the special fixture required to fully disassembly the actuator assembly, factory repair or replacement is recommended.

8.3.9 Stem seal failure – Pneumatic Actuation Only

The seals used on pneumatic stems are normally good for much more than 10⁶ cycles. However, an occasional defect in the material, in the seal's installation, or inadequate lubrication could cause a bit of the edge of this seal to break off, resulting in a pneumatic leak. Due to the special fixture required to fully disassembly the actuator assembly, factory repair or replacement is recommended.

8.3.10 Bonnet seal omission

After service, during assembly, omission of the bonnet seal will cause the valve to leak from atmosphere at all times. Remove the actuator assembly and install the seal.

8.3.11 Nosepiece seal omission

After service, during assembly, omission of the nosepiece seal will cause the valve to leak from one port to the other when the valve is closed. Remove the actuator assembly and install the seal.

8.3.12 Improper assembly

After service, the actuator must be inserted to its stop, reference section 7.2.3 on pneumatic actuator assembly installation or 7.3.3 on manual actuator assembly installation. Failure to do so could result in the valve not closing completely, or leaking in its closed position.

8.3.13 Loose piston hold down screw – Pneumatic Actuation Only

The piston hold down screw, a flat head socket drive cap screw, can work itself loose if not tightened adequately during assembly or if improperly assembled. Remove the piston cover and, *with the valve closed*, remove the piston hold down screw. **Do not remove the actuator assembly from the body during this process**, (If the valve is equipped with the optional limit switch package, follow the directions for its removal section 7.4.1.) Apply a light film of a good quality thread locking compound, such as Tight¹¹, to the threads of the piston hold down screw and tighten.

8.3.14 Inadequate lubrication

Pneumatic Actuation

Normally the Square Body LoPro's dynamic components require very little lubrication. However, dry environments, high temperatures, and corrosive atmospheres may exhaust most of the lubricating properties of the greases used. The least effect of this is to increase the friction on the piston and stem, but could result to damaged components and failure. Remove the

11) Tight is a trademark of Fel Pro, Inc.

piston cover and apply a film of a high quality lubricant for elastomer/metal interfaces, such as Fomblin VAC 3¹², to the inside of the cylinder. Cycle the valve several times and reapply the grease.

Manual Actuation

Normally the Square Body LoPro's dynamic components require very little lubrication. However, dry environments, high temperatures, and corrosive atmospheres may exhaust most of the lubricating properties of the greases used. The least effect of this is to increase the friction on the manual screw, but could result to damaged components and failure. Actuate the manual knob to the fully open position and apply a film of a high quality lubricant for metal/metal interfaces, such as Dow Corning 1122 grease, to the base of the manual screw. Cycle the valve several times to distribute grease and reapply if necessary.

8.3.15 Inadequate air pressure – Pneumatic Actuation Only

The specifications define minimum operating pressures for Square Body LoPro valves. If the pneumatic supply pressure is too low, it must be increased, (see section 5.2.2 on system pressure limits).

8.3.16 Inadequate air flow – Pneumatic Actuation Only

More difficult to detect than inadequate pressure, low flow may cause slow actuation of the valve. If the pneumatic line is equipped with a gauge, watch the pressure as the valve is actuated. If it decreases significantly with each slow actuation then pneumatic flow is inadequate. Check for kinks or other blockages in the line. If the low flow is due to demand greater than capacity, installation of additional capacity must be considered, (see section 5.2.4 on pneumatic flow).

8.3.17 Limit switch failure – Pneumatic Actuation Only

If a limit switch cannot be activated manually when the cam is at the opposite switch, replace the limit switches. Check to make sure the valve is indeed opening and/or closing completely. If these check out, refer to section 7.4.4 on limit switch adjustment.

8.3.18 Solenoid valve failure – Pneumatic Actuation Only

During long or quickly repeated duty cycles, the solenoid valve's coil will normally exceed 70° C. Voltages lower than specified can increase that temperature and accelerate the failure of the coil. Incorrect voltages can cause immediate failure and subsequent replacement of the solenoid valve's coil.

12) Fomblin is a registered trademark of Montefluos, Ausimont Group, Montedison Specialty Chemicals.

Dirt or other contamination from the pneumatic supply can inhibit the movement of the plunger and cause the valve to leak. Sometimes this problem manifests itself in an oscillation of the plunger, resulting in readily audible buzz. The best remedy is to replace the entire solenoid valve. Installation of a filter in the pneumatic line upstream from the valve can prolong the life of the valve.

8.3.19 Stem Weld Failure

A disproportionately high percentage of early LoPro valves experienced a failure in the weld joining the nosepiece to the stem. This process problem was corrected January 10, 1992. There have been no reports of this failure on any valve built after that date. Such a failure may only be repaired at the factory due to the special fixture required for complete disassembly of the actuator assembly.

9. RETURN TO FACTORY FOR REPAIR OR SERVICE



Before shipping a Square Body LoPro valve to the factory, please observe the following procedure:

9.1 Call the factory

The HPS® Customer Service Department or any MKS Service Center will prepare a Returned Material Report (RMR). Consequently, when the item is received, disposition will occur in a timely manner.

The customer service person will need information on the following:

- > What is the problem?
- > What are the symptoms, and how were they observed?
- > What is the application?
- > Is it an urgent repair?
- > What is the valve's serial number?
- > What is the user's name and where can he be reached?
- > Was the valve used with any dangerous, toxic, or radioactive

materials? HPS® is not equipped to handle such items. Items having **ANY** unidentified coatings or films will be treated as hazardous waste and appropriately disposed at the sender's expense. Additionally, the shipment of hazardous materials through the mail or on any private carrier not specifically licensed for the handling of such materials is a federal offense.

With this information, the customer service person will issue an RMR number specific to this return.

9.2 Prepare for shipment

Be sure the valve is clean and free of any hazardous materials. Cap the ports to prevent entry of foreign material and to protect the sealing surfaces. Place the valve in a sealed plastic bag, and pack securely in a sturdy shipping container. Poor packing can result in damage to the valve. Insert a packing slip or letter referencing the RMR number issued by the customer service person.

10. Product Warranty

Extent of the Warranty

MKS Instruments, Inc. (MKS), warrants the HPS® PDR 9000 and its accessories to be free from defects in materials and workmanship for one (1) year from the date of shipment by HPS® or authorized representative to the original purchaser (PURCHASER). Any product or parts of the product repaired or replaced by HPS® under this warranty are warranted only for the remaining unexpired part of its one (1) year original warranty period. After expiration of the applicable warranty period, the PURCHASER shall be charged HPS® current prices for parts and labor, plus any transportation for any repairs or replacement.

ALL EXPRESS AND IMPLIED WARRANTIES, INCLUDING THE IMPLIED WARRANTIES OF MERCHANTABILITY AND FITNESS FOR A PARTICULAR PURPOSE, ARE LIMITED TO THE WARRANTY PERIOD. NO WARRANTIES, EXPRESS OR IMPLIED, WILL APPLY AFTER THIS PERIOD.

Warranty Service

The obligations of HPS® under this warranty shall be at its option: (1) to repair, replace, or adjust the product so that it meets applicable product specifications published by HPS® or (2) to refund the purchase price.

What Is Not Covered

The product is subject to above terms only if located in the country of the seller from whom the product was purchased. The above warranties do not apply to:

- I. Damages or malfunctions due to failure to provide reasonable and necessary maintenance in accordance with HPS® operating instructions.
- II. Damages or malfunctions due to chemical or electrolytic influences or use of the product in working environments outside the specification.
- III. Fuses and all expendable items which by their nature or limited lifetime may not function for a year. If such items fail to give reasonable service for a reasonable period of time within the warranty period of the product; they will, at the option of HPS®, be repaired or replaced.
- IV. Defects or damages caused by modifications and repairs effected by the original PURCHASER or third parties not authorized in the manual.

Condition of Returned Products

HPS® will not accept for repair, replacement, or credit any product which is asserted to be defective by the PURCHASER, or any product for which paid or unpaid service is desired, if the product is contaminated with potentially corrosive, reactive, harmful, or radioactive materials, gases, or chemicals.

When products are used with toxic chemicals, or in an atmosphere that is dangerous to the health of humans, or is environmentally unsafe, it is the responsibility of the PURCHASER to have the product cleaned by an independent agency skilled and approved in the handling and cleaning of contaminated materials before the product will be accepted by HPS® for repair and/or replacement.

In the course of implementing this policy, HPS® Customer Service Personnel may inquire of the PURCHASER whether the product has been contaminated with or exposed to potentially corrosive, reactive, harmful, or radioactive materials, gases, or chemicals when the PURCHASER requests a return authorization. Notwithstanding such inquiries, it is the responsibility of the PURCHASER to ensure that no products are returned to HPS® which have been contaminated in the aforementioned manner.

Other Rights and Remedies

- I. These remedies are exclusive. HPS® SHALL NOT BE LIABLE FOR CONSEQUENTIAL DAMAGES, FOR ANTICIPATED OR LOST PROFITS, INCIDENTAL DAMAGES OR LOSS OF TIME, OR OTHER LOSSES INCURRED BY THE PURCHASER OR BY ANY THIRD PARTY IN CONNECTION WITH THE PRODUCT COVERED BY THIS WARRANTY, OR OTHERWISE. Some states do not allow exclusion or limitation of incidental or consequential damage or do not allow the limitation on how long an implied warranty lasts. If such laws apply, the limitations or exclusions expressed herein may not apply to PURCHASER.
- II. Unless otherwise explicitly agreed in writing, it is understood that these are the only written warranties given by HPS®. Any statements made by any persons, including representatives of HPS®, which are inconsistent or in conflict with the terms of the warranty shall not be binding on HPS® unless reduced to writing and approved by an authorized officer of HPS®.
- III. This warranty gives PURCHASER specific legal rights, and PURCHASER may also have other rights which vary from state to state.
- IV. For HPS® products sold outside of the U.S., contact your MKS™ representative for warranty information and service.

Warranty Performance

To obtain warranty satisfaction, contact the following: MKS™ Instruments HPS® Products, Inc., 5330 Sterling Drive, Boulder, CO 80301, USA, at phone number (303) 449-9861. You may be required to present proof of original purchase.

10.1 WHAT IS NOT COVERED

The above warranties do not apply to the following:

- > Damages or malfunctions due to failure to provide reasonable and necessary maintenance in accordance with HPS® operating instructions.
- > Damages or malfunctions due to chemical or electrolytic influences, or use of the product in working environments outside the specifications.
- > Seals, bellows, and all expendable items, which by their nature or limited lifetimes may not function for one year. (If such items fail to give reasonable service for a reasonable period of time within the warranty period of the product, they will, at the option of HPS®, be repaired or replaced.)
- > Defects, damages, or malfunctions caused by modifications and/or repairs effected by the Purchaser or unauthorized third parties.

10.2 OTHER RIGHTS AND REMEDIES

HPS® SHALL NOT BE LIABLE FOR CONSEQUENTIAL DAMAGES, FOR ANTICIPATED OR LOST PROFITS, INCIDENTAL DAMAGES, OR LOSS OF TIME OR OTHER LOSSES INCURRED BY THE PURCHASER OR BY ANY THIRD PARTY IN CONNECTION WITH THE PRODUCT COVERED BY THIS WARRANTY, OR OTHERWISE. Some states do not allow the exclusion or limitation of incidental or consequential damages, so the above limitation or exclusion may not apply.

Any implied warranty on these products shall be limited to one year from date of shipment to Purchaser. Some states do not allow limitations on how long an implied warranty lasts, so the above limitations may not apply.

Unless otherwise explicitly agreed in writing, it is understood that these are the only written warranties given by HPS®. Any statements made by any persons including representatives of HPS®, which are inconsistent or in conflict with the terms of the warranty shall not be binding on HPS® unless reduced to writing and approved by an authorized officer of HPS®.

This warranty gives you specific legal rights and you may also have other rights, which may vary, from state to state.

11. Notes
