



HPS™ Products

HPS™ Products Series 903

Inverted Magnetron Transducer
(IMT)

Cold Cathode Ionization

Vacuum Sensor

OPERATION AND MAINTENANCE MANUAL

Please Note:

MKS Instruments provides these documents as the latest version for the revision indicated. The material is subject to change without notice, and should be verified if used in a critical application.





HPS™ Products

HPS™ Products Series 903

Inverted Magnetron Transducer
(IMT)
Cold Cathode Ionization
Vacuum Sensor

JUNE 1999
PART #1090300 REV. A

Part # 1090300XX

— —

Serial # _ _ _ _ _

Please fill in these numbers and have them readily available when calling for service or additional information.

(The part number can be found on your packing slip, and both the part number and serial number are located on the bottom side of the housing.)

For more information or literature, contact:

MKS Instruments, Inc., HPS™ Products, Inc.
5330 Sterling Drive
Boulder, CO 80301 USA

Phone: 303-449-9861
800-345-1967

FAX: 303-442-6880

© 1999 MKS Instruments, Inc. HPS™ Products, Inc., All rights reserved.

ALCONOX is a registered trademark of Alconox, Inc.

IgniTorr is a trademark of MKS Instruments, Inc., HPS™ Products, Inc.

Inconel is a registered trademark of Inco Alloys International, Inc.

Scotch-Brite is a trademark of 3M.

Is a registered trademark of MKS Instruments, Inc., HPS™ Products, Inc.

Table of Contents

Table of Contents	
Package Contents	1
Symbols Used in this Manual	1
Safety Precautions	2
Specifications	3
Feature and Control Locations	5
Typical Applications for the Series 903 (IMT)	6
About the HPS™ Products Series 903 (IMT)	7
Installing the Series 903 (IMT)	8
Location	8
Orientation	8
Contamination	8
Vacuum Connection	9
Electrical Connection	9
Input/Output Wiring	9
Relay Inductive Loads and Arc Suppression	11
Operating the Series 903 (IMT)	12
Starting the (IMT)	12
Reading Pressure	12
Equation for Converting Voltage to Pressure	13
Using the Set Point	13
Venting to Atmosphere	14
Analog-to-Digital (A/D) Converter	14
Preparing for Bakeout	14
Leak Detection	14
Using the Series 903 (IMT) with Other Gases	16
Calibrating for Other Gases	17
Maintaining the Series 903 (IMT)	18
Troubleshooting and Service	18
Contamination of the (IMT) Sensor	19
Disassembly	19
Cleaning	19
Assembly	20

Accessories/Part Replacement	22
Product Warranty	23
Notes	24
Appendix A: How the Series 903 (IMT) Works	A.1
Theory of a Cold Cathode Ionization Sensor	A.1
Notes	A.3

Package Contents

Before unpacking your Series 903 Inverted Magnetron Transducer (IMT) Vacuum Sensor, check all surfaces of the packing material for shipping damage.

Please be sure that your Series 903 (IMT) package contains these items:

- ◆ 1 (IMT) unit (integrated sensor tube and electronics)
- ◆ 1 female, 9-pin subminiature D (D-sub) connector
- ◆ 1 *Series 903 Inverted Magnetron Transducer (IMT) Cold Cathode Ionization Vacuum Sensor User's Manual.*

 If any items are missing from the package, call HPS™ Products Customer Service at 1-303-449-9861 or 1-800-345-1967.

Inspect the (IMT) for visible evidence of damage. If it has been damaged in shipping, notify the carrier immediately. Keep all shipping materials and packaging for claim verification. Do **not** return the product to HPS™.

Symbols Used in this Manual

The first two symbols below, that may be located on your Series 903 (IMT), identify critical safety concerns. They are used throughout this manual to further define the safety concerns associated with the product.

The last two symbols identify other information in this manual that is essential or useful in achieving optimal performance from the (IMT).



CAUTION: Risk of electrical shock.



CAUTION: Refer to manual.

Failure to heed message could result in personal injury or serious damage to the equipment or both.



Failure to heed message could result in damage to the equipment.



Calls attention to important procedures, practices, or conditions.

Safety Precautions



Install the (IMT) only on a grounded vacuum system.

When using an (IMT) with a flange and an elastomer seal, use an all-metal clamp to ensure electrical continuity between the (IMT) and the grounded vacuum system.

When using an (IMT) with a 1-inch tube, use a ground strap to connect the sensor to the grounded vacuum system.



Do not connect power to the (IMT) unless its flange is attached to the vacuum system and the electronics assembly is fastened to the sensor housing.

Do not exceed voltage requirements as this may damage the electronics assembly. Refer to the information on page 9 for proper connection instructions.



The (IMT) may be connected only to devices conforming to the requirements of a secondary extra low voltage in accordance with EN61010-1.



Allow only qualified technicians to service the (IMT).

Users should not remove covers, casings, or plug-in components. Injury may result. Turn off power to the (IMT) before proceeding with maintenance. Only a qualified technician should replace or adjust electronic components.

As much as 4 kV may be present in the (IMT) during operation. The current is limited to 100 mA.

The Series 903 (IMT) must be used as instructed by MKS Instruments, Inc., HPS™ Products Inc., for safe operation. Using or modifying the equipment inconsistent with specifications may render the product's inherent protection useless.

Specifications

Measuring Range	3.0 x 10 ⁻¹⁰ to 5.0 x 10 ⁻³ Torr 3.9 x 10 ⁻¹⁰ to 6.5 x 10 ⁻³ mbar 3.9 x 10 ⁻⁸ to 6.5 x 10 ⁻¹ Pa
Set Point Range	1.0 x 10 ⁻⁹ to 1.0 x 10 ⁻³ Torr 1.3 x 10 ⁻⁹ to 1.3 x 10 ⁻³ mbar 1.3 x 10 ⁻⁷ to 1.3 x 10 ⁻¹ Pa
Repeatability	Approximately ±5%
Calibration Gas	Air/nitrogen
Operating Temperature Range	0° to 50°C (32° to 122°F)
Bakeout Temperature	400°C (752°F) maximum for CF flanged unit; without electronics, cable, or magnet
Relative Humidity	80% maximum for temperatures less than 31°C, decreasing linearly to 50% maximum at 40°C
Altitude	2000 m (6561 ft) maximum
Insulation	Pollution Degree 2
Controls	1 relay set point
Relay Contact Rating	SPDT, 1 A @ 30 VDC, resistive
Relay Hysteresis	150 mV*
Relay Response	< 50 msec (0 to 99%) for DP from 5.0 x 10 ⁻⁸ Torr to 3.0 x 10 ⁻⁴ Torr
Power Requirement	14 to 30 VDC, 150 mA maximum
Output Voltage	1.5 to 8.7 VDC, linear output, 30 W maximum output impedance
Output Load	100 kW nominal 10 kW minimum

*150 mV is equivalent to a change in pressure of 1.41 (or 10^{0.150}) times the set point, e.g., if the relay is set to activate at 2.0 x 10⁻⁶ Torr (5.301 V), it will deactivate at 2.82 x 10⁻⁶ Torr (5.451 V).

Internal Operating Voltage	4 kV maximum current limited to 133 mA
Installation Orientation	Any
Internal Volume	0.9 in. ³ (15.0 cm ³) maximum
Materials Exposed to Vacuum	SS 304, SS 302, aluminum, glass, Inconel® X-750, alumina ceramic
Display	LED indicators for set point (red), high voltage (yellow), and power (green)
Electronic Casing	ABS plastic, UL 94-5V flame rating (with conductive coating)
Casing Dimensions (W x D x H)	5" x 3" x 4.2" (127 mm x 76 mm x 108 mm)
Typical Weight (with CF Flange)	2.3 lb (1.04 kg)
Vacuum Connection	KF 25 KF 40 2¾" CF (rotatable) 1" tubing
CE Certification	EMC Directive General Product Safety Directive

Design and/or specifications subject to change without notice.

Feature and Control Locations

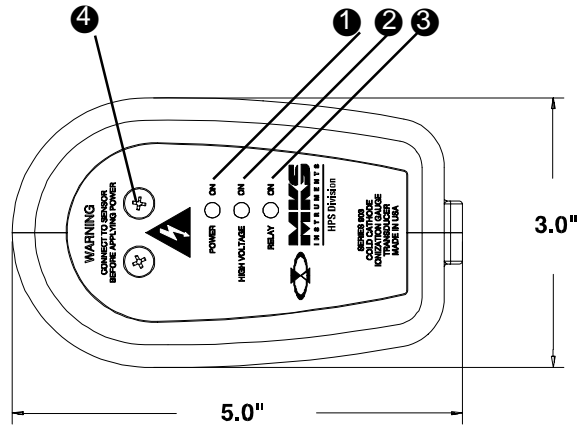

Top View

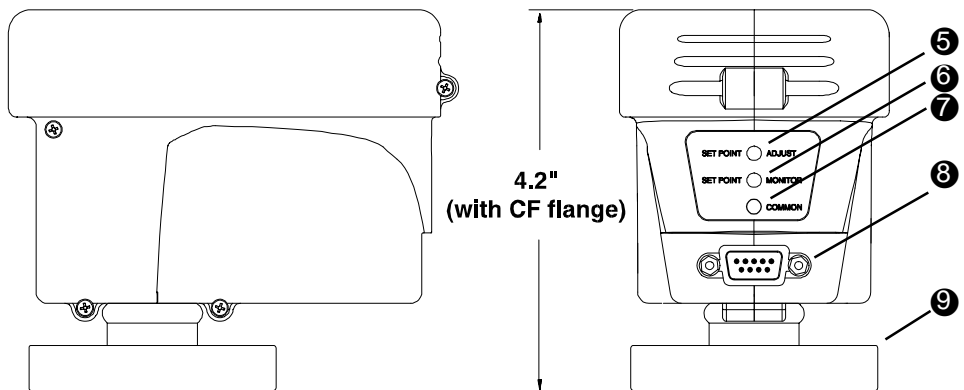

Front View

Side View

- ① LED Power On-Off Indicator (Green)
- ② LED High Voltage Indicator (Yellow)
- ③ LED Set Point Indicator (Red)
- ④ Phillips Head Screws (Access to Sensor Tube)
- ⑤ Set Point Adjustment Potentiometer
- ⑥ Tip Jack for Set Point Monitor
- ⑦ Tip Jack for Common
- ⑧ Male, 9-pin D-sub Connector
- ⑨ Sensor Tube Vacuum Port

Typical Applications for the Series 903 (IMT)

- ◆ ◆ **Measurement of high vacuum** chamber pressures
- ◆ ◆ **Control of high vacuum systems and process sequencing** using the relay set point
- ◆ ◆ **Sensing abnormal pressure** and taking appropriate security measures using the relay set point
- ◆ ◆ **Controlling system pressure** using the analog output as input to an automatic pressure controller
- ◆ ◆ **Starting or stopping system processes** with the relay set point
- ◆ ◆ **Measuring pressures** of backfilled gases
- ◆ ◆ **Leak testing** your vacuum system

About the HPS™ Products Series 903 (IMT)

The Series 903 Inverted Magnetron Transducer (IMT) is a compact cold cathode vacuum sensor with an integrated electronic control circuit.

The (IMT's) simple modular design, high reliability, and low cost make it especially attractive to OEM equipment manufacturers. Its sensor tube is available with one of four standard vacuum interfaces.

The (IMT) is designed for applications which require pressure measurement in the range from 5×10^{-3} down to 3×10^{-10} Torr. Its rapid response and wide measurement range provide the equipment designer with maximum flexibility. Because it can operate autonomously or as part of a control system, it is adaptable to several roles, including that of a monitor or an alarm.

The (IMT) is normally off and requires shorting its *High Voltage Enable* pin to ground to turn it on. This allows the (IMT) to be controlled by a higher pressure sensor such as the HPS™ Products SensaVac Series 907 Analog Convection Transducer (ACT).

For process control, the (IMT) has one adjustable relay set point. An LED indicates the status of the set point.

The (IMT) can be located out of sight — pressure is then read from a standard digital voltmeter or analog-to-digital converter and computer.



Installing the Series 903 (IMT)

Location

Locate the (IMT) where it can measure process chamber or manifold pressure. Install it away from pumps, other vibration sources, and gas sources to give the most representative values.

Orientation

The (IMT) can be installed with the body set in any direction. Operating position does not affect accuracy.

Where space is limited, it may be difficult to position an (IMT) with a CF flange. If the bolts cannot be fed through the flange toward the electronics assembly, it will first be necessary to remove the electronics assembly from the sensor to install the (IMT).

Remove the two Phillips head screws on top of the (IMT) and remove the electronics assembly. Note the alignment of the feed through pins with the orientation of the electronics assembly as shown to the right.

Before assembling the (IMT), inspect the pins to make sure they have not been bent. Straighten them if necessary. The sensor is keyed to the electronics assembly. Rotate the electronics assembly onto the sensor until it is fully seated. Install the two Phillips head screws.

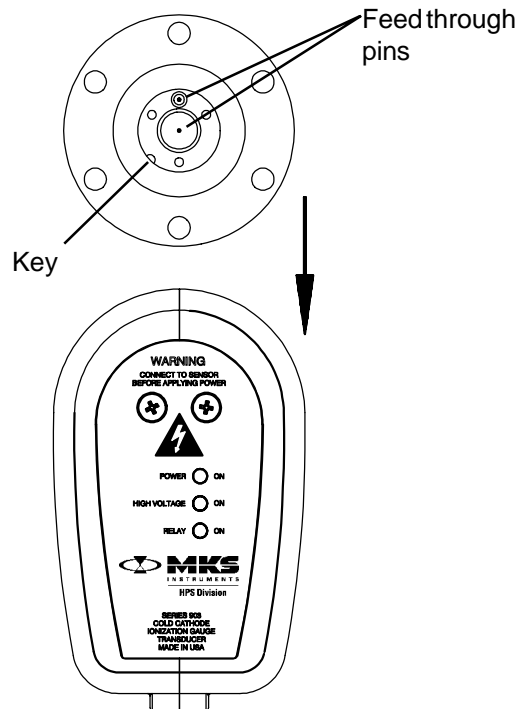

Alignment of sensor with electronics assembly

Contamination

Locate and orient the (IMT) where contamination is least likely. If it is installed directly above a diffusion pump, for example, oil vapor could contaminate the cathode, anode, or other vacuum exposed components, causing the calibration to shift.

Installing it with the vacuum port facing down is preferable as this helps prevent contaminants falling into it.

Operation at pressures above 10^{-3} Torr for extended periods can promote the negative effects of contamination in the sensor.

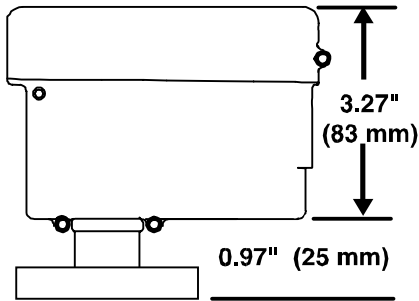

2 3/4" CF

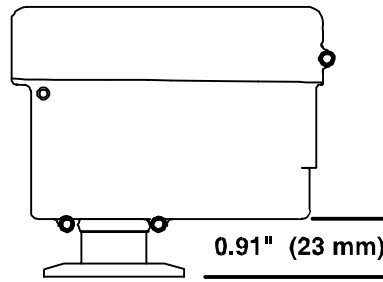

KF 40

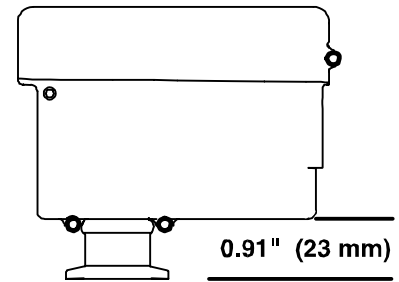

KF 25

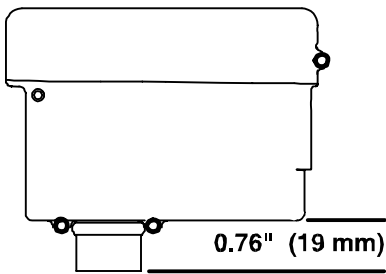

1" tube

Vacuum Connection

Standard (IMT) vacuum interfaces are shown above.

Use an all-metal clamp to mount a KF 25 or KF 40 flanged sensor body.

Electrical Connection

Mount the (IMT) to a grounded vacuum system.

Use a cable with a mating, 9-pin D-sub connector with strain reliefs to ensure proper electrical connection and to reduce stress on the connectors.

Connect the cable to the (IMT) and to your power supply or measuring device before operating the (IMT).



Ensure a low impedance electrical connection between the (IMT) and the grounded vacuum system to shield the sensor from external electromagnetic sources.

Input/Output Wiring

The chart and accompanying figure on the next page identify the pins of the IMT connector and their functions. Make a cable using this information.

To be in compliance with EN 50082-1 immunity requirements, use a braided, shielded cable. Connect the braid to the metal hoods at both ends of the cable with the end for power supply connected to earth ground. The connector kit shipped with the (IMT) includes a metal shell which provides an easy and effective means of connecting the braid to it.

Pin	Description
1	Set point relay - normally open contact
2	Set point relay - normally closed contact
3	Power supply input (+)
4	Power supply input (-)
5	Analog output voltage (+)
6	Set point relay - common
7	Set point relay - disable
8	Analog output voltage (-)
9	High voltage - enable

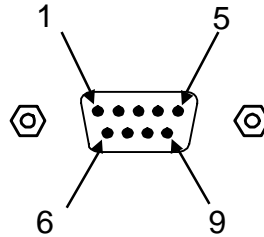

Male, 9-pin D-sub connector

The *power supply input* may range from 14 to 30 VDC. The positive side of the power supply is connected to pin 3 and the negative side to pin 4 of the male D-sub connector.



Damage may occur to the circuitry if excessive voltage is applied or if a wrong connection is made.

The *analog output voltages* are pins 5 (+) and 8 (-). Connect them to a differential input voltmeter or an analog-to-digital (A/D) converter with a differential input in a system controller.



Do not connect the negative side of the analog output, pin 8, to the negative side of the power supply input, pin 4, or to any other ground. Half of the power current would flow through this wire. Measurement errors in the output voltage may be seen due to the voltage drop from this current. The longer the cable, the worse the error will be.

To *enable* the *high voltage* with an external switch, connect pin 9 to the *power supply input* (-), pin 4.

An open connection turns off the high voltage. The high voltage should be turned off at pressures above 10^{-2} Torr to prevent effects of contamination at higher pressures. An output of greater than 9.5 V indicates the high voltage is off and an output of less than 0.5 V indicates no power to the transducer or that discharge has not yet started.

Connect pin 7 to the power supply input (-), pin 4 to *disable* the *set point relay*.



Do not connect the set point relay terminals to the analog output.

Relay Inductive Loads and Arc Suppression

If the set point relay is used to switch inductive loads, e.g. solenoids, relays, transformers, etc., the arcing of the relay contacts might interfere with controller operation or reduce relay contact life. Therefore an arc suppression network, shown schematically below, is recommended. The values of the capacitance C and the resistance R can be calculated by the equations,

$$C = I^2 / (1 \times 10^7) \text{ and } R = E / I^a$$

where,

C is in farads

R is in ohms

I is DC or AC_{peak}
load current in amperes

E is DC or AC_{peak}
source voltage in volts

$$a = 1 + (50/E).$$

Note that,

$$R_{min} = 0.5 \text{ W and } C_{min} = 1.0 \times 10^{-9} \text{ F.}$$

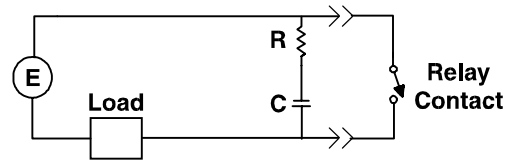

Relay arc suppression network

Operating the Series 903 (IMT)

Starting the (IMT)

The (IMT) starts quickly in low vacuum. In the UHV pressure range, starting may be delayed by several minutes. The SensaVac IgniTorr™ Cold Cathode Starting Device may be used to reduce starting time (see **Accessories**, p. 22).

Reading Pressure

To measure nitrogen gas pressure with the (IMT), turn the power on and start the high voltage. Refer to the graph below, showing pressure as a function of output voltage for nitrogen. To independently convert voltage to pressure, use the equation in the next section.

 **When using the graph, remember that the pressure scale is logarithmic, and the voltage scale is linear. Equal increments of distance along the pressure scale do not correspond to equal pressure changes.**

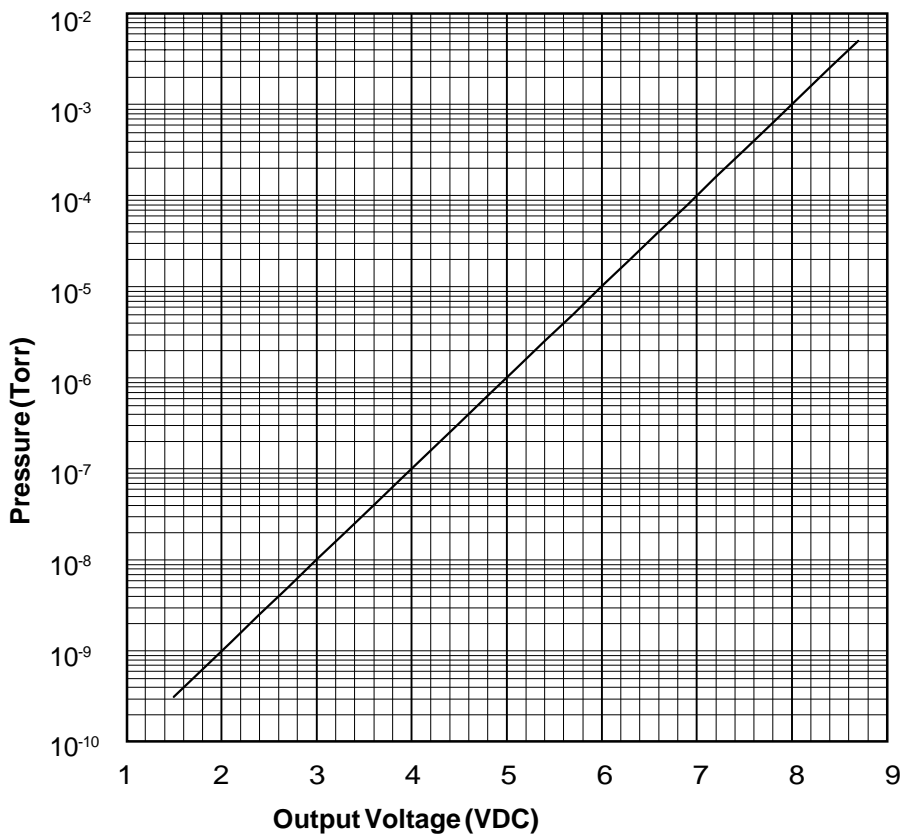

Cold cathode ionization systems are gas dependent and the Series 903 (IMT's) output is defined for air/nitrogen. Refer to page 16, **Using the Series 903 (IMT) with Other Gases**, to determine the true pressure of another gas.

Equation for Converting Voltage to Pressure

The following equation converts the (IMT) voltage reading V to a pressure reading P when using air or nitrogen. The voltage must be within the domain of the equation or an incorrect pressure reading will result.

$$P = 10^{(V-K)}$$

Where,

P is in Torr, mbar, microns, or Pascal (depending on K)

V is in volts for $1.5 \leq V \leq 8.7$

$K = 11.000$ for Torr, 10.875 for mbar,

8.000 for microns, 8.875 for Pascal.

Using the Set Point

Attach a digital voltmeter to the *Common* tip jack and the *Set Point* tip jack on the (IMT) as shown below. Adjust the potentiometer with a small screwdriver until the voltage reading coincides with the desired set point pressure. This pressure is shown on the graph on the previous page or is calculated from the equation above.

When the set point LED is on, the measured pressure is below the set point value, the normally open relay contact is closed, and the normally closed contact is open. When the LED is off, the measured pressure is above the set point value, the normally open relay contact is open, and the normally closed contact is closed. If a power failure occurs, the set point and its LED will turn off.

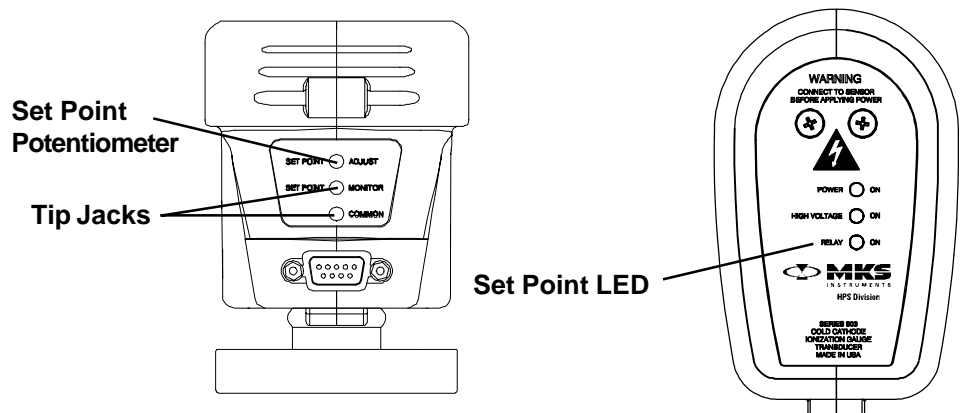

The set point can be turned off by connecting pin 7 (set point disable) to pin 4 (power supply input (-)).



If the high voltage is started in high vacuum and the sensor discharge has not yet begun, the (IMT) will indicate too low of a reading, possibly tripping the set point. In this case, you should deactivate the set point, monitor the reading until the sensor starts, and activate the set point thereafter.

Venting to Atmosphere

While the (IMT) can withstand rapid venting to atmosphere without damage, prolonged operation at pressures above 10^{-3} Torr increases the negative effects of contamination in the sensor. Contamination can result in measurement errors and, in severe cases, instabilities requiring more frequent cleaning of the (IMT).

Analog-to-Digital (A/D) Converter

To take full advantage of the (IMT's) capabilities, an A/D converter with an input voltage span of 0 to 10 V may be used. A resolution of 12 bits is needed, corresponding to 2.44 mV per bit. The A/D converter should have a differential input to ensure accurate measurements.

Preparing for Bakeout

Shut off power to the (IMT) and remove its cable. Remove the two Phillips head screws holding the electronics assembly to the sensor body. The remainder of the Sensor is ready to be baked out to 400°C if using a CF flange or to 150°C if using a KF flange.

Leak Detection

Its inherent sensitivity to gas type makes the Series 903 (IMT) useful for detecting leaks in vacuum systems. It is a good complement to a mass spectrometer leak detector, which locates smaller leaks.

Probe the suspected leak areas with a gas that has an ionization potential different than that of the system gas. Helium or argon gas is suitable for probing a system pumping air or nitrogen.

-
- 1) Pump your vacuum system to a base pressure.
 - 2) Slowly and methodically probe with a small amount of gas.



Flooding the leak or moving quickly past the leak can confuse the search since time lags may be significant.

- 3) Note the pressure reading.

The pressure will either rise or fall, depending upon the ionization potential of the probe gas relative to the system gas. The largest change in value indicates the probe gas is nearest the leak location.

- 4) Repeat the test to confirm.

Using the Series 903 (IMT) with Other Gases



Before using the (IMT) to measure pressure of gases other than air or nitrogen, you should read and understand this section. To answer further questions, contact Applications Engineering at HPS™ Products at 1-303-449-9861 or 1-800-345-1967.

In a cold cathode ionization sensor, the degree of ionization, hence the indicated pressure, is gas-type dependent. (see page A.1, **Theory of a Cold Cathode Ionization Sensor.**)

The Series 903 (IMT) is calibrated to give a voltage output for air or nitrogen according to the graph on page 12 or the equation on page 13. If used with another gas, the (IMT) will give an output which corresponds to the ionization from the sensor for nitrogen. This is the *nitrogen equivalent pressure*, or indicated pressure of the gas, which may be higher or lower than its true pressure. True-versus-indicated-pressure curves for some common gases are shown below.

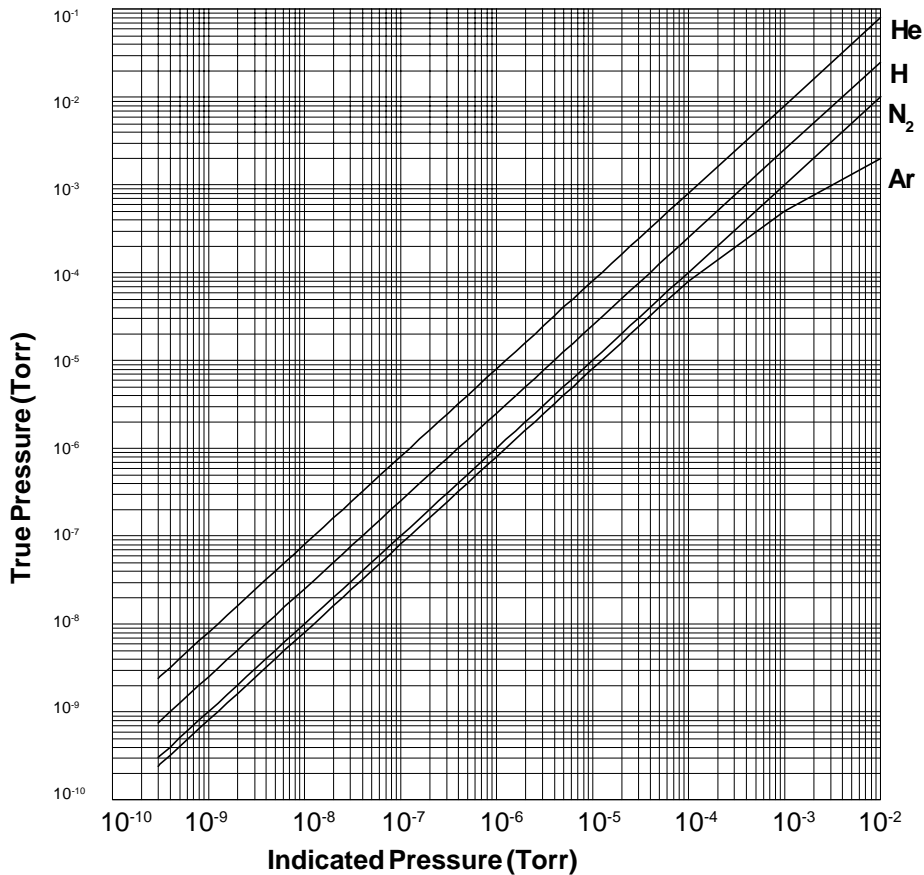

Below is a table which shows the correction factors needed to obtain curves for selected gases other than air/nitrogen. You can make your own graph from this information or use the graph on the previous page which shows the same information.

Table of Correction Factors	
$P_{H_2} = P_{Indicated} \times 2.5$	
$P_{He} = P_{Indicated} \times 8$	
$P_{Ar} = P_{Indicated} \times 0.8$ below 10^{-4}	
$P_{Ar} = P_{Indicated} \times 0.5$ at 10^{-3}	
$P_{Ar} = P_{Indicated} \times 0.2$ at 10^{-2}	

Calibrating for Other Gases

Air calibration is indistinguishable from nitrogen. To determine the voltage/pressure relationship for a gas which is not shown on the graph on the previous page, you need to calibrate the (IMT). This requires a gas independent sensor, such as a capacitance manometer or spinning rotor gauge, to act as the calibration standard. A curve can then be generated.



The Series 903 (IMT) cannot be calibrated for direct pressure readings of gases other than air or nitrogen. The calibration is intended only to match the air/nitrogen curve of the sensor.

Gas-type dependence can either be an advantage or a disadvantage. On the one hand, it's possible to use a cold cathode sensor as a leak detector. On the other hand, the pressure indication of a gas may vary by a factor of five or more.

Also, calibration factors, or relative sensitivity factors, for cold cathode ionization sensors are not the same as those for hot cathode sensors.

Maintaining the Series 903 (IMT)

Troubleshooting and Service

The Series 903 (IMT) is designed to be maintenance-free under normal operation. If a problem should occur, the following chart lists symptoms, possible causes, and their remedies. With this guide, you should be able to diagnose some problems and correct them. Those which fall outside the scope of this chart or problems related to the electronics assembly are generally not serviceable by the user, and the (IMT) should be returned to HPS™ Products for repair.

Troubleshooting Chart		
Symptom	Possible Cause	Remedy
Pressure readings are too erratic.	1. Contaminated sensor.	1. Inspect and clean if necessary. Refer to page 19.
No analog output voltage.	1. D-sub is disconnected. 2. Power supply turned off. 3. Defective PC board.	1. Connect D-sub. 2. Turn power on. 3. Return to HPS™ for repair.
Analog output voltage higher than 9.5 V.	1. High voltage is turned off.	1. Connect pin 9 to pin 4. Refer to page 9, Input/Output Wiring .
Analog output voltage less than 1.5 V.	1. Discharge has not started. 2. Pressure is less than 3×10^{-10} Torr	1. Wait for discharge to start or increase pressure to speed up starting time. Consider purchasing an IgniTorr™. 2. Beyond range. Increase pressure if desired.
Analog output voltage less than 0.5 V and LED off.	1. No supply voltage. 2. Power supply turned off.	1. Check cable connection. 2. Turn power on.
Analog output voltage less than 0.5 V and LED on.	1. Supply voltage too low.	1. Increase supply voltage to provide 14 to 30 V at the (IMT).
Set point relay will not operate.	1. Set point voltage incorrectly set. 2. Pin 7 of D-sub connected to ground at power supply. 3. Defective PC Board.	1. Check set point. 2. Check any external switches which may be controlling this line. 3. Return to HPS™ for repair.

Contamination of the (IMT) Sensor

If pressure readings appear to be erratic, the sensor tube may be contaminated. Inspect it visually. If contamination is visible, you should replace the internal components with an Internal Rebuild Kit or a Rebuild Sensor (see **Accessories**, p. 22).

Depending on the degree of contamination and application of the (IMT), the internal parts may be cleaned — either ultrasonically, with mild abrasives, or chemically.



For the remaining sections, please refer to the figure shown on page 21.

Disassembly

Tools required: Phillips head screwdriver; clean tweezers; clean, smooth-jaw, needle-nose pliers

- 1) Remove the two Phillips head screws holding the electronics assembly to the sensor body. Remove the electronics assembly.
- 2) Using the smooth-jaw, needle-nose pliers, firmly grab the *compression spring* ① at the tip closest to the flange.
- 3) Pull on the *compression spring* while rotating it to free it from the formed *groove* ⑦ of the *sensor body* ⑧. Continue to pull until the *compression spring* is completely free.
- 4) Carefully remove the remaining components from the *sensor body*.



Do not bend the anode ⑨ or the leaf spring ⑩ on the ion current feed through pin ⑭ when assembling or disassembling the sensor.

Cleaning

If **cleaning ultrasonically**, use high quality detergents compatible with aluminum, such as ALCONOX®.

Scrubbing with mild abrasives can remove most contamination. Scotch-Brite™ or a fine emery cloth may be effective. Rinse with alcohol to remove particulates.

Clean aluminum and ceramic parts chemically in a wash, such as a 5 to 20% sodium hydroxide solution (not for semiconductor processing), at room temperature (20°C) for one minute. Follow with a preliminary rinse of deionized water. Remove smut (the black residue left on aluminum parts due to this process) in a 50 to 70% nitric acid dip for about 5 minutes.



Chemical cleaning should not be used to clean the anode; mild abrasives or ultrasonic cleaning are acceptable.



Do not damage the leaf spring while cleaning the Sensor.

Each of the above cleaning methods should be followed with multiple rinses of deionized water.

Dry all internal components and the *sensor body* ⑧ in a clean oven. The two *ceramic spacers* ②, ⑤ are slightly porous and will require longer drying time to drive off the absorbed water.

Assembly

Wear gloves and assemble with clean tools.

Check the *anode* ⑨. It should be straight and centered with the *sensor body* ⑧ for proper operation. Roll the *sensor body* on a flat surface and look for any radial run out motion.

- 1) Install the *ground shield* ⑥ using tweezers. Make sure that, at the groove of its larger diameter, the *ground shield* interlocks with the *locating collar* ⑫ .
- 2) Slide the *small ceramic spacer* ⑤ over the small end of the *ground shield* ⑥ . Check that the *leaf spring* ⑩ will contact the base of the *cathode* ④ as shown to the right. If not, remove the *small ceramic spacer* and the *ground shield*, and gently bend the *leaf spring* towards the *anode* ⑨ and then replace the *ground shield* and *ceramic spacer*.
- 3) Slide the *cathode* ④, the *grid washer* ③, and the *large ceramic spacer* ② into place. The *grid washer* has a concave shape. Refer to the figure to see its installation orientation.
- 4) Insert the small end of the *compression spring* ① into the *sensor body* ⑧. Using your thumbs, push the larger end of the spring into the *sensor body* until it is contained within the tube. Using the smooth-jaw, needle-nose pliers, work the *compression spring* down into the *sensor body* until it is fully seated in the formed groove.
- 5) Inspect the *ground shield* ⑥ and the *grid washer* ③ to verify they are centered with respect to the *anode* ⑨. If adjustment is needed, gently reposition the grid washer/cathode assembly, taking care not to scratch the *grid washer*.



HPS™ suggests you measure the resistance between the ion current feed through pin ⑭ and the grid washer ③ to verify that the leaf spring ⑩ is in contact with the cathode ④. The measurement should indicate a short circuit between them. There should be an open circuit between the ion current feed through pin ⑭ and both the high voltage feed through pin ⑪ and sensor body ⑧.

The (IMT) is ready for installation. If it is not immediately installed, cover the flange with clean, vacuum-grade aluminum foil and cap it with a flange protector.

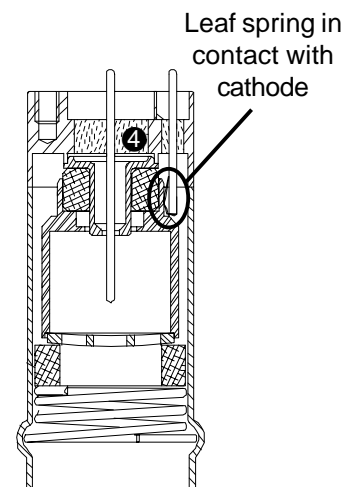

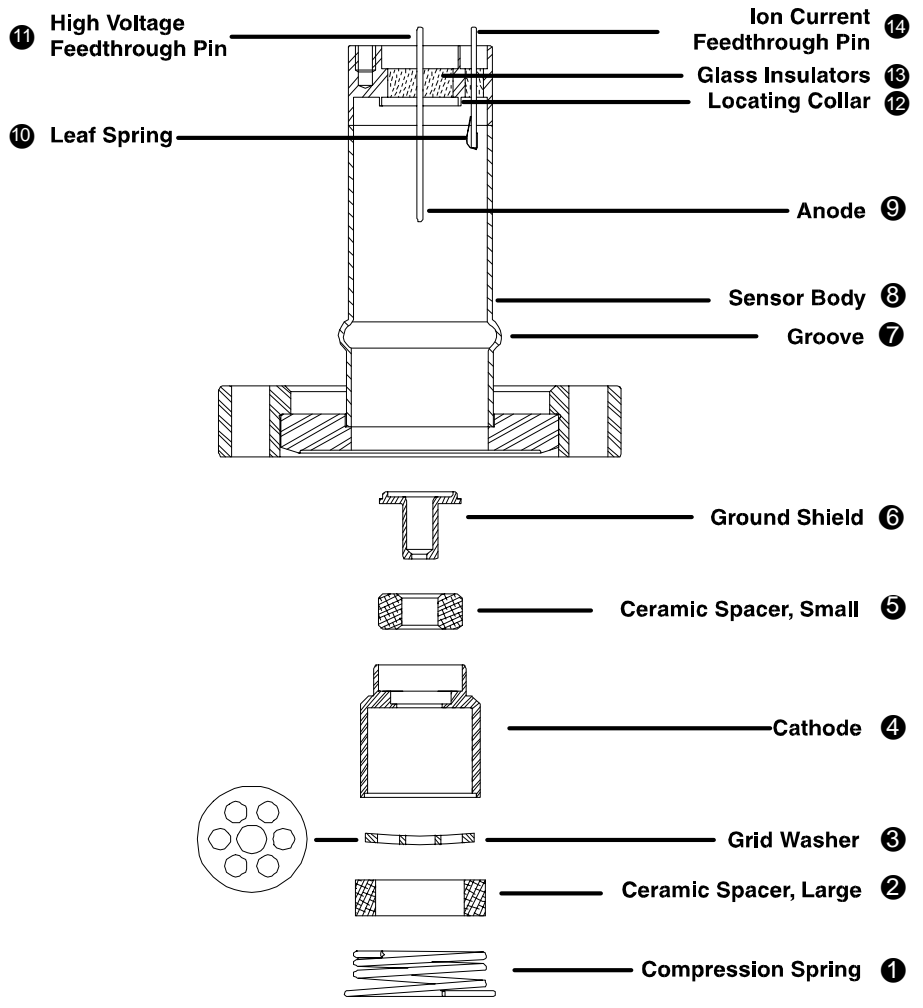

Accessories/Part Replacement

	<i>Part #</i>
IgniTorr™ Cold Cathode Starting Device	
<i>(for use with CF flange only)</i>	
120V	100006850
220V	100007090
Internal Rebuild Kit	100002353
<i>Cathode, Grid Washer, Ground Shield, 1 Small and 1 Large Ceramic Spacer, Spring</i>	
Rebuild Sensor	
KF 40	104230101
2¾" CF	104230102
1" Tube	104230103
KF 25	104230104
HPS™ Series 903 Inverted Magnetron Transducer (IMT) Cold Cathode Ionization Vacuum Sensor User's Manual	109030025

Please call HPS™ Products Customer Service Department at 1-303-449-9861 or 1-800-345-1967 to order any of these parts or to receive catalogs for other HPS™ Products.

Product Warranty

Extent of the Warranty

MKS Instruments, Inc. HPS™ Products, Inc., warrants the HPS™ Products Series 903 Inverted Magnetron Transducer (IMT) Vacuum Sensor and its accessories to be free from defects in materials and workmanship for one (1) year from the date of shipment by HPS™ or authorized representative to the original purchaser (PURCHASER). Any product or parts of the product repaired or replaced by HPS™ under this warranty are warranted only for the remaining unexpired part of its one (1) year original warranty period. After expiration of the applicable warranty period, the PURCHASER shall be charged HPS™ current prices for parts and labor, plus any transportation for any repairs or replacement.

ALL EXPRESS AND IMPLIED WARRANTIES, INCLUDING THE IMPLIED WARRANTIES OF MERCHANTABILITY AND FITNESS FOR A PARTICULAR PURPOSE, ARE LIMITED TO THE WARRANTY PERIOD. NO WARRANTIES, EXPRESS OR IMPLIED, WILL APPLY AFTER THIS PERIOD.

Warranty Service

The obligations of HPS™ under this warranty shall be at its option: (1) to repair, replace, or adjust the product so that it meets applicable product specifications published by HPS™ or (2) to refund the purchase price.

What Is Not Covered

The product is subject to above terms only if located in the country of the seller from whom the product was purchased. The above warranties do not apply to:

- I. Damages or malfunctions due to failure to provide reasonable and necessary maintenance in accordance with HPS™ operating instructions.
- II. Damages or malfunctions due to chemical or electrolytic influences or use of the product in working environments outside the specification.
- III. Fuses and all expendable items which by their nature or limited lifetime may not function for a year. If such items fail to give reasonable service for a reasonable period of time within the warranty period of the product; they will, at the option of HPS™, be repaired or replaced.
- IV. Defects or damages caused by modifications and repairs effected by the original PURCHASER or third parties not authorized in the manual.

Condition of Returned Products

HPS™ will not accept for repair, replacement, or credit any product which is asserted to be defective by the PURCHASER, or any product for which paid or unpaid service is desired, if the product is contaminated with potentially corrosive, reactive, harmful, or radioactive materials, gases, or chemicals. When products are used with toxic chemicals, or in an atmosphere that is dangerous to the health of humans, or is environmentally unsafe, it is the responsibility of the PURCHASER to have the product cleaned by an independent agency skilled and approved in the handling and cleaning of contaminated materials before the product will be accepted by HPS™ for repair and/or replacement. In the course of implementing this policy, HPS™ Customer Service Personnel may inquire of the PURCHASER whether the product has been contaminated with or exposed to potentially corrosive, reactive, harmful, or radioactive materials, gases, or chemicals when the PURCHASER requests a return authorization. Notwithstanding such inquiries, it is the responsibility of the PURCHASER to ensure that no products are returned to HPS which have been contaminated in the aforementioned manner.

Other Rights and Remedies

- I. These remedies are exclusive. HPS™ SHALL NOT BE LIABLE FOR CONSEQUENTIAL DAMAGES, FOR ANTICIPATED OR LOST PROFITS, INCIDENTAL DAMAGES OR LOSS OF TIME, OR OTHER LOSSES INCURRED BY THE PURCHASER OR BY ANY THIRD PARTY IN CONNECTION WITH THE PRODUCT COVERED BY THIS WARRANTY, OR OTHERWISE. Some states do not allow exclusion or limitation of incidental or consequential damage or do not allow the limitation on how long an implied warranty lasts. If such laws apply, the limitations or exclusions expressed herein may not apply to PURCHASER.
- II. Unless otherwise explicitly agreed in writing, it is understood that these are the only written warranties given by HPS™. Any statements made by any persons, including representatives of HPS™, which are inconsistent or in conflict with the terms of the warranty shall not be binding on HPS™ unless reduced to writing and approved by an authorized officer of HPS™.
- III. This warranty gives PURCHASER specific legal rights, and PURCHASER may also have other rights which vary from state to state.
- IV. For HPS™ products sold outside of the U.S., contact your MKS representative for warranty information and service.

Warranty Performance

To obtain warranty satisfaction, contact the following: MKS Instruments, Inc., HPS™ Products, Inc., 5330 Sterling Drive, Boulder, CO 80301, USA, at phone number (303) 449-9861. You may be required to present proof of original purchase.



Notes

Appendix A: How the Series 903 (IMT) Works

Theory of a Cold Cathode Ionization Sensor

A cold cathode ionization sensor has a number of inherent advantages over a hot cathode sensor. These include:

- ◆ No filament to burn out, which makes it immune to inrushes of air, and it is relatively insensitive to vibration damage
- ◆ No x-ray limit for lower pressure measurement
- ◆ No adjustment for emission current or filament voltage is needed
- ◆ Since heating or degassing is not needed, there is little effect on the system
- ◆ Properly designed sensor tubes can be cleaned and reused almost indefinitely
- ◆ With only one current loop, the control circuit is simple and quite reliable, as opposed to a hot cathode sensor, which has three.

The cold cathode magnetic discharge sensor consists of a cathode and anode with a potential difference of several kilovolts. The electrodes are surrounded by a magnetic field, arranged so that the magnetic field is essentially perpendicular to the electric field. The crossed electric and magnetic fields cause the electrons to follow long spiral trajectories increasing the chance of collisions with gas molecules, thereby providing a significant increase in ionization efficiency relative to a hot cathode sensor.

In operation, a near constant circulating electron current is trapped by the crossed fields. Collisions of electrons with residual gas molecules produce ions which are collected by the cathode. The sensor current i as a function of pressure P obeys the relationship:

$$i = kP^n$$

where,

k is a constant

P is in Torr

n is a constant, usually in the range of 1.00 to 1.15.

This equation is valid for the pressure range from 10^{-3} Torr down to 10^{-8} Torr depending upon the series resistor used. Sensitivities of 1 to 10 amperes/Torr are not unusual.

Starting a cold cathode sensor depends upon some chance event such as field emission or a cosmic ray producing the first electron. This produces additional electron/ion pairs during its transit between the electrodes, and the discharge soon builds up to a stable value. Start of the discharge normally requires a very short time at 10^{-6} Torr or above, a few minutes at 10^{-8} Torr, and longer times at lower pressures.

If the series resistor is small, e.g. 1 MW, the current at high pressures increases, and sputtering of the cathode can become a problem. A larger series resistor reduces sputtering, and the voltage across the tube is pressure dependent between 10^{-4} and 10^{-2} Torr. This extends the measuring range of the cold cathode to 10^{-2} Torr.

Because of the difficulty in maintaining the discharge at low pressures, sensors of the loop anode design do not work well below 10^{-6} Torr. To reduce this problem, a cylindrical anode, cathode plates at each end, and a cylindrical magnet are used. During the 1950s, the inverted magnetron sensor was developed, which uses auxiliary cathodes and is able to measure pressures below 10^{-12} Torr.

Many electrode arrangements have been used in cold cathode sensors. Single feedthrough cold cathode sensors often suffer from spurious currents due to insulator leakage and field emission, which mask the small pressure dependent ionization currents. The (IMT) uses an inverted magnetron to reduce these problems by using separate feedthroughs for the anode high voltage and the cathode current. This geometry uses a cylindrical cathode, a central wire anode, and external cylindrical magnet which provides an axial field. The cathode is insulated from the grounded metal housing.

The inverted magnetron geometry has a characteristic *electrical conductance vs. pressure* curve which is more reproducible than other arrangements, and also works well to low pressures without risk of the discharge going out. This gives the (IMT) a measuring range from 5×10^{-3} to 3×10^{-10} Torr.

Notes



