



**971 UniMag™
Vacuum pressure transducer
RS232 / RS485 / Display
Operation and Installation Manual**

P/N: 100017131
971 UniMag™ Transducer
Operation and Installation Manual
Revision: C, January, 2010

Extent of the Warranty

MKS Instruments, Inc., HPS™ Products Inc. and MKS Denmark ApS. warrants the 971 UniMag Vacuum Transducer and its accessories to be free from defects in materials and workmanship for one (1) year from the date of shipment by HPS™ or authorized representative to the original purchaser (PURCHASER). Any product or parts of the product repaired or replaced by HPS™ under this warranty are warranted only for the remaining unexpired part of its one (1) year original warranty period. After expiration of the applicable warranty period, the PURCHASER shall be charged HPS™' current prices for parts and labour, plus any transportation for any repairs or replacement. ALL EXPRESS AND IMPLIED WARRANTIES, INCLUDING THE IMPLIED WARRANTIES OF MERCHANTABILITY AND FITNESS FOR A PARTICULAR PURPOSE, ARE LIMITED TO THE WARRANTY PERIOD. NO WARRANTIES, EXPRESS OR IMPLIED, WILL APPLY AFTER THIS PERIOD.

Warranty Service

The obligations of HPS™ under this warranty shall be at its option: (1) to repair, replace, or adjust the product so that it meets applicable product specifications published by HPS™ or (2) to refund the purchase price.

What Is Not Covered

The product is subject to above terms only if located in the country of the seller from whom the product was purchased. The above warranties do not apply to:

- I. Damages or malfunctions due to failure to provide reasonable and necessary maintenance in accordance with HPS™ operating instructions.
- II. Damages or malfunctions due to chemical or electrolytic influences or use of the product in working environments outside the specification.
- III. Fuses and all expendable items which by their nature or limited lifetime may not function for a year. If such items fail to give reasonable service for a reasonable period of time within the warranty period of the product; they will, at the option of HPS™, be repaired or replaced.
- IV. Defects or damages caused by modifications and repairs effected by the original PURCHASER or third parties not authorized in the manual.

Condition of Returned Products

HPS™ will not accept for repair, replacement, or credit any product which is asserted to be defective by the PURCHASER, or any product for which paid or unpaid service is desired, if the product is contaminated with potentially corrosive, reactive, harmful, or radioactive materials, gases, or chemicals. When products are used with toxic chemicals, or in an atmosphere that is dangerous to the health of humans, or is environmentally unsafe, it is the responsibility of the PURCHASER to have the product cleaned by an independent agency skilled and approved in the handling and cleaning of contaminated materials before the product will be accepted by HPS™ for repair and/or replacement. In the course of implementing this policy, HPS™ Customer Service Personnel may inquire of the PURCHASER whether the product has been contaminated with or exposed to potentially corrosive, reactive, harmful, or radioactive materials, gases, or chemicals when the PURCHASER requests a return authorization. Notwithstanding such inquiries, it is the responsibility of the PURCHASER to ensure that no products are returned to HPS™ which have been contaminated in the aforementioned manner.

Other Rights and Remedies

- I. These remedies are exclusive. HPS™ SHALL NOT BE LIABLE FOR CONSEQUENTIAL DAMAGES, FOR ANTICIPATED OR LOST PROFITS, INCIDENTAL DAMAGES OR LOSS OF TIME, OR OTHER LOSSES INCURRED BY THE PURCHASER OR BY ANY THIRD PARTY IN CONNECTION WITH THE PRODUCT COVERED BY THIS WARRANTY, OR OTHERWISE. Some states do not allow exclusion or limitation of incidental or consequential damage or do not allow the limitation on how long an implied warranty lasts. If such laws apply, the limitations or exclusions expressed herein may not apply to PURCHASER.
- II. Unless otherwise explicitly agreed in writing, it is understood that these are the only written warranties given by HPS™. Any statements made by any persons, including representatives of HPS™, which are inconsistent or in conflict with the terms of the warranty shall not be binding on HPS™ unless reduced to writing and approved by an authorized officer of HPS™.
- III. This warranty gives PURCHASER specific legal rights, and PURCHASER may also have other rights which vary from state to state.
- IV. For HPS™ products sold outside of the U.S., contact your MKS representative for warranty information and service.

Warranty Performance

To obtain warranty satisfaction, contact the following:

US & ASIA:

MKS Instruments, Inc., HPS™ Products, Inc., 5330 Sterling Drive, Boulder, CO 80301, USA, Phone: (303) 449-9861.

EUROPE:

MKS Denmark ApS, Ndr. Strandvej 119G, DK3150 Hellebaek, Denmark, Phone: +45 44 92 92 99, E-mail: mksdenmark@mksinst.com

Part number: 972-_____

Serial number: _____

Please fill in these numbers and have them readily available when calling for service or additional information. The part number can be found on your packing slip, and both the part number and serial number are located on the side of the housing.



This manual is valid for products with serial number 1000127491 and higher.

© 2009 MKS Instruments. All rights reserved.

Trademarks used in this manual: HPS™, Baratron®, UniMag™, DualTrans™, MicroPirani™ and Quattro™ are trademarks of MKS Instruments Inc. Windows® is a trademark of Microsoft Corporation. Viton® is a trademark of DuPont Performance Elastomers L.L.C.

Table of Contents

Safety information	2
Symbols used:	2
Unpacking	3
Description	4
971 Functions	5
User Switch	5
LED Status Indicator	5
Transducer installation (mechanical)	6
Transducer installation (electrical)	7
Serial user interface	9
Communication Protocol	10
Setpoint relays	12
Calibration and adjustment	17
Factory default	18
Transducer lock function	19
User Switch Command	19
Transducer test	19
Status Query Commands	20
Analog output	21
Query Command list	26
Setup and configuration command list	27
FAQ (Frequently Asked Questions)	28
Trouble shooting	30
Service and Repair	31
Specifications	32
Accessories and replacement part numbers	35
CE Declaration of Conformity	36
Notes	38
Index	40

For more information contact:

MKS Denmark ApS.
Ndr. Strandvej 119G
DK-3150 Hellebaek
Denmark



Tel: +45 44 92 92 99 – Fax: +45 44 92 94 99
E-mail: mksdenmark@mksinst.com

MKS Instruments, HPS Products
5330 Sterling Dr.
Boulder, CO 80301
USA
Tel: 303 449 9861 Fax: 303 449 2003

Safety information:

Symbols used:







The first symbol below is used throughout this manual to further define the safety concerns associated with the product. The last two symbols identify other information in this manual that is essential or useful in achieving optimal performance from the 971 UniMag transducer.

Caution:		Refer to manual. Failure to read message could result in personal injury or serious damage to the equipment or both.
Critical:		Failure to read message could result in damage to the equipment.
Attention:		Calls attention to important procedures, practices or conditions.

General safety information

The safety instructions should always be followed during installation and operation of the 971 UniMag transducer. Pass safety information to all users.

Safety Precautions:

	Electrical connections. The 971 must be properly electrically connected in order to perform according to the specifications. Output pins are not protected against wrong electrical connections. Wrong electrical connections can cause permanent damage to the transducer or interference to measuring performance. Refer to Electrical connections description page 7.
	Fuse. The 971 power supply input has an internal thermal fuse. The fuse is self recoverable and should not be changed.
	Explosive Environments. Do not use the 971 in presence of flammable gases or other explosive environments. Corrosive Environments. The 971 is not intended for use in corrosive environments. Refer to Transducer installation page 6.
	Service and Repair. Do not substitute parts or modify instrument other than described in Service and Repair page 31. Do not install substituted parts or perform any unauthorized modification to the instrument. Return the instrument to a MKS Calibration and Service Center for service and repair to ensure all of the safety features are maintained.
	Magnetic interference. The 971 contains a strong permanent magnet that can interfere with performance and operation of other electronics equipment and life support devices like pacemakers. Only install the 971 where it cannot interfere with other electronics.
	CE marking The 971 transducer complies with European standards for CE marking. Refer to Declaration of Conformity page 36. 

Unpacking

Before unpacking your 971 UniMag transducer, check all surfaces of the packing material for shipping damage. Inspect for visible damage. If found, notify the carrier immediately.

Please be sure that your 971 package contains these items:

Part number	Description
971-xxxxx	971 Transducer
100017130	Short form manual
100017096	Documentation & Software CD

If any items are missing, please call MKS Customer Service at (800)345-1967 or (303)449-9861 or your local MKS sales office or distributor.

Part number

The 971 UniMag part number system has 5 digits that identify flange, communication interface, analog output type, I/O connector and sensor sealing type. Transducers can be delivered with customer configuration of various parameters like setpoint settings and these specials have additional 4 digits after the regular part number.

	Flange	Interface	Analog out	Connector Relays	Enclosure sealing
971-	1	1	0	2	0
					0 Standard / viton sealing
					2 SUBD 15pinHD male / no relay
					3 SUBD 15pinHD male / 3 relays
					5 SUBD 15pinHD male / 3 relays / Dual Aout
					8 RJ45/FCC68 8 pin (Edwards type)
					9 Hirschmann 6 pin (Pfeiffer / Inficon type)
					0 Standard mks
					1 Edwards APG-L
					3 Edwards WRG
					5 Inficon MPG400 / Pfeiffer PKR251
					6 Inficon BPG400 (999 DAC2)
					1 RS232 / Analog
					2 RS485 / Analog
					0 Custom
					2 KF25
					7 CF2.75
					9 KF40

Special versions

Part number

971-x1090-0001 Pfeiffer IKR251 pin and output compatible
 971-x1080-0002 Edwards AIM-S pin and output compatible
 971-x1080-0003 Edwards AIM-X pin and output compatible

Description

The 971 UniMag™ vacuum transducer offers a wide measuring range from 1×10^{-8} to 5×10^{-3} Torr and is based on measurement of cold cathode ionization current.



The 971 is designed for general purpose pressure measurement and control as a standalone unit or with the PDR900 display and controller unit. The transducer uses RS232 or RS485 digital communication interface for setup of transducer parameters and to provide real time pressure measurement.



The 971 has up to three mechanical relays which can be used for process control, for example interlocking valves or pumps. The analog voltage output can be interfaced to external analog equipment for pressure readout or control.

Sensor technology

The cold cathode inverted magnetron utilizes a high voltage anode, cathode and a permanent magnet. Electrons are accelerated towards the anode and will ionize molecules by collision. The magnetic field deflects the electrons, causing them to spiral as they move across the magnetic field to the anode. This spiraling movement increases the opportunity for them to encounter and ionize the molecules. The ionization of the molecules creates an electric current as a function of the pressure.

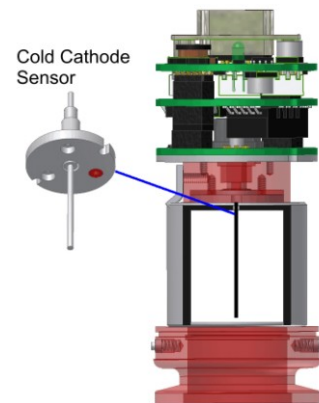

Applications

The 971 can be used in many different vacuum applications within the semiconductor, analytical and coating industries:

- General vacuum pressure measurement
- Coating
- Mass spectrometer control
- System process control
- Sense abnormal pressure and take appropriate security measures using set point relays
- Control system base pressure

Disposal (European Union only)

The 971 transducer is manufactured according to the RoHS directive.



For the benefit of the environment, at the end of life of the 971, it should not be disposed in the normal unsorted waste stream. It should be deposited at an appropriate collection point or facility to enable recovery or recycling.



971 Functions

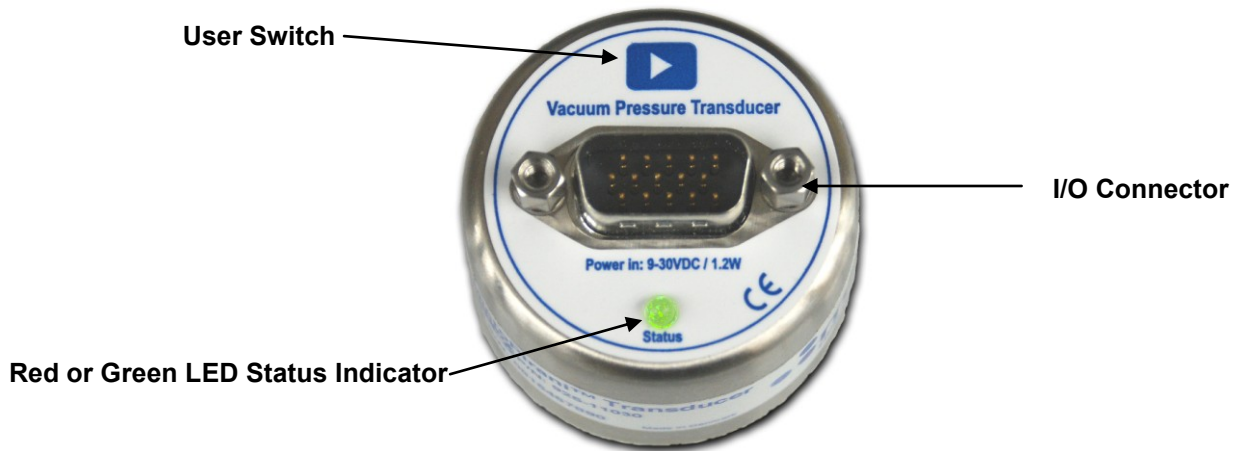

User Switch

The user switch turns on cold cathode sensor.

Refer to pages 15 for operation procedure.



The cold cathode sensor should only be turned on when vacuum pressure is below 5×10^{-3} Torr



If the transducer is delivered with customer specified parameters the User Switch is disabled. For enabling the switch see page 19.

LED Status Indicator

The red/green LED status indicator has the following stages:

- | | |
|-------------------------------|--|
| 1. GREEN | Normal operation |
| 2. 2 sec. RED | Power on sequence |
| 3. GREEN 1 sec. flash cycle | Test mode TST!ON (see page 19) |
| 4. GREEN 0.5 sec. flash cycle | Cold Cathode high voltage turned on |
| 5. Red 0.5 sec. flash cycle | Cold Cathode high voltage turned on, but ionization has not started. |
| 6. RED | Sensor failure (see page 31) |
| 7. OFF | Power off |

Transducer installation (mechanical)



Do not use or install the 971 transducer where the following conditions occur:

- Temperatures lower than 0 °C or higher than 40 °C
 - Corrosive or explosive gases
 - Direct sunlight or other heat sources
 - Magnetic fields
-

Process compatibility

The 971 transducer is intended for use in relatively clean environments.

If the 971 transducer is located close to a gas source connection like a flow controller or leak valve the transducer pressure measurement can be higher than the actual chamber pressure. Location close to a pumping system connection can cause a lower pressure measurement than actual chamber pressure.

The 971 transducer and its sensor design can be mounted in any orientation without compromising accuracy.

Explosive Environments

The 971 should not be used in explosive environments, due to its high voltage potential that can cause ignition.

Temperature

For best measuring performance avoid large temperature gradients and direct cooling like air-condition air stream or direct heating like a pump exhaust stream.

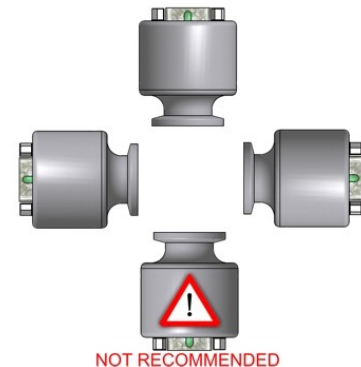

Bake out

The transducer electronics can withstand 85 °C (185 °F) when the power is turned off.

Contamination

Locate and orient the 971 where contamination is least likely.



If the transducer is backfilled with a liquid (like pump oil) the sensor can be cleaned. Refer to Service and Maintenance page 31.

Vacuum connections

The 971 transducer is available with different types of vacuum fittings. When mounting the transducer always ensure that all vacuum sealing items and surfaces are clean, without damage and free of particles. Do not touch the vacuum flange sealing surface.



If the transducer will be exposed to pressures above atmospheric pressure make sure that proper vacuum fittings are used. Ensure that the internal system pressure is at ambient pressure conditions before opening the vacuum system and removing any connections.

Pressure range

The standard 971 transducer is internally sealed with elastomer viton sealing for use down to 1×10^{-8} Torr. The 971 can be exposed to positive pressure up to 3000 Torr absolute.

Transducer installation (electrical)

The 971 is available with different input/output connectors. Use a cable with strain relief to ensure proper electrical connection and to reduce stress on the connectors.



Ensure a low impedance electrical connection between the 971 transducer body and the grounded vacuum system to shield the sensor from external electromagnetic sources.

Ensure that the analog output is connected to a floating input.

To comply with EN61326-1 immunity requirements, use a braided shielded cable. Connect the braid to the metal hoods at both ends of the cable with the end for power supply connected to earth ground.

The power supply input is 9 to 30 VDC. The power supply input is protected by an internal thermal fuse. The fuse is self recoverable; do not replace it. Damage may occur to the circuitry if excessive voltage is applied, polarity reversed or if a wrong connection is made.

If using the analog voltage output, connect the positive analog out and negative analog out pins to a differential input voltmeter or an analog-to-digital (A/D) converter. Do not connect the negative side of the analog output to the negative side of the power supply input or to any other ground. Doing so will cause half of the power current to flow through this wire. Measurement errors in the output voltage may be seen due to the voltage drop from this current. The longer the cable, the worse the error will be. Do not connect the set point relay terminals to the analog output.

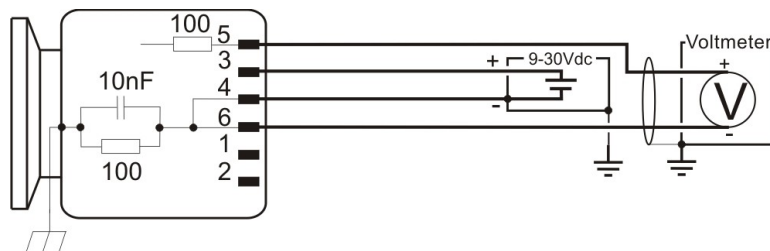

Correct connection of analog output to floating input

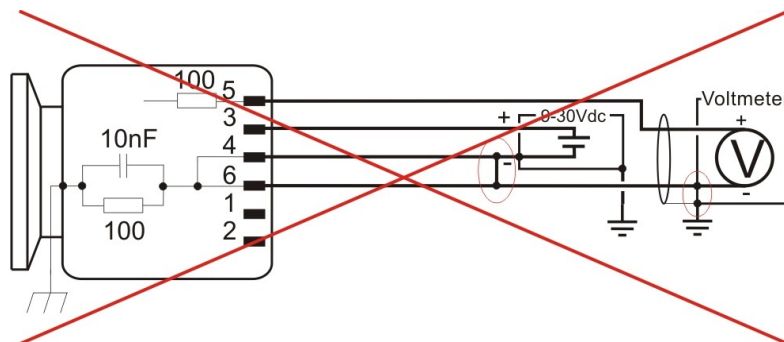

Incorrect connection of analog output to none floating input

High Voltage Control

The 971UniMag must be controlled externally to ensure that the high voltage is not enabled at pressures higher than 5×10^{-3} Torr. The protect setpoint feature prevents continuously operation at high pressures, however it should not be used as control function for the high voltage.

Refer to page 8 and 15 for control options.



Continuously operation over 5×10^{-3} Torr and fast pressure spikes with the high voltage enabled can damage the cold cathode sensor element or cause shift in calibration.

Input/Output Wiring

971 I/O Connector (15 pin)

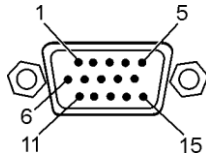

15 pin male HD DSUB

PIN	Description
1	RS485- / RS232 Transmit
2	RS485+ / RS232 Receive
3	Power + (9-30 VDC)
4	Power return -
5	Analog Output +
6	Analog Output -
7	Relay 1, Normally Open ⁽¹⁾
8	Relay 1, Common ⁽¹⁾
9	Relay 1, Normally Closed ⁽¹⁾
10	Relay 2, Normally Closed ⁽¹⁾
11	Relay 2, Common ⁽¹⁾
12	Relay 2, Normally Open ⁽¹⁾
13	Cold cathode enable (Active low)
14	Relay 3, Common ⁽¹⁾
15	Relay 3, Normally Open ⁽¹⁾

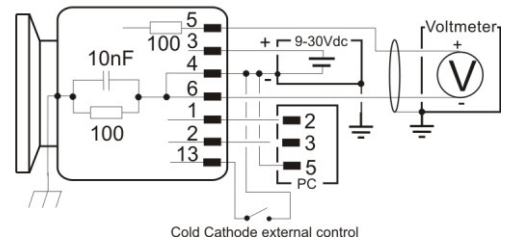

(1) Relays are optional (See part number page 3)



Cold cathode external control pin 13 must be floating or shortened to power supply ground pin 4. Do not connect to a voltage source. Connection to voltage source can cause permanent damage to the transducer.

971 I/O Connector P/N: 971-x1090-0001 (6 pin Hirschmann)



PIN	Description
1	Identification resistor (5.1KΩ)
2	Analog Output +
3	Analog Output -
4	Power + (9-30 VDC)
5	Power return -
6	Chassis

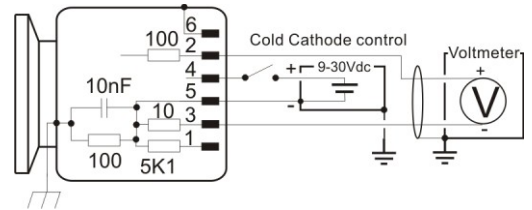

P/N: 971-x1090-0001, will always enable the high voltage when power is turned on. Power supply must be external controlled by switching power (pin 4) on and off to avoid continuously operation at high pressure.

971 I/O Connector P/N: 971-x1080-0002 P/N: 971-x1080-0003 (8 pin RJ45/FCC68)

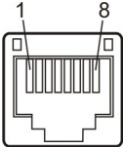

PIN	Description
1	Power + (9-30 VDC)
2	Power return -
3	Analog Output +
4	Identification resistor ⁽²⁾
5	Analog Output -
6	Set point output (Open collector)
7	Cold cathode enable (Active low)
8	Not Connected

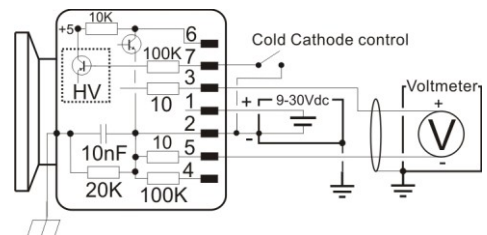

(2) Resistor value: 971-x1080-0002: 100K, 971-x1080-0003: 110K

971 RS232 connector (6 pin Hirschmann + 8 pin RJ45/FCC68)

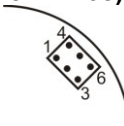

PIN	Description
1	RS232 Transmit
2	RS232 Ground
3	RS232 Receive
4	RS232 Receive
5	RS232 Ground
6	RS232 Transmit

Serial user interface

The 971 is as standard supplied with RS232 or RS485 user interface. The user interface allows change of transducer parameters such as set point settings and calibration.

The serial interface uses the following data format: 8 data bits, 1 stop bit and no parity bit.

RS232 user interface

The 971 is DCE (Data Communication Equipment) and can be connected to DTE (Data Terminal Equipment), typically a PC.

The serial communication does not use hardware handshake. The RS232 standard does not specify the maximum cable length, but length depends on environment, cable quality and communication speed. In general cable spans shorter than 15m (50ft.) do not require any extra precautions.

The RS232 connection on transducers delivered with 6 pin Hirschmann and 8 pin RJ45/FCC68 connector is available at a separate connector. Refer to Accessories and Replacement part number page 35 for RS232 programming cable. The connector is located under the label on the top of the transducer.

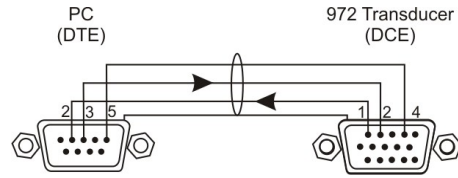

RS485 user interface

RS485 is a network communication system that enables the user to communicate with several units on the same communication line.

RS485 is a balanced communication system, because signal on one wire is ideally the exact opposite of the signal on the second wire. Compared to RS232 communication RS485 allows significantly longer cable span. The maximum length of cable span depends on the environment, cable quality and communication speed, but relative long cable spans up to 1,200m (4,000 ft.) is possible.

There are 2 wires other than ground that are used to transmit the digital RS485 signal. The 971 uses half duplex communication.

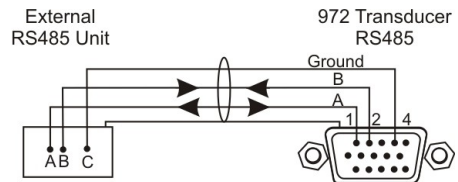

Always use high quality shielded data cables for serial communication. For long cable runs use twisted pairs. See also Accessory and Replacement part number page 35.

The EIA-485 and NMEA standards specification states that signal A is the inverting “-“and signal B is the non inverting or “+”. This is in conflict with the A/B naming used by a number of differential transceiver manufacturers which is incorrect, but their practice is used throughout the industry. Therefore care must be taken when using A/B naming. In addition to the A and B connections, the EIA standard also specifies a third interconnection point called C, which is the common ground.

At high communication baud rates and when using long cable runs, a termination resistor of typical 120 Ohm should be connected between pin 1 and 2 at the 971 DSUB connector and between pin A and B at the data communication equipment. The termination resistors provides low impedance that reduces the sensitivity to electrical noise and prevents data reflection that can cause data communication corruption.

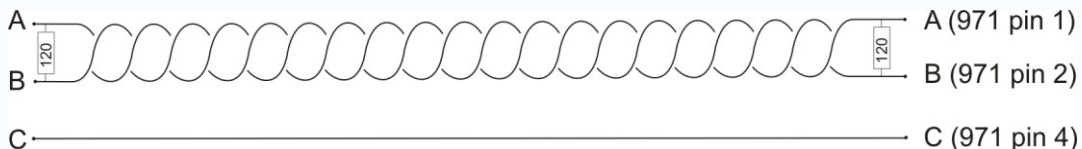

RS485 twisted pair cable run with 120 Ω terminator resistors (971 with 15 pin connector)



When connecting multiple devices in a RS485 network make sure that proper guidelines and specifications are followed to ensure optimal communication performance of the 971. Improper network design can cause data communication interruption and data collision.

Communication Protocol

The 971 transducer command set allows the user to change transducer parameters and receive pressure measurements. Settings and parameters like set point values, set point configurations and calibration data are stored in the transducers non volatile memory.

Communication software

Communication software is required to communicate from PC via RS232/485 interface to the transducer. In the standard Microsoft Windows package the hyper terminal software can be used to type and transmit serial commands to the transducer. To the right is illustrated the Windows communication port properties for communicating with transducer factory default settings. MKS also offers communication software examples that can be downloaded at: www.mksinst.com/vtsw/

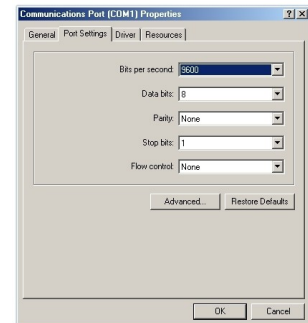

In OEM applications transducer communication software routines are normally integrated with other system control software.

Query and Command Syntax

Queries return current parameter settings; commands change the parameter setting according to the value the user enters into the command syntax. Each query or command must begin with the attention character @ and end with the termination ;FF.

Command syntax for an information query:

@<device address><query>;FF

Command syntax for a command:

@<device address><command>!<parameter>;FF

The command set allows upper and lower case ASCII characters.

Response Syntax (ACK/NAK)

The ASCII characters 'ACK' or 'NAK' preface the query or command response string. The ACK sequence signifies the message was processed successfully. The NAK sequence indicates there was an error.

The response to a query or a successful command is:

@<device address>ACK<data>;FF

The response to a message with an error is:

@<device address>NAK<NAK code>;FF

Examples:

ACK response: @253ACK9600;FF (baud rate changed to 9600)

NAK response: @253NAK160;FF (command had an error—possible typo)

The following list provides descriptions of the NAK codes that may be returned.

NAK Code	Error description	Example
8	Zero adjustment at too high pressure	@253VAC!;FF
9	Atmospheric adjustment at too low pressure	@253ATM!7.60;FF
160	Unrecognized message	@253S%;FF
169	Invalid argument	@253EN1!of;FF
172	Value out of range	@253SP1!5.00E+9;FF
175	Command/query character invalid	@253FV!;FF
180	Not in setup mode (locked)	-

Baud rate

The baud rate represents the communication speed. The 971 supports 4800, 9600, 19200, 38400, 57600, 115200 and 230400 baud rates. The transducer is always delivered with 9600 bps factory default baud rate.

Change of Baud rate:

Command:	@253BR!19200;FF
Command values:	4800, 9600, 19200, 38400, 57600, 115200, 230400
Command reply:	@253ACK19200;FF
Factory default:	9600

The transducer will reply in the current baud rate and then change to the new value.

Addressing

The transducer uses an addressable communication protocol that allows multiple MKS 900 Series transducer devices to be connected in a RS485 network. The address is required in both RS232 and RS485 communication.

The address can be set from 001 to 253. Address 254 and 255 are universal addresses, which can be used to broadcast a command to all devices on the network. Commands sent with address 254 will be executed by all transducers on the network and all transducers will transmit a reply. Commands sent with address 255 will be executed by all transducers on the network, but the transducers will not transmit replies. For example, use address 254 to communicate with a device if its address is unknown.

Change of Address:

Command:	@253AD!123;FF
Command values:	001 to 253
Command reply:	@253ACK123;FF
Query:	@254AD?;FF
Query reply:	@253ACK253;FF
Factory default:	253

Communication delay (RS485)

The 971 half duplex RS485 interface requires that data is transmitted and received on the same communication line. Some RS485 transceiver equipment have a settling time when changing from transmit to receive mode. If the transducer replies too fast the first character(s) will not be received as the following example illustrates:

Sending pressure request:	@254PR1?;FF
Receiving data: .	23E-4;FF (Correct data: @253ACK1.23E-4;FF)

The RS delay introduces a baud rate dependent delay between receive and transmit sequence to prevent loss of data in the receiving string.

Communication delay:

Command:	@253RSD!ON;FF
Command values:	ON, OFF
Command reply:	@253ACKON;FF
Query:	@253RSD?;FF
Query reply:	@253ACKON;FF
Factory default:	ON

Setpoint relays

The 971 can be ordered with 3 mechanical relays that can be used for controlling external process equipment. The relay has closing and breaking contacts and the contacts are rated 30 VDC, 1A resistive load.

If the transducer is supplied without setpoint relays, the setpoint commands can still be accessed. Refer to part number definition page 3 to verify if setpoint relays are included.

Inductive relay load

Special precautions should be taken when driving inductive loads at the relay contact. When an inductive load like a solenoid is energized, the in-rush current is significant higher than the regular load current. In-rush currents exceeding the relay contact rating can cause reduction of relay contact life time or contact reliability. When a solenoid is de-energized, the collapsing magnetic field can cause significant voltage spikes. These spikes can couple capacitive from cable to cable and interfere with measuring electronics or transducer signal.



Driving inductive loads via the setpoint relay contacts requires de-energizing spike protection. Inadequate protection can cause permanent damage to the transducer or interfere with the analog output signal. Always ensure that inductive inrush currents do not exceed relay contact rating.

An arc suppression network as shown schematically to the right is recommended. The values of the capacitance C and the resistance R can be calculated by the following equations:

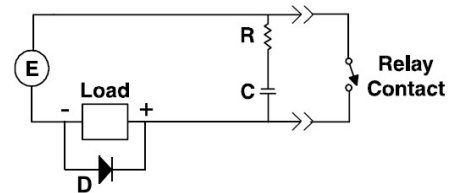

$$C = I^2 / (1 \times 10^7) \quad R = E / I^a$$

where:

C is in Farad. R is in Ohm

I is DC or AC_{peak} load current in Ampere. E is DC or AC_{peak} source voltage in Volt

a = 1 + (50/E)

Note that $R_{min} = 0.5 \Omega$ and $C_{min} = 1 \times 10^{-9} \text{ F}$. D is a fast transient suppression diode.

PDR900 controller relays

The PDR900 controller has power relays that can drive higher current loads and voltages than the transducer relays. If the transducer is used with the PDR900 controller refer to PDR900 manual for setup of relay output.



Do not connect any external sources to the transducer relay pins when using it together with the PDR900 controller. Always use the PDR900 relay outputs.

Setpoint functionality

The set point relays can be activated either above or below the set point values. The graphs below show the different relays stages in either below or above configuration. The NC contact will always be closed in case of power failure.

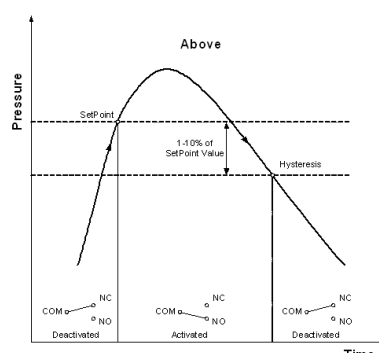
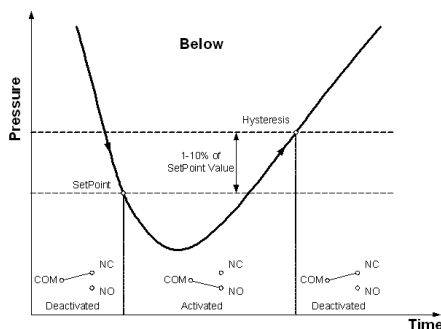



When using the setpoint relay to control process equipment, always take appropriate precautions to prevent system damage in case of transducer power failure. The NC contact will be closed in case of transducer power failure.



If the transducer is supplied as a special version (P/N: 971-xxxx-xxxx) with pre-configured parameters such as setpoint settings, the setup is per default locked. The transducer will reply with error code "NAK180" if the user tries to change parameters. To change pre-configured parameters refer to unlock procedure page 19.

Setpoint setup by Serial interface

The correct procedure for setting up set point parameters are:

1. Enter set point value 5.00E-6 Torr
Command: @253SP1!5.00E-6;FF
Reply: @253ACK5.00E-6;FF
2. Select setpoint direction (ABOVE/BELOW)
Command: @253SD1!BELOW;FF
Reply: @253ACKBELOW;FF
3. Enter setpoint hysteresis value, if other than default +/- 10% of set point value is required.
Command: @253SH1!6.00E-6;FF
Reply: @253ACK6.00E-6;FF
4. Enable setpoint (OFF, ON)
Command: @253EN1!ON;FF
Reply: @253ACKON;FF

Setpoint setup by PDR900 Controller

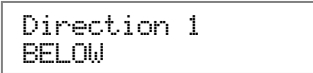
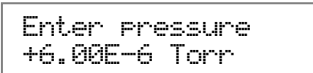
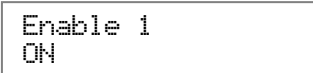
1. Edit > Setpoint > Setpoint 1> Setpoint Value 1
Enter set point value 5.00E-6 Torr

2. Edit > Setpoint > Setpoint 1> Direction 1
Select set point direction

3. Edit > Setpoint > Setpoint 1> Hysteresis 1
Enter set point hysteresis value
Only if other than default +/- 10% of set point value is required.

4. Edit > Setpoint > Setpoint 1> Enable 1
Enable set point

Setpoint value

The setpoint value is the pressure either below or above which the setpoint relay will be energized.

Setpoint hysteresis value

The hysteresis value is the pressure value at which the setpoint relay will be de-energized.

Setpoint direction

The setpoint direction determines whether the relay is energized above or below the set point value.

Enable setpoint

The enable setpoint command enables, disables or enable the setpoint relay.



The 971 transducer has an auto hysteresis setting of 10% of the set point value that overwrites the current hysteresis value whenever the set point value or set point direction is changed. If other hysteresis value than 10% is required, first set the set point value and set point direction before setting hysteresis value.

Setpoint safety delay

The setpoint safety delay function requires 5 continuously measurements that exceeds setpoint value before the relay is tripped. This feature prevents that noise or pressure pulse can trig the relay. If fast setpoint response is required the setpoint safety delay can be disabled.

Setpoint safety delay

Command: @253SPD!ON;FF
 Command values: ON, OFF

Command reply: @253ACKON;FF
 Query: @253SPD?;FF
 Query reply: @253ACKON;FF
 Factory default: ON

Display

The 971 with integrated display provides real time pressure readout, pressure trend and setpoint status. The display setup can be changed via the intuitive menu interface. The settings menu views transducer settings.

Use the [▲] and [▼] keys to scroll the cursor and select menu point by pressing the [+] key.

Unit: Select pressure unit Torr, mbar or Pascal. (Will not change transducer unit setup)
 Orientation: Select display orientation
 Settings: View transducer parameters



Main menu



Unit selection

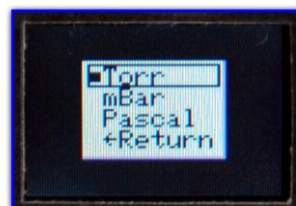

View Settings

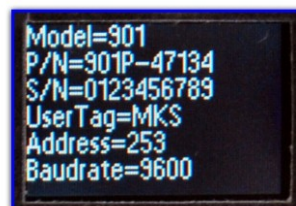

Cold cathode sensor control

The cold cathode sensor must be turned on before the transducer can provide pressure measurement values. The 971 can be controlled via digital interface, external analog control or manually.



P/N: 971-x1090-0001, will always enable the high voltage when power is turned on. Power supply must be external controlled by switching power (pin 4) on and off to avoid continuously operation at high pressure.

Digital Control of Cold cathode

Turn on Cold Cathode high voltage:

Command: @253FP!ON;FF
Command values: ON, OFF, ALWAYSON
Command reply: @253ACKON;FF

Query: @253FP?;FF
Query reply: @253ACKOFF;FF
Factory default: OFF

If FP is set to "ALWAYSON" the Cold Cathode high voltage will be turned on immediately when the transducer is powered on. Use power supply to control the transducer and prevent operation at higher pressure.

Analog Control of Cold cathode

The cold cathode can be controlled by external equipment by shorting pin 13 to power supply ground pin 4. The analog controller can either be momentarily pulse triggered or low level triggered.

Analog Level trig (factory default)

When enabling level trig the cold cathode sensor will be on when pin 13 is shorten to ground pin 4 and turned off when pin 13 is floating.

Enabling level trig:

Command: @253SW!OFF;FF
Command reply: @253ACKOFF;FF

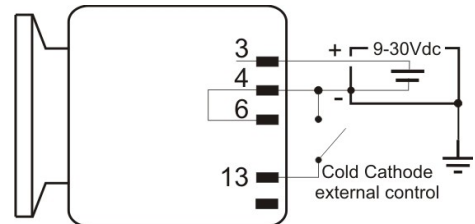

Analog Pulse trig

When enabling pulse trig the cold cathode sensor will be turn on when cold cathode enable (pin 13) is shorten momentarily to ground (pin 4) and turned off when cold cathode enable (pin 13) is shorten momentarily to ground (pin 4) again.

Enabling pulse trig:

Command: @253SW!ON;FF
Command reply: @253ACKON;FF

Query: @253SW?;FF
Query reply: @253ACKON;FF
Factory default: OFF



Cold cathode external control pin 13 must be floating or shorten to power supply ground pin 4. Do not connect to a voltage source. Connection to voltage source can cause permanent damage to the transducer.

Manual Control of Cold cathode

The cold cathode can also be controller by pressing the user switch. The Cold Cathode can either be activated or deactivated by pressing the switch momentarily (SW!ON) or activated while pressing down the switch (SW!OFF). The 971 is per factory default delivered with SW turned off.



Pressure output

The 971 transducer can provide pressure measurement output as an analog voltage or RS232/RS485 digital value. The digital value is 3 digits scientific notation for PR1, PR3, PR5 reading and 4 digits for PR4 reading.

Pressure request:

Query: @253PR1?;FF
Query reply: @253ACK1.23E-4;FF

Pressure outputs:

PR1: Cold Cathode reading
PR2: Cold Cathode reading
PR3: Cold Cathode reading
PR5: Cold Cathode reading

The default analog output is based on the combined PR1 reading and provides a 16 bit voltage output of 0.5 VDC/decade standard configuration. Refer to Analog output page 21 for details.



If ionization do not ignite or if the cold cathode reading is lower than the cold cathode zero value, the digital output provides: 1.00E-8 Torr



When designing external pressure control loops, make sure that external equipment like pumping system is not damaged if the transducer output enters Sensor defect mode page 15 or in case of power failure.



When designing pressure data collecting software and controlling loop, make sure that the software does not interpret a communication error as a valid pressure value.

Resolution

The digital pressure output can provide 3 digit or 4 digit values; however, the resolution is limited in certain parts of the measuring range.

1.00E-7 to 1.00E-8 Torr	2 digits resolution	1.50E-8
5.00E-3 to 1.00E-7 Torr	3 digits resolution	1.230E-4

Measuring noise

External sources can interfere with the sensor signal and cause noise in the signal. The low measuring range is most sensitive to measuring noise due to low signal levels.

Magnetic interference

External magnetic sources can interfere with the Cold Cathode sensor and cause measurement deviation from actual pressure. Avoid having magnetic material located close to the 971 Transducer.

Cold Cathode ignition startup

When the Cold Cathode high voltage is enabled an ignition delay may occur. The ignition waiting time is from less than a second at high pressures to minutes at low pressures. The ignition time is a function of gas density and cleanness of the gauge.

The combined analog output and PR3, PR4 reading provides the MicroPirani reading until ignition has occurred and valid Cold Cathode measurements is present. When the Cold Cathode is enabled, but ionization not ignited the LED will flash red. The LED will flash green when valid measurements are present.

Pressure	Typical ignition time
1.00E-8 Torr	≈12 Minutes
1.00E-6 Torr	≈10 Seconds
1.00E-4 Torr	≈1 Second

Cold Cathode protect setpoint

The Cold Cathode protect setpoint automatically turns off the Cold Cathode high voltage if the cold cathode measurement exceeds 5.00E-3 Torr for 120 seconds. The protect setpoint can be turned off (disabled) or time set between 0 and 999 seconds.

Command: @253PRO!ON;FF
Command values: ON (120), OFF, 0 to 999 seconds

Command reply: @253ACK120;FF
Query: @253PRO?;FF
Query reply: @253ACK120;FF
Factory default: OFF



If FP is set to "ALWAYSON" the protect setpoint is automatically disabled. (See page 15)

Calibration and adjustment

The 971 is factory calibrated when delivered and in many applications further calibration is not required. If the sensor element has been contaminated or damaged by process gases, adjustment of zero and full scale can be executed to compensate for small measurement errors.

Pressure unit calibration

The transducer can provide digital and analog output in torr, mbar and Pascal pressure units. When changing pressure unit all parameters such as setpoint settings are automatically converted to the new unit, so it will represent the same pressure level. All pressure parameters such as setpoint settings and calibration values must be entered in the actual transducer unit setting.

Change of pressure unit calibration setup:

Command: @253UIPASCAL;FF
Command values: TORR, MBAR, PASCAL

Command reply: @253ACKPASCAL;FF
Query: @253U?;FF
Query reply: @253ACKTORR;FF
Factory default: TORR

The torr unit is most common in the US and mbar is most common in Europe. Pascal is the official pressure unit as specified by SI (from the French *Le Système International d'Unités*) and is widely used in Asia.

Factory default

The transducer is per factory default delivered with parameters and setup as listed below. If the transducer is delivered with customer preconfigured parameters the values are different than listed below and the parameters will be locked per default.

Communication parameters:

Description	Command	Parameter	FD!	FD!ALL
Address:	AD!	253	-	x
Baud rate:	BR!	9600	-	x
Communication delay:	RSD!	ON	-	x

Transducer parameters:

Description	Command	Parameter	FD!	FD!ALL
Test mode (LED flash):	TST!	OFF	x	x
User tag:	UT!	MKS	-	x
Set point 1 value:	SP1!	1.00E0	-	x
Set point 1 hysteresis value:	SH1!	1.10E0	-	x
Set point 1 direction:	SD1!	BELOW	-	x
Set point 1 enable:	EN1!	OFF	-	x
Set point 2 value:	SP1!	1.00E0	-	x
Set point 2 hysteresis value:	SH1!	1.10E0	-	x
Set point 2 direction:	SD1!	BELOW	-	x
Set point 2 enable:	EN1!	OFF	-	x
Set point 3 value:	SP1!	1.00E0	-	x
Set point 3 hysteresis value:	SH1!	1.10E0	-	x
Set point 3 direction:	SD1!	BELOW	-	x
Set point 3 enable:	EN1!	OFF	-	x
Setpoint safety delay:	SPD!	ON	-	x
Cold Cathode protect setpoint	PRO!	OFF		
-	x			
Switch enable:	SW!	OFF	-	x
Analog out 1:	AO1!	30 ⁽¹⁾	-	x

(1) If the transducer is delivered with other analog output than standard mks (part number specified), then the factory default value will be specified by the specials part number.

Calibration setup:

Description	Command	Parameter	FD!	FD!ALL
Gas calibration:	GT!	NITROGEN	x	x
CC Vacuum adjustment:	VAC3!	<i>Factory adjustment value</i>	x	x
Pressure unit:	U!	TORR	-	x

Resetting to factory default

The factory default command resets all or certain parameters of the 971 to factory default settings as listed above. If other digital communication setup than factory default values are used, then the communication will be lost after execution of factory default and the transceiver equipment should be set to transducer values.



The factory default command resets parameters to default values and consequently user adjustments, setup and factory configured parameters are lost. Use with caution!

Command: @253FD!ALL;FF
 Command values: None, ALL, UNLOCK, LOCK, VAC3
 Command reply: @253ACKFD;FF

Transducer lock function

To ensure that no unauthorized personal are able to change transducer setup and parameters, the transducer lock function can prevent direct access to parameter changes. Transducers delivered with pre-configured custom specified parameters (special part number) are per default locked and will reply with "NAK180", if the user tries to change locked parameters. The unlock procedure must be executed to change these parameters.

Disable lock function command:

Command: @253FD!UNLOCK;FF
Command reply: @253ACKFD;FF

Enable lock function command:

Command: @253FD!LOCK;FF
Command reply: @253ACKFD;FF

Standard transducer (7 digits part number: 971-xxxx)
Factory default: *Transducer unlocked*

Special configuration transducer (11 digits part number: 971-xxxx-xxxx)
Factory default: *Transducer locked*



If the transducer is delivered with special configuration, the lock function will only be temporarily disabled and will be enabled again after cycling power cycle or executing the enable lock command.



The 971 transducer can be delivered with factory locked tamperproof settings for safety interlock applications. This option is defined in the special settings. If delivered with factory lock the transducer settings can only be changed by return of gauge to MKS.

User Switch Command

The User Switch command defines if the Cold Cathode sensor voltage is turned on by level trig or pulse trig. For details see Cold Cathode sensor control.

Command: @253SW!OFF;FF
Command values: ON,OFF

Command reply: @253ACKOFF;FF
Query: @253SW?;FF
Query reply: @253ACKON;FF
Factory default: OFF

Transducer test

The transducer test command can be used to visually identify a transducer. If the test mode is enabled the LED will flash with a 1 sec. cycle.

Command: @253TST!ON;FF
Command values: ON,OFF

Command reply: @253ACKON;FF
Query: @253TST?;FF
Query reply: @253ACKON;FF
Factory default: OFF

Status Query Commands

Device Type - DT

Specifies transducer device type name:

Query: @253DT?;FF
Query reply: @253ACKUNIMAG;FF

Firmware Version - FV

Specifies transducer firmware version:

Query: @253FV?;FF
Query reply: @253ACK1.12;FF

Hardware Version - HV

Specifies transducer hardware version:

Query: @253HV?;FF
Query reply: @253ACKA;FF

Manufacturer - MF

Specifies transducer manufacturer:

Query: @253MF?;FF
Query reply: @253ACKMKS;FF

Model - MD

Specifies transducer model number:

Query: @253MD?;FF
Query reply: @253ACK971;FF

Part Number - PN

Specifies transducer part number:

Query: @253PN?;FF
Query reply: @253ACK971-11030;FF

Serial Number - SN

Specifies transducer serial number:

Query: @253SN?;FF
Query reply: @253ACK0825123456;FF

Time ON - TIM

The TIM command returns the number of hours the transducer has been on:

Query: @253TIM?;FF
Query reply: @253ACK123;FF

Time ON (Cold Cathode sensor) – TIM2

The TIM2 command returns the number of hours the cold cathode high voltage has been on:

Query: @253TIM2?;FF
Query reply: @253ACK123;FF

Transducer Status – T

The T command returns the Transducer sensor status as O for OK, C for Cold Cathode failure or G for Cold Cathode ON.

Query: @253T?;FF
Query reply: @253ACKO;FF

Analog output

The 971 transducer provides a voltage output as function of pressure.

The standard output is 0.5 VDC/decade but can also be configured to emulate other analog outputs.

Analog output calibration = 0 (MKS standard 0.5 VDC/decade)

$$P_{\text{Torr}} = 10^{(2 \times V_{\text{out}} - 11)}$$

$$V_{\text{out}} = \frac{\log(P_{\text{Torr}}) + 11}{2}$$

$$P_{\text{mbar}} = 10^{((2 \times V_{\text{out}} - 11))}$$

$$V_{\text{out}} = \frac{\log(P_{\text{mbar}}) + 11}{2}$$

$$P_{\text{Pascal}} = 10^{((2 \times V_{\text{out}} - 6))}$$

$$V_{\text{out}} = \frac{\log(P_{\text{Pascal}}) + 6}{2}$$

The standard MKS analog output always provides 0.5 VDC/decade. If the transducer pressure unit is changed from Torr to Pascal or mbar the analog output scaling will change as well, so it represents 0.5 VDC/decade Torr or 0.5 VDC/decade mbar or Pascal.

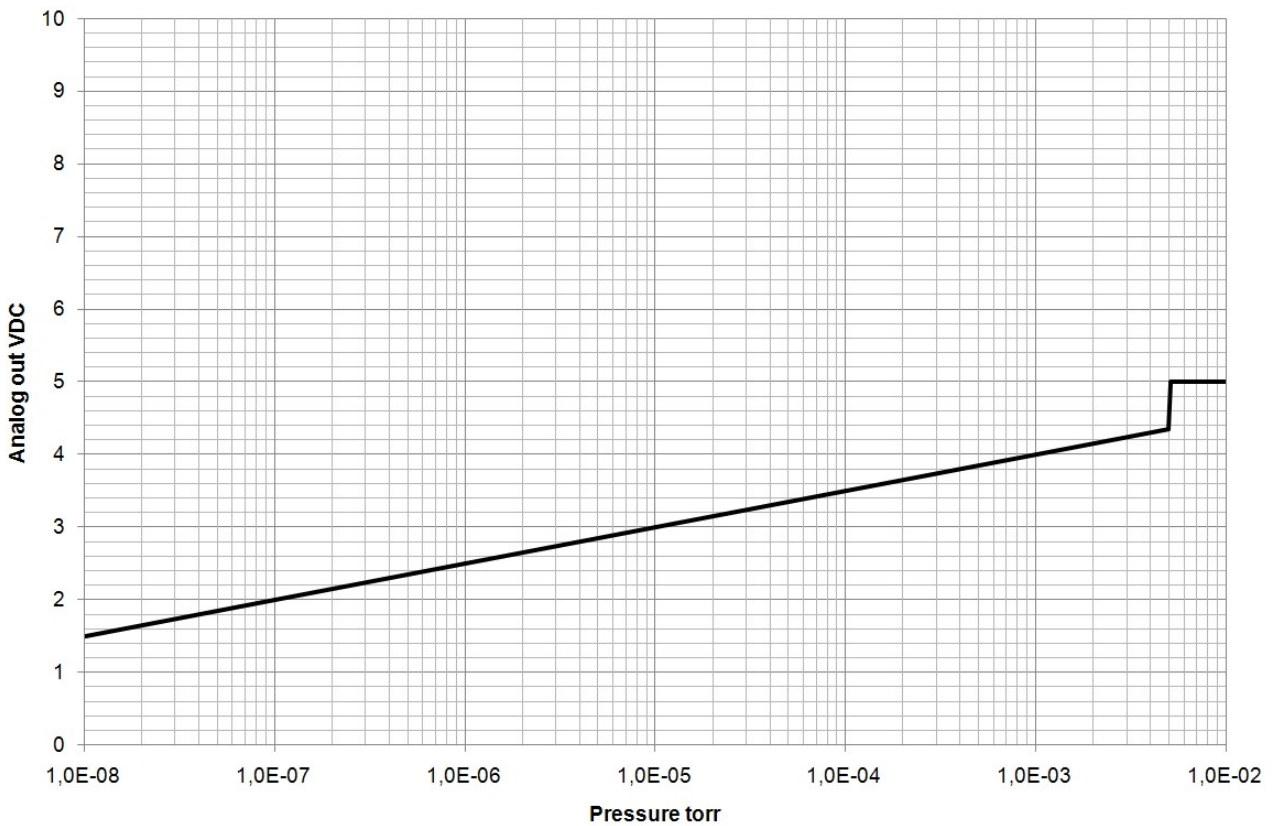

Torr/mbar	Vout	Torr/mbar	Vout
1.0E-8	1.5000	1.0E-5	3.0000
2.0E-8	1.6505	2.0E-5	3.1505
4.0E-8	1.8010	4.0E-5	3.3010
6.0E-8	1.8891	6.0E-5	3.3891
8.0E-8	1.9515	8.0E-5	3.4515
1.0E-7	2.0000	1.0E-4	3.5000
2.0E-7	2.1505	2.0E-4	3.6505
4.0E-7	2.3010	4.0E-4	3.8010
6.0E-7	2.3891	6.0E-4	3.8891
8.0E-7	2.4515	8.0E-4	3.9515
1.0E-6	2.5000	1.0E-3	4.0000
2.0E-6	2.6505	2.0E-3	4.1505
4.0E-6	2.8010	4.0E-3	4.3010
6.0E-6	2.8891	5.0E-3	4.3494
8.0E-6	2.9515	OFF	5.0000

Analog output setup

The 971 can emulate analog voltage outputs from other vacuum transducers. The 971 analog output can be assigned to the MicroPirani sensor measurement (PR1), Cold Cathode sensor measurement (PR2, PR5) and the combined Cold cathode / MicroPirani reading (PR3). This is set by the first digit. The second and third digit represents the analog output calibration.

The primary analog output provides 16 bit resolution.



Due to curve form and limits, some of the alternative analog outputs will cause loss of measuring range and accuracy. For best performance use the standard MKS analog output. Change of analog output setup does not interfere on digital reading.

Change of analog output setup:

Command:	@253AO1!15;FF
Command values:	10 to 319 (xy)
First digit (x)	1 = PR1 (Cold cathode pressure value assignment)
Second digit (y)	0 = MKS Standard (0.5 VDC/decade) 1 = Edwards APG-L (1.99 -10 VDC) 2 = Edwards APG100 3 = Edwards WRG 4 = Inficon PSG500 /Oerlikon/Leybold TTR91 5 = Inficon MPG400 / Pfeiffer PKR251 6 = Inficon BPG400 / MKS 999 Quattro 7 = Brooks / Granville Phillips GP275 8 = MKS Moducell 325 9 = MKS Moducell 325 (x3) 10 = MKS Baratron 0.1 Torr (0-10 VDC) 11 = MKS Baratron 1 Torr (0-10 VDC) / Hasting 2002OBE, Channel 2 12 = MKS Baratron 10 Torr (0-10 VDC) 13 = MKS Baratron 100 Torr (0-10 VDC) 14 = MKS Baratron 1000 Torr (0-10 VDC) / Hasting 2002OBE, Channel 1 15 = Piezo differential output 16 = Edwards AIM-S /-SL 17 = Edwards AIM-X / XL 18 = Pfeiffer IKR251 19 = Pfeiffer TPR 265 20 = OBE Channel 2 21 = Edwards DV6M 22 = Edwards APG-M
Command reply:	@253ACK15;FF
Query:	@253AO1?;FF
Query reply:	@253ACK105;FF
Factory default:	30

Analog output calibration = 3 (Edward WRG emulation)

The WRG emulation covers a wider measuring range than supported by the 971 range.

$$P_{\text{Torr}} = 10^{(1.5 \times V_{\text{out}} - 12.125)}$$

$$P_{\text{mbar}} = 10^{(1.5 \times V_{\text{out}} - 12)}$$

$$P_{\text{Pascal}} = 10^{(1.5 \times V_{\text{out}} - 10)}$$

$$V_{\text{out}} = (\log_{10}(P_{\text{Torr}}) + 12.125) / 1.5$$

$$V_{\text{out}} = (\log_{10}(P_{\text{mbar}}) + 12) / 1.5$$

$$V_{\text{out}} = (\log_{10}(P_{\text{Pascal}}) + 10) / 1.5$$

Torr	mbar	Pascal	Vout
1.00E-8	1.33E-8	1.33E-6	2.75
2.37E-8	3.16E-8	3.16E-6	3.00
7.50E-7	1.00E-6	1.00E-4	4.00
2.37E-5	3.16E-5	3.16E-2	5.00
7.50E-4	1.00E-3	1.00E-1	6.00
2.37E-2	3.16E-2	3.16	7.00
7.50E-1	1.00	100	8.00
2.37	31.6	3.160	9.00
750.0	1.000	100.000	10.00

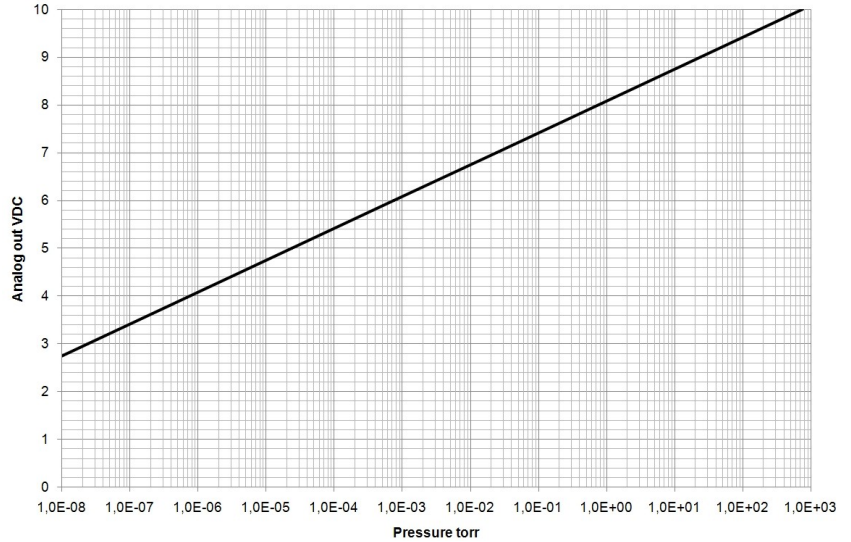

Analog output calibration = 5 (Inficon MPG400 / Pfeiffer PKR251 emulation)

$$P_{\text{Torr}} = 10^{((V_{\text{out}} - 11.46) \times 1.667)}$$

$$P_{\text{mbar}} = 10^{((V_{\text{out}} - 11.33) \times 1.667)}$$

$$P_{\text{Pascal}} = 10^{((V_{\text{out}} - 9.33) \times 1.667)}$$

$$V_{\text{out}} = \log_{10}(P_{\text{Torr}}) \times 0.6 + 6.875$$

$$V_{\text{out}} = \log_{10}(P_{\text{mbar}}) \times 0.6 + 6.8$$

$$V_{\text{out}} = \log_{10}(P_{\text{Pascal}}) \times 0.6 + 5.6$$

Torr	mbar	Pascal	Vout
1.00E-8	1.33E-8	1.33E-6	2.075
1.00E-7	1.33E-7	1.33E-5	2.675
1.00E-6	1.33E-6	1.33E-4	3.275
1.00E-5	1.33E-5	1.33E-3	3.875
1.00E-4	1.33E-4	1.33E-2	4.475
1.00E-3	1.33E-3	1.33E-1	5.075
1.00E-2	1.33E-2	1.33E+0	5.675
1.00E-1	1.33E-1	1.33E+1	6.275
1.00E+0	1.33E+0	1.33E+2	6.875
1.00E+1	1.33E+1	1.33E+3	7.475
1.00E+2	1.33E+2	1.33E+4	8.075
7.60E+2	1.01E+3	1.01E+5	8.603

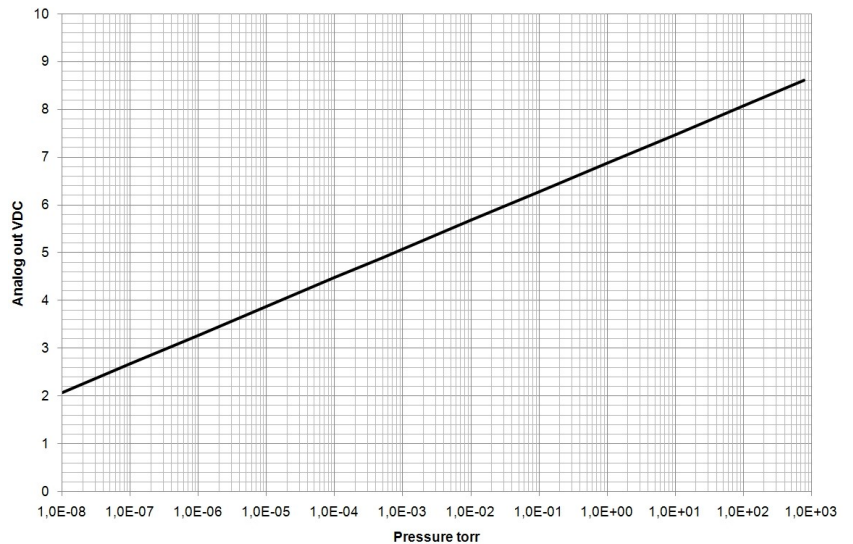

Analog output calibration = 6 (Inficon BPG400 emulation)

$$P_{\text{Torr}} = 10^{((V_{\text{out}} - 7.75)/0.75) - 0.125}$$

$$P_{\text{mbar}} = 10^{((V_{\text{out}} - 7.75)/0.75)}$$

$$P_{\text{Pascal}} = 10^{((V_{\text{out}} - 7.75)/0.75) + 2}$$

$$V_{\text{out}} = \log_{10}(P_{\text{Torr}} + 0.125) \times 0.75 + 7.75$$

$$V_{\text{out}} = \log_{10}(P_{\text{mbar}}) \times 0.75$$

$$V_{\text{out}} = \log_{10}(P_{\text{Pascal}} - 2) \times 0.75$$

Torr	mbar	Pascal	Vout
1.00E-8	1.33E-8	1.33E-6	1.843
1.00E-7	1.33E-7	1.33E-5	2.593
1.00E-6	1.33E-6	1.33E-4	3.343
1.00E-5	1.33E-5	1.33E-3	4.093
1.00E-4	1.33E-4	1.33E-2	4.843
5.00E-4	6.67E-4	6.67E-2	5.367
1.00E-3	1.33E-3	1.33E-1	5.593
1.00E-2	1.33E-2	1.33E+0	6.343
1.00E-1	1.33E-1	1.33E+1	7.093
1.00E+0	1.33E+0	1.33E+2	7.843
1.00E+1	1.33E+1	1.33E+3	8.593
1.00E+2	1.33E+2	1.33E+4	9.343
7.60E+2	1.01E+3	1.01E+5	10.004

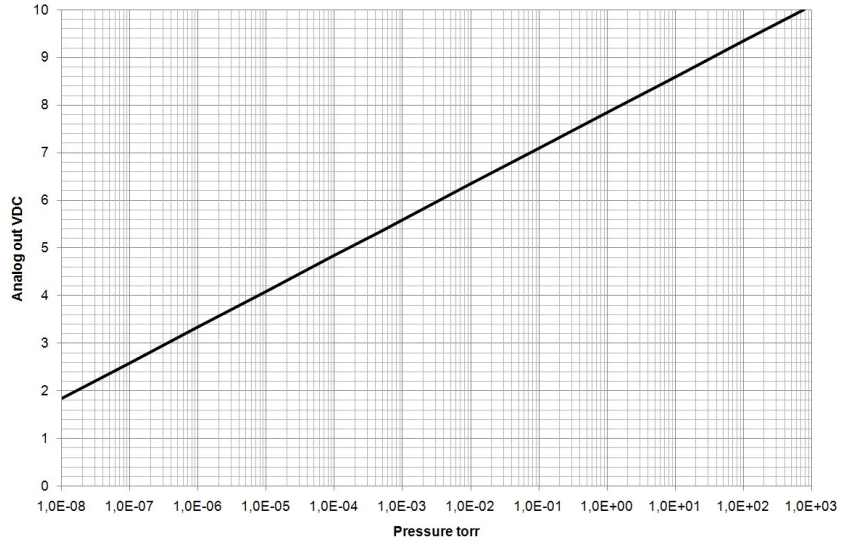

Analog out calibration = 16 (Edwards AIM-S /SL)

The Edwards AIM-S / SL emulation provides a strongly non linear output.

Torr	mbar	Pascal	Vout
1.00E-8	1.33E-8	1.33E-6	2.5
1.80E-8	2.40E-8	2.40E-6	2.5
4.40E-8	5.87E-8	5.87E-6	3
6.10E-8	8.13E-8	8.13E-6	3.2
8.30E-8	1.11E-7	1.11E-5	3.4
1.10E-7	1.47E-7	1.47E-5	3.6
2.20E-7	2.93E-7	2.93E-5	4
5.50E-7	7.33E-7	7.33E-5	4.6
7.40E-7	9.87E-7	9.87E-5	4.8
9.80E-7	1.31E-6	1.31E-4	5
1.30E-6	1.73E-6	1.73E-4	5.2
2.10E-6	2.80E-6	2.80E-4	5.6
3.40E-6	4.53E-6	4.53E-4	6
4.20E-6	5.60E-6	5.60E-4	6.2
5.20E-6	6.93E-6	6.93E-4	6.4
7.50E-6	1.00E-5	1.00E-3	6.8
9.00E-6	1.20E-5	1.20E-3	7
1.10E-5	1.47E-5	1.47E-3	7.2
2.20E-5	2.93E-5	2.93E-3	8
3.20E-5	4.27E-5	4.27E-3	8.4
4.30E-5	5.73E-5	5.73E-3	8.6
5.90E-5	7.87E-5	7.87E-3	8.8
9.00E-5	1.20E-4	1.20E-2	9
1.40E-4	1.87E-4	1.87E-2	9.2
2.5E-4	3.33E-4	3.33E-2	9.4
5.0E-4	6.67E-4	6.67E-2	9.6
1.3E-3	1.73E-3	1.73E-1	9.8
2.7E-3	3.60E-3	3.60E-1	9.9
7.5E-3	1.00E-2	1.00E+1	10

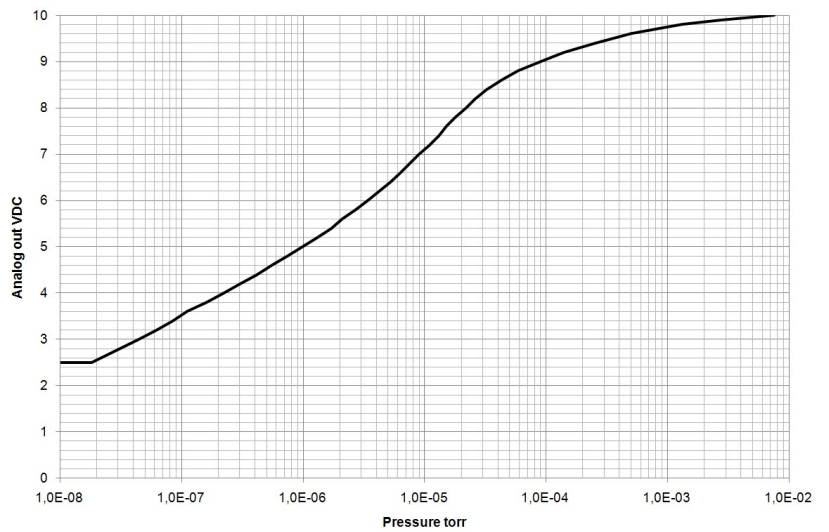

Cold cathode off, Vout = 1.5 VDC

Analog out calibration = 17 (Edwards AIM-X /XL)

The Edwards AIM-X / XL emulation provides a log linear output.

Torr	mbar	Pascal	Vout
1.00E-8	1.33E-8	1.33E-6	3.286
5.00E-8	6.67E-8	6.67E-6	4.084
1.00E-7	1.33E-7	1.33E-5	4.428
5.00E-7	6.67E-7	6.67E-5	5.227
1.00E-6	1.33E-6	1.33E-4	5.571
5.00E-6	6.67E-6	6.67E-4	6.370
1.00E-5	1.33E-5	1.33E-3	6.714
5.00E-5	6.67E-5	6.67E-3	7.513
1.00E-4	1.33E-4	1.33E-2	7.857
5.00E-4	6.67E-4	6.67E-2	8.656
1.00E-3	1.33E-3	1.33E-1	9.000
5.00E-3	6.67E-3	6.67E-1	9.799

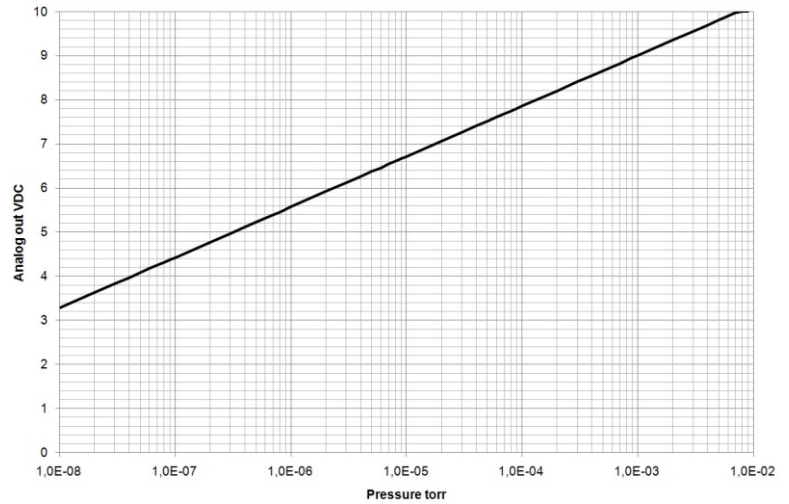

Analog out calibration = 18 (Pfeiffer IKR251)

The Pfeiffer AIM-X / XL emulation provides a log linear output.

Torr	mbar	Pascal	Vout
5.00E-9	6.67E-9	6.67E-7	2.3240
1.00E-8	1.33E-8	1.33E-6	2.6250
5.00E-8	6.67E-8	6.67E-6	3.3240
1.00E-7	1.33E-7	1.33E-5	3.6250
5.00E-7	6.67E-7	6.67E-5	4.3240
1.00E-6	1.33E-6	1.33E-4	4.6250
5.00E-6	6.67E-6	6.67E-4	5.3240
1.00E-5	1.33E-5	1.33E-3	5.6250
5.00E-5	6.67E-5	6.67E-3	6.3240
1.00E-4	1.33E-4	1.33E-2	6.6250
5.00E-4	6.67E-4	6.67E-2	7.3240
1.00E-3	1.33E-3	1.33E-1	7.6250
5.00E-3	6.67E-3	6.67E-1	8.3240
9.00E-3	1.20E-2	1.20E+	8.5000

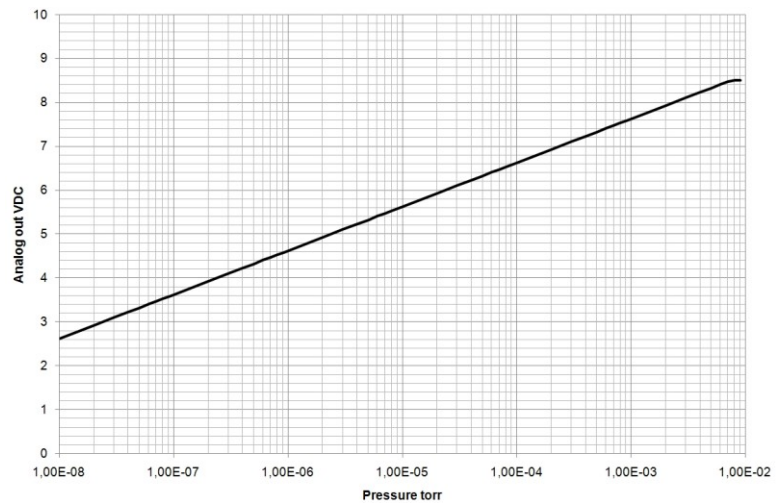

Query Command list

Communication information

Command	Response	Explanation
@xxxBR?;FF	@xxxACK9600;FF	Communication baud rate (4800, 9600, 19200, 38400, 57600, 115200,230400)
@xxxAD?;FF	@xxxACK253;FF	Transducer communication address (001 to 253)
@xxxRSD?;FF	@xxxACKON;FF	Communication delay between receive and transmit sequence.

Pressure reading

Command	Response	Explanation
@xxxPR1?;FF	@xxxACK1.23E-5;FF	MicroPirani sensor pressure as 3 digit floating point value.
@xxxPR2?;FF	@xxxACK1.23E-5;FF	Cold Cathode sensor pressure as 3 digit floating point value.
@xxxPR3?;FF	@xxxACK1.23E-5;FF	Combined Cold Cathode and MicroPirani pressure (3 digits).
@xxxPR4?;FF	@xxxACK1.234E-5;FF	Combined Cold Cathode and MicroPirani pressure (4 digits).
@xxxPR5?;FF	@xxxACK1.234E-5;FF	Cold Cathode sensor pressure as 3 digit floating point value.

Setpoint information

Command	Response	Explanation
@xxxSS1?;FF @xxxSS2?;FF @xxxSS3?;FF	@xxxACKSET;FF	Set point relay 1-3 status (SET=Relay energized / CLEAR=Relay deenergized)
@xxxSP1?;FF @xxxSP2?;FF @xxxSP3?;FF	@xxxACK1.00E-2;FF	Set point 1-3 switch value.
@xxxSH1?;FF @xxxSH2?;FF @xxxSH3?;FF	@xxxACK1.10E-2;FF	Set point 1-3 hystereses switch value.
@xxxEN1?;FF @xxxEN2?;FF @xxxEN3?;FF	@xxxACKOFF;FF	Set point 1-3 enable status (OFF, PIR=MicroPirani, or CC=Cold Cathode)
@xxxSD1?;FF @xxxSD2?;FF @xxxSD3?;FF	@xxxACKBELOW;FF	Set point relay direction (ABOVE or BELOW) If set to above relay will be energized above setpoint value. If set to below relay will be energized below setpoint value.

Transducer information

Command	Response	Explanation
@xxxMD?;FF	@xxxACK971;FF	Model number (971)
@xxxDT?;FF	@xxxACKUniMag;FF	Device type name (MicroPirani)
@xxxMF?;FF	@xxxACKMKS;FF	Manufacturer name (MKS)
@xxxHV?;FF	@xxxACKA;FF	Hardware version
@xxxFV?;FF	@xxxACK1.12;FF	Firmware version
@xxxSN?;FF	@xxxACK08350123456;FF	Serial number
@xxxSW?;FF	@xxxACKON;FF	Switch enable
@xxxTIM?;FF	@xxxACK123;FF	Time on (hours of operation)
@xxxTIM2?;FF	@xxxACK24;FF	High voltage time on (hours of operation with HV enabled)
@xxxUT?;FF	@xxxACKVACUUM1;FF	User programmed text string (user tag)
@xxxT?;FF	@xxxACKO;FF	Transducer status check

Calibration and adjustment information

Command	Response	Explanation
@xxxU?;FF	@xxxACKTORR;FF	Pressure unit setup (Torr, mbar or Pascal)
@xxxAO1?;FF	@xxxACK10;FF	Analog voltage output 1: Pressure assignment and calibration. (first digit is pressure assignment, second and third digit is calibration)

xxx = Transducer communication address (001 to 253. Broadcast addresses: 254, 255)

Setup and configuration command list

Setpoint setup and configuration

Command	Response	Explanation
@xxxSP1!2.00E+1;FF @xxxSP2!2.00E+1;FF @xxxSP3!2.00E+1;FF	@xxxACK2.00E+1;FF	Set point 1-3 switch value.
@xxxSH1!5.00E+1;FF @xxxSH2!5.00E+1;FF @xxxSH3!5.00E+1;FF	@xxxACK5.00E+1;FF	Set point 1-3 hysteresis switch value.
@xxxEN1!ON;FF @xxxEN2!ON;FF @xxxEN3!ON;FF	@xxxACKON;FF	Set point 1-3 enable status (ON or OFF)
@xxxSD1!BELOW;FF @xxxSD2!BELOW;FF @xxxSD3!BELOW;FF	@xxxACKBELOW;FF	Set point relay direction (ABOVE or BELOW) If set to above relay will be energized above setpoint value. If set to below relay will be energized below setpoint value.
@xxxSPD!ON;FF	@xxxACKON;FF	Setpoint safety delay (prevent pulse trig of setpoint)

Communication setup

Command	Response	Explanation
@xxxBR!19200;FF	@xxxACK19200;FF	Set communication Baud rate (4800, 9600, 19200, 38400, 57600, 115200, 230400)
@xxxAD!123;FF	@xxxACK123;FF	Set transducer communication address (001 to 253)
@xxxRSD!OFF;FF	@xxxACKOFF;FF	Turn on or off communication delay between receive and transmit sequence.

Calibration and adjustment

Command	Response	Explanation
@xxxU!MBAR;FF	@xxxACKMBAR;FF	Set pressure unit setup (Torr, mbar, Pascal)
@xxxVAC!;FF	@xxxACK;FF	Executes MicroPirani zero adjustment
@xxxATM!7.60E+2;FF	@xxxACK;FF	Executes MicroPirani full scale atmospheric adjustment.
@xxxVAC3!;FF	@xxxACK;FF	Executes Cold Cathode zero adjustment
@xxxAO1!10;FF	@xxxACK10;FF	Set analog voltage output 1 calibration.

Information setup

Command	Response	Explanation
@xxxUT!UNIMAG;FF	@xxxACKUNIMAG;FF	Set transducer user tag

User Switch

Command	Response	Explanation
@xxxSW!ON;FF	@xxxACKON;FF	Enable / disable user switch

xxx = Transducer communication address (001 to 253. Broadcast addresses: 254, 255)

FAQ (Frequently Asked Questions)

Applications

Q: *Can the transducer and sensor element continuously withstand vibrations from a mechanical fore-pump.*

A: Yes – the cold cathode sensor can withstand continuous vibrations.

Q: *When the transducer is pumped down and isolated by closing a valve the pressure is raising. Is the transducer leaking?*

A: Not likely - when a confined space is evacuated and the pumping is stopped the pressure will rise because of out gassing, mainly by water vapor. The pressure can easily rise to a few Torr over time.

Q: *When the transducer is leak checked on a helium leak detector, leak reading is building up slowly after approximately 30 seconds. Is the transducer leaking?*

A: No - the internal sealing of the 971 transducer uses elastomer viton sealing and consequently helium molecules can penetrate through the viton material and cause slow increase of helium leak readout. If a leaking transducer is tested directly on a helium leak detector the leak is almost instant displayed.

Q: *Can the transducer be mounted in any orientation?*

A: Yes - the transducer can be mounted in any orientation without compromise of performance or calibration. However it is recommended not to mount the transducer with the flange port facing upwards to avoid contamination like particulates or liquids from entering the device.

Q: *Can the transducer withstand instant ventilation?*

A: Yes – However, it's not recommended to perform instant ventilation when the Cold Cathode is turn on.

Q: *Can I connect a valve to be controlled by the transducer relay contact?*

A: Driving inductive loads such as valves requires special precautions. Refer to detailed description page 12.

Q: *How many pressure cycles can the transducer withstand?*

A: Cold Cathode sensor element is very mechanical robust to pressure changes and there are no limits on the number of pressure cycles. In applications where fast pressure cycles occur, the Cold Cathode sensor can be sputtered and this can lead to change of accuracy.

Q: *The Cold Cathode sensor chamber has changed color, Why?*

A: If the Cold Cathode is operated at high pressure ($>1.00E-4$ Torr) the cold cathode sensor module can be sputtered. This will change the color of the internal measuring chamber and can also result in change of measuring accuracy.

Analog output

Q: *What is the update rate of the analog output?*

A: 16 times per second.

Q: *What is the maximum length of analog output cable?*

A: The length of analog cable depends on cable quality and electrical noise environment, but cable length up to 100 m do not normally require any special precautions other than the cable must be screened.

Q: *The digital reading is correct but the analog output reading has some deviation from actual pressure?*

A: Check that the analog out is connected to a floating input and not an input that is connected to ground. If connected analog out return is connected to ground, the supply current will flow in the signal line and cause voltage drop and ground looping.

Digital output

Q: *How fast can I request pressure measurements via the digital interface?*

A: 10 times per second is the fastest recommended pressure request frequency.

Q: *How long is the waiting time from turning power on to valid measuring values?*

A: The power on sequence is approximately 2 seconds. The LED is illuminating red during power up sequence and the digital interface will not reply to commands. The ionization can take a few minutes to stabilize. If the cold cathode is turned on at low pressure $<1.00E-7$ Torr it can take several minutes before the ionization starts.

Q: *The first character is sometimes lost in the transducer digital communication reply?*

A: This can be caused by too fast transducer communication reply. See RS delay command description page 11.

Q: *Is it necessary to use the ground wire between RS485 communication equipment and transducer?*

A: Yes - both RS232 and RS485 communication requires a 3 wire connection between transducer and communication equipment.

Calibration and adjustment

Q: *How often does the transducer require calibration or Zero adjustment?*

A: Calibration of cold cathode sensor is normally not required. The reading in the low range can be user calibrated by use of the VAC3 command.

Q: *How long is the warm up time before obtaining reliable measurements from the transducer?*

A: Reliable measurements are typically available within 5 minutes.

Q: *Will the transducer retain user calibration after power is shut off?*

A: Yes - all transducer parameters including calibration data are stored internally in the transducer non volatile memory.

Service and repair

Q: *Can the sensor element be cleaned if contaminated?*

A: Yes – The cold cathode internal sensor chamber can be cleaned using solvents compatible with 304 stainless steel 403 stainless steel, Ceramic (Al₂O₃), Viton[®] and epoxy resin.

Q: *Can the sensor element be changed if contaminated?*

A: Yes - the cold cathode anode module can be changed or cleaned. Refer to Service and Repair page 31.

Q: *How often does the Cold Cathode sensor require cleaning?*

A: Contaminants such as oil vapors from oil lubricated for pump will cause carbonaceous deposits which will affect sensitivity of the gauge. The cleaning interval depends on contamination type and pressure range, but can be down to a few hundred of hours of Cold Cathode operation time. Cold Cathode time on can be read by using the command: @254TIM2?;FF

The anode module can be removed and mechanical polished or replaced.

Q: *+24 VDC supply voltage has been connected to analog output+. Is the transducer damaged?*

A: Likely - the analog output is not protected against applying power to the output pin.

Q: *Reverse voltage has been connected to power supply input. Is the transducer damaged?*

A: Not likely – the transducer power supply circuit has reverse voltage and over voltage protection however. MKS cannot guarantee that the transducer will not be damaged.

Q: *The status LED is constantly illuminating red?*

A: The red status indicates a defect sensor element. Refer to Service and Repair page 31.

Trouble shooting

Symptom	Possible Cause/Remedy
No digital communication	<ul style="list-style-type: none"> - Check electrical connections (3 wires from transducer to communication equipment) - Transducer and communication equipment baud rate matches - Use of incorrect transducer address. Try address 254 - Attention characters missing (@) - Termination characters missing (;FF)
NAK180 is received when transmitting setpoint commands	<ul style="list-style-type: none"> - The transducer setup is locked. Refer to disable lock procedure page 19
Incorrect pressure value	<ul style="list-style-type: none"> - Other gas present than transducer gas setting or trace of gas. - Contaminated sensor. Transducer repair required. - Corroded sensor. Transducer repair required.
Incorrect pressure value at low pressure.	<ul style="list-style-type: none"> - Contaminated sensor. Transducer repair required. - Corroded sensor. Transducer repair required. - Incorrect Vac adjustment has been executed.
Incorrect pressure value at high pressure.	<ul style="list-style-type: none"> - Contaminated sensor. Transducer repair required. - Other gas or gas trace present than transducer gas setting.
Cold Cathode does not provide measurements.	<ul style="list-style-type: none"> - If the Cold cathode is turned on a low pressure $<1.00E-7$ Torr or is contaminated a delay can occur from turning on high voltage to the ionization begins.
Cold Cathode value is lower than actual pressure.	<ul style="list-style-type: none"> - If the Cold Cathode sensor has been operated a too high pressure or exposed to fast pressure cycles the sensor can be sputtered. Sputtering of sensor will normally provide lower reading than actual pressure.
Set point relay does not trip.	<ul style="list-style-type: none"> - Setpoint not enabled. - Setpoint value not set to proper value. - Setpoint direction is different than the user expects. - Check electrical connection. - Check part number to see if transducer has setpoint relays.
No analog output	<ul style="list-style-type: none"> - Power supply turned off. - Check electrical connections.
Status LED illuminating red	<ul style="list-style-type: none"> - Sensor element defect. Refer to Service and Repair page 31.

Service and Repair

If a Cold Cathode sensor is turned on and operated at pressures higher than $1.0E-3$ Torr, material from the high voltage anode can be sputtered to the inside walls of the cold cathode transducer. Inert gases like argon are easier to ionize and consequently the sputter effect is more significant in such environment. If material is sputtered from the anode to the inside wall, of the transducer the pressure measurement will typically be lower than actual pressure. Sputtering can also be visually detected since the inside wall of the transducer changes color. When operated in oil lubricated pumping systems, hydrocarbons can cause contamination of cold cathode measuring cell. Contamination will normally cause a lower pressure reading than actual pressure. The cold cathode hour counter can be used to determine if service is required. If sputtering occurs, the anode module can be changed from the flanges side without disassembling of the transducer. The anode module (p/n: 970-ANODEKIT) is available as spare part. The basic accuracy of the cold cathode sensor can change after change of anode. The anode module can also be cleaned by mechanical polishing.

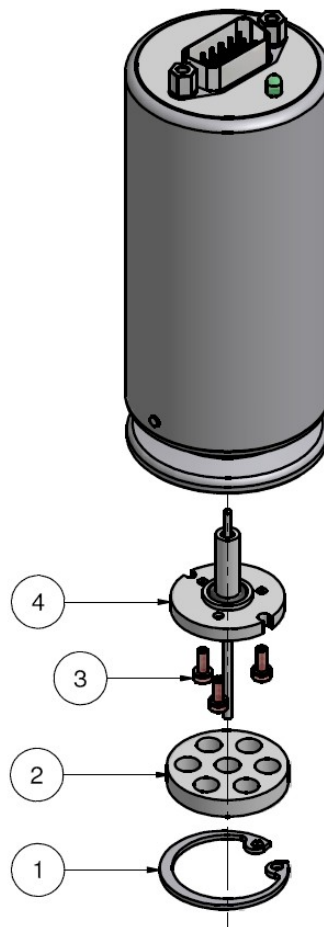
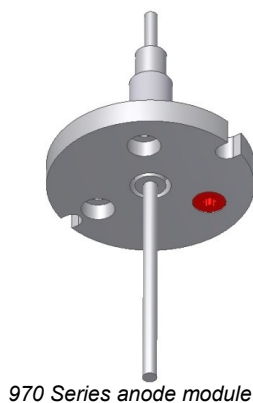

Do not touch anode module, screen, screws or clip ring by hand. If items are accidental touched by hand, use alcohol to clean items.

Changing the 971 anode module

1. Turn power off and remove cable.
2. Dismount the transducer from the vacuum system.
3. Remove the clip ring (1) using a clip ring remove/insert tool (p/n: 100017193).
4. Remove the screen (2).
5. Unscrew the three Torx (T6) screws (3) at the anode module (4).
6. Remove the anode module (4).
7. Insert the new anode module (Do not touch module).
8. Insert the screws (3), but DO NOT tighten. After all screws are inserted carefully tighten the screw a little and move on to the next one. Continue to tighten the screws one by one until all tight.
9. Insert the screen (2) and clip ring (1).
10. If a leak detector is available, perform leak testing

Specifications

Measuring range (N ₂ and Air):		1×10 ⁻⁸ to 5×10 ⁻³ Torr
Cold cathode		
Accuracy Cathode ⁽¹⁾	1×10 ⁻⁸ to 1×10 ⁻³ Torr:	±30% of reading
Supply Voltage:		9 – 30 VDC
Power consumption:		< 2 Watt
Fuse (thermal recoverable):		200 mA
Analog output (MKS standard):		1-9 VDC
Analog output 1 resolution:		16 bit
Analog output 2 resolution:		12 bit
Analog output impedance:		100 Ω
Analog output update rate:		16 Hz
Setpoint relay range:		1×10 ⁻⁸ to 5×10 ⁻³ Torr
Setpoint relay contact rating:		1A / 30 VDC/AC (resistive load)
Setpoint relay contact resistance:		100 mΩ (max)
Setpoint relay contact endurance (30VDC/1A load):		100.000 (min)
Setpoint relay contact endurance (30VDC/0.2A load):		2.000.000 (min)
Setpoint relay response time:		<100 ms
Materials exposed to vacuum:		304 stainless steel 403 stainless steel Ceramic (Al ₂ O ₃), Viton® Low out gassing epoxy resin
Internal volume:	KF25 flange CF2.75" flange KF40 flange	3.6 cm ³ 1.9 cm ³ 3.1 cm ³
Housing material:		Stainless steel 304
Flange material:		Stainless steel 304
Weight:	KF25 flange CF2.75" flange KF40 flange	360 g 570 g 390 g
Operating temperature:		0 to 40 °C (32 to 104 °F)
Bake out temperature (Power off):		85 °C (185 °F)

(1) Accuracy and repeatability are typical values measured in Nitrogen atmosphere after zero adjustment at ambient temperature.

Dimensions KF25 flange (P/N: 971-2xxx)

mm. [Inch.]

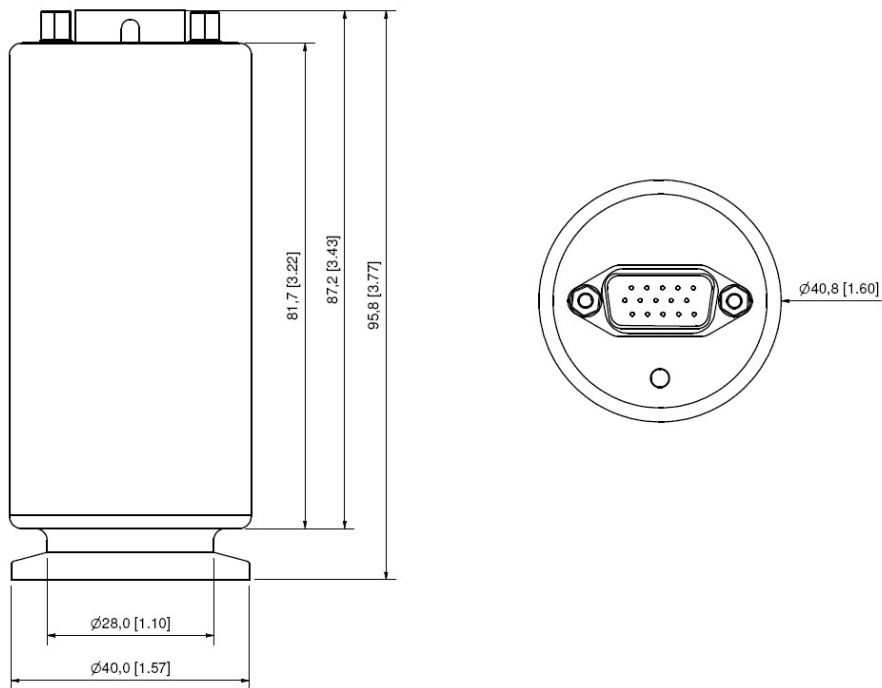

Dimensions CF2.75" flange (P/N: 971-7xxx)

mm. [Inch.]

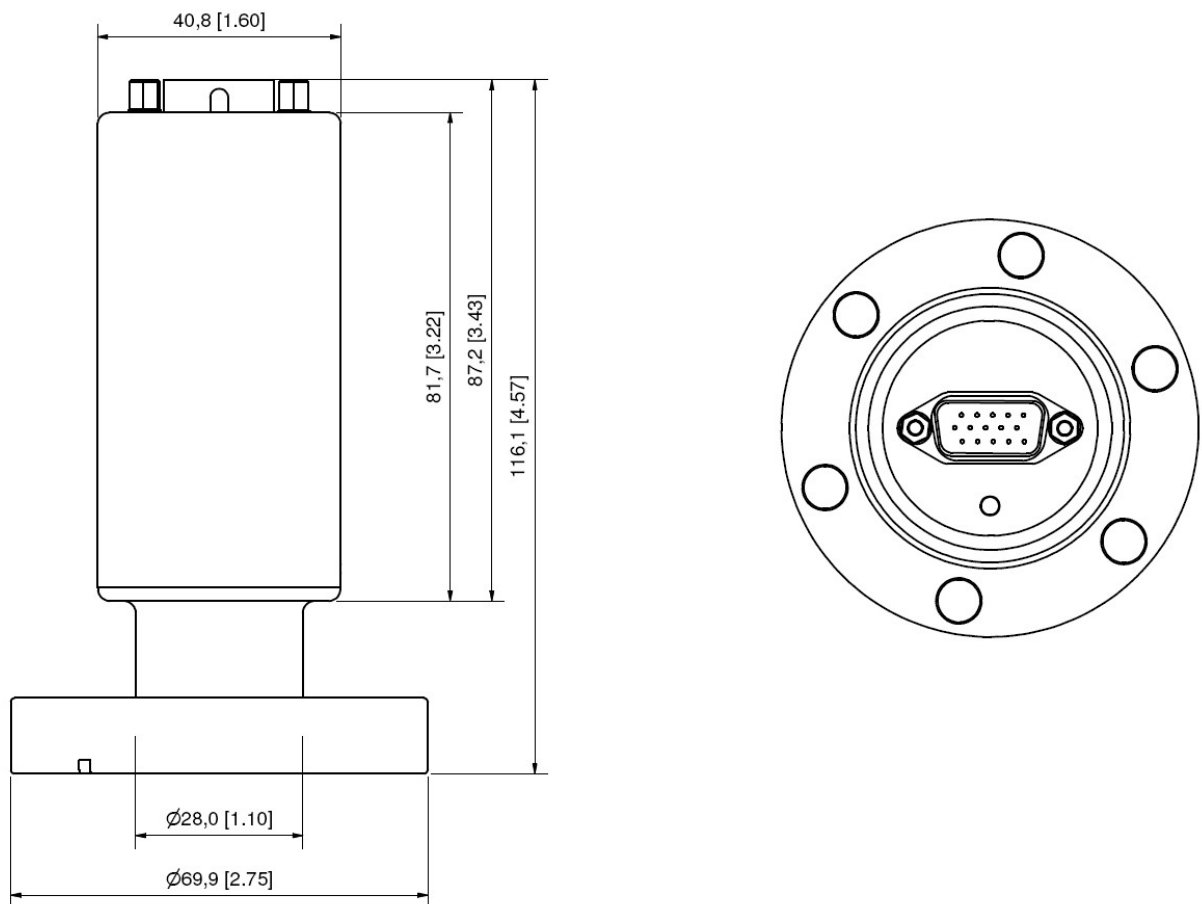

Dimensions KF40 flange (P/N: 971-9xxx)

mm. [Inch.]

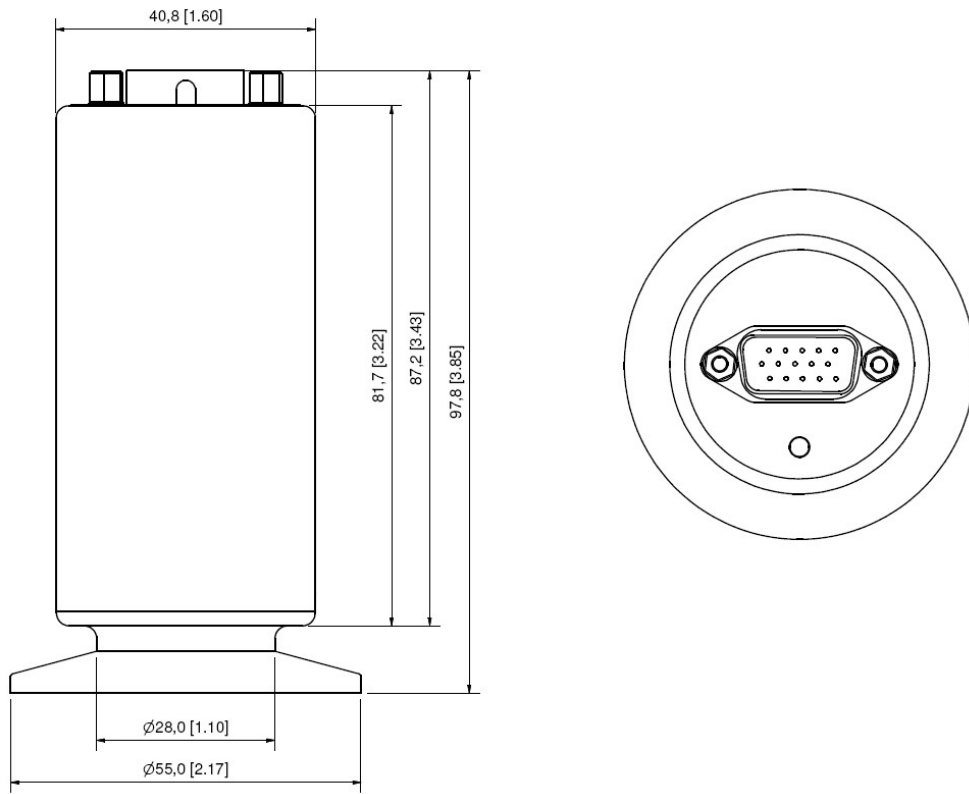

Accessories and replacement part numbers

PDR900 controller

Part number	Description	Interface
PDR900-12-EU	PDR900 Controller	EU Schuko power cable
PDR900-12-US	PDR900 Controller	US power cable
PDR900-12-UK	PDR900 Controller	UK power cable
PDR900-12-JP	PDR900 Controller	JP power cable. mbar / Pascal unit
PDR900-12-DK	PDR900 Controller	Danish power cable



PDR900 Transducer Cables for 971 (15 pin HD DSUB)

For transducer part number: 971-x12x, 971-x13x, 971-x15x

Part number	Description	Interface
100013620	3 m (10ft.)	RS232
100013621	5 m (16ft.)	RS232
100013622	7.6m (25ft.)	RS232
100013623	10 m (33ft.)	RS232

For transducer part number: 971-x22x, 971-x23x, 971-x25x

Part number	Description	Interface
100013671	3 m (10ft.)	RS485
100013672	5 m (16ft.)	RS485
100013673	7.6m (25ft.)	RS485
100013674	10 m (33ft.)	RS485

PDR900 Connectors & cables

Part number	Description
100010757	Setpoint Relay 3 pin connector
100013638	Analog output 8 pin connector
100013686	Analog output cable 3 meter (10ft.)
100013693	RS232/RS485 user communication cable 3 meter (10ft.)

PDR900 Mounting hardware

Part number	Description
100013689	¼.19" Rack mounting kit
100013690	Panel mounting kit
100013691	Front panel protection panel
100013692	Front panel protection panel w/key

971 Transducer calibration certificate

Part number	Description
100013147	DKD Calibration certificate Europe
100013200	Internal Calibration certificate Europe

971 Transducer repair kit

Part number	Description
971-2REP	971 Sensor repair kit. KF25 flange
971-7REP	971 Sensor repair kit CF2.75"flange
971-9REP	971 Sensor repair kit. KF40 flange
970-ANODEKIT	Anode kit for 970 Series cold cathode Transducers
100017192	Torx Driver, for Anode change
100017193	Circlip ring plier

CE Declaration of Conformity

Manufacturer: **MKS Denmark ApS
Ndr. Strandvej 119G
DK-3150 Hellebaek
Denmark**



Model: **971 UniMag**

Type of Equipment: **Vacuum pressure transducer**

Application of Council Directive(s): **2004/108/EC Electromagnetic Compatibility**

Standard(s) to which conformity is declared:

EN61326-1:2006 EMC requirements for electrical equipment for measurement, control and laboratory use. (Industrial location).

Emissions

EN 55011:1997 Limits and Methods of measurements of radio disturbances characteristic of industrial, scientific, and medical RF equipment (Class B, Group 1)

Immunity

EN 61000-4-2 Electrostatic discharge
EN 61000-4-3 Radiated RF electromagnetic fields
EN 61000-4-4 EFT/burst
EN 61000-4-6 Conducted disturbances by RF fields

Safety

EN 61010-1:2001 Safety Requirements for Electrical Equipment for Measurement, Control, and Laboratory Use

I, the undersigned, hereby declare that the equipment above conforms to the above Directive(s) and Standard(s) when installed in accordance with specifications specified in this short form manual and Operation and Installation manual.

MKS Denmark ApS. Hellebaek. Denmark
July 1, 2009

Ole Wenzel – Managing Director

PDR 900 Display and power supply

- Plug and play readout for 900 Series transducers
- The easy way for setup and configuration
- Data logger tool for data analysing



See more on

www.mksinst.com/pdr900

Index

Accessories and replacement part numbers	35	NAK Code	10
Accuracy	32	NAK180	13;19;30
Addressing	11	Operating temperature	32
Analog output	21;28	Part number	3
Applications	4;28	Part Number	20
Bake out	6	PDR900	35
Bake out temperature	32	PDR900 controller relays	12
Baud rate	11	Pressure output	15;16
Calibration and adjustment	17	Process compatibility	6
Calibration certificate	35	Query Command list	26
CE Declaration of Conformity	36	RS232 user interface	9
CE marking	2	RS485 user interface	9
Communication delay	11	Safety information	2
Communication Protocol	10	Sensor Check	20
Communication software	10	Sensor technology	4
Contamination	6	Serial Number	20
Device Type	20	Serial user interface	9
Dimensions	33	Service and repair	2;29
Display	14	Service and Repair	31
Disposal	4	Setpoint functionality	12
Explosive Environments	2;6	Setpoint relay	12
Factory default	18	Setup and configuration command list	27
Firmware Version	20	Specifications	32
Frequently Asked Questions	28	Supply Voltage	32
Fuse	2;32	Temperature	6
Grounding	2	Termination resistor	9
Hardware Version	20	Time ON	20
Inductive relay load	12	Transducer installation (electrical)	7
Input/Output Wiring	8	Transducer installation (mechanical)	6
Internal volume	32	Trouble shooting	30
LED Status Indicator	5	Unit calibration	17
Lock function	19	Unpacking	3
Magnetic interference	2	User Switch	5;19
Manufacturer	20	Vacuum connections	6
Model	20	Warranty	2

P/N: 100017133
971 UniMag™ Transducer
Operation and Installation Manual
Revision: C, January, 2010