



MKS e-Baratron[®] Type 62xC/E2xC Capacitance Manometer with TOOLweb[®] Enabled Ethernet[™] Interface

Instruction Manual

Six Shattuck Road
Andover
MA 01810-2449

Main: 978.645.5500
USA: 800.227.8766
www.mksinst.com

1004661-001
Rev A, 4/09



WARRANTY

Type 62xC and E2xC Equipment

MKS Instruments, Inc. (**MKS**) warrants that for two years from the date of shipment the equipment described above (the "equipment") manufactured by **MKS** shall be free from defects in materials and workmanship and will correctly perform all date-related operations, including without limitation accepting data entry, sequencing, sorting, comparing, and reporting, regardless of the date the operation is performed or the date involved in the operation, provided that, if the equipment exchanges data or is otherwise used with equipment, software, or other products of others, such products of others themselves correctly perform all date-related operations and store and transmit dates and date-related data in a format compatible with **MKS** equipment. THIS WARRANTY IS **MKS'** SOLE WARRANTY CONCERNING DATE-RELATED OPERATIONS.

For the period commencing with the date of shipment of this equipment and ending two years later, **MKS** will, at its option, either repair or replace any part which is defective in materials or workmanship or with respect to the date-related operations warranty without charge to the purchaser. The foregoing shall constitute the exclusive and sole remedy of the purchaser for any breach by **MKS** of this warranty.

The purchaser, before returning any equipment covered by this warranty, which is asserted to be defective by the purchaser, shall make specific written arrangements with respect to the responsibility for shipping the equipment and handling any other incidental charges with the **MKS** sales representative or distributor from which the equipment was purchased or, in the case of a direct purchase from **MKS**, with the **MKS** home office in Andover, Massachusetts, USA.

This warranty does not apply to any equipment which has not been installed and used in accordance with the specifications recommended by **MKS** for the proper and normal use of the equipment. **MKS** shall not be liable under any circumstances for indirect, special, consequential, or incidental damages in connection with, or arising out of, the sale, performance, or use of the equipment covered by this warranty.

MKS recommends that all **MKS** pressure and flow products be calibrated periodically (typically every 6 to 12 months) to ensure accurate readings. When a product is returned to **MKS** for this periodic re-calibration it is considered normal preventative maintenance not covered by any warranty.

THIS WARRANTY IS IN LIEU OF ALL OTHER RELEVANT WARRANTIES, EXPRESSED OR IMPLIED, INCLUDING THE IMPLIED WARRANTY OF MERCHANTABILITY AND THE IMPLIED WARRANTY OF FITNESS FOR A PARTICULAR PURPOSE, AND ANY WARRANTY AGAINST INFRINGEMENT OF ANY PATENT.

SPECIAL NOTICE

This warranty is void if the product is installed using single or double metal ferrule compression type vacuum fittings, shown below. These fittings are commonly tightened incorrectly, causing damage to the pressure sensor.

Single Ferrule

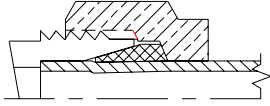

Double Ferrule

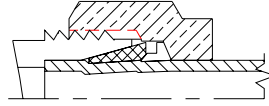

**MKS e-Baratron®
Type 62xC/E2xC
Capacitance Manometer
with TOOLweb® Enabled
Ethernet™ Interface**

Copyright © 2009 by MKS Instruments, Inc.

All rights reserved. No part of this work may be reproduced or transmitted in any form or by any means, electronic or mechanical, including photocopying and recording, or by any information storage or retrieval system, except as may be expressly permitted in writing by MKS Instruments, Inc.

Printed in the United States of America

e-Baratron® and TOOLweb® are registered trademarks of MKS Instruments, Inc., Andover, MA

Ethernet™ is a trademark of Open Ethernet Vendor Association, Coral Springs, FL

Inconel® is a registered trademark of Inco Alloys International, Huntington, WV

Java™ is a trademark of Sun Microsystems.

SEMI® is a registered trademark of Semiconductor Equipment and Materials International, Mountain View, CA

Swagelok®, VCR®, and VCO® are registered trademarks of Swagelok Marketing Co., Solon, OH

Windows® is a registered trademark of Microsoft Corporation.

Table of Contents

Manometer Safety Information.....	1
Symbols Used in This Instruction Manual	1
Symbols Found on the Unit	1
Safety Procedures and Precautions	1
Sicherheitsdaten Manometer.....	3
In dieser Betriebsanleitung vorkommende Symbole	3
Erklärung der am Gerät angebrachten Symbole	3
Sicherheitsvorschriften und Vorsichtsmaßnahmen.....	4
Informations de sécurité relatives au manomètre	5
Symboles utilisés dans ce manuel d'utilisation	5
Symboles figurant sur l'unité.....	5
Mesures de sécurité et précautions	5
Medidas de seguridad del manómetro.....	7
Símbolos usados en este manual de instrucciones	7
Símbolos hallados en la unidad	7
Procedimientos y precauciones de seguridad	7
Chapter One: General Information.....	9
Introduction	9
How This Manual is Organized.....	10
Customer Support.....	10
Chapter Two: Installation	11
How To Unpack the 62xC/E2xC.....	11
Interface Cables.....	11
Product Location and Requirements.....	13
Setup.....	14
Electrical Information.....	15
Startup	18
Chapter Three: Overview	21
General Information	21
Sensor	21
Signal Conditioner/Electronics.....	21
Pressure Measurement.....	22
Top Panel Components.....	22
Chapter Four: Operation of Ethernet Interface.....	25
MAC IDs and IP Address	25
Web Page Monitor Privileges.....	25
Connecting to the 600C Using the Ethernet Interface	26
Description of Web Pages	28
Chapter Five: Maintenance and Troubleshooting	46
General Information	46

Maintenance	46
Troubleshooting.....	47
Appendix A: Product Specifications	49
Appendix B: Model Code Explanation	53
Model Code	53

List of Figures

Figure 1: 62xC/E2xC Dimensions	14
Figure 2: Serial Number Label.....	15
Figure 3: 62xC Power Supply Ground Configuration	16
Figure 4: Analog and Digital Pressure Calculation (Patented)	23
Figure 5: Device Page	29
Figure 6: Device/Events Page	30
Figure 7: Device/Information Page.....	31
Figure 8: Plot Page.....	32
Figure 9: Diagnostics Page	33
Figure 10: Configuration Page.....	34
Figure 11: Configuration/Network Settings Page	35
Figure 12: Configuration/ Limit Setting Page.....	36
Figure 17: Push-Button Zero with No Offset.....	43
Figure 18: Push-Button Zero with Zero Offset = x Fraction of FS.....	44
Figure 19: Push-Button Zero with Target Offset = x Fraction of FS.....	45

List of Tables

Table 1: Definition of Symbols Found on the Unit.....	1
Tabelle 2: Bedeutung der am Gerät angebrachten Symbole	3
Tableau 3: Définition des symboles sur l'unité	5
Tabla 4: Definición de los símbolos hallados en la unidad.....	7
Table 5: MKS Interface Cables.....	12
Table 6: Suggested Ethernet Communication Connectors.....	13
Table 7: Ambient Operating Temperature	13
Table 8: Power Requirements	13
Table 9: 15-Pin Interface Connector Pin Assignments	17
Table 10: 9-Pin Interface Connector Pin Assignments	17
Table 11: Lowest Suggested Pressures for Reading and Control	19
Table 12: Status LED.....	22
Table 13: Highest Pressures Suggested for Proper Zero Adjustment	42
Table 14: Troubleshooting Chart	47

Manometer Safety Information

Symbols Used in This Instruction Manual

Definitions of WARNING, CAUTION, and NOTE messages used throughout the manual.



Warning

The **WARNING** sign denotes a hazard. It calls attention to a procedure, practice, condition, or the like, which, if not correctly performed or adhered to, could result in injury to personnel.



Caution

The **CAUTION** sign denotes a hazard. It calls attention to an operating procedure, practice, or the like, which, if not correctly performed or adhered to, could result in damage to or destruction of all or part of the product.















Note

The **NOTE** sign denotes important information. It calls attention to a procedure, practice, condition, or the like, which is essential to highlight.

Symbols Found on the Unit

The following table describes symbols that may be found on the unit.

Table 1: Definition of Symbols Found on the Unit

 On (Supply) IEC 417, No. 5007	 Off (Supply) IEC 417, No. 5008	 Earth (ground) IEC 417, No. 5017	 Protective Earth (ground) IEC 417, No. 5019
 Frame or Chassis IEC 417, No. 5020	 Equipotentiality IEC 417, No. 5021	 Direct Current IEC 417, No. 5031	 Alternating Current IEC 417, No. 5032
 Both Direct and Alternating Current IEC 417, No. 5033-a	 Class II Equipment IEC 417, No. 5172-a	 Three Phase Alternating Current IEC 617-2, No. 020206	
 Caution (refer to accompanying documents) ISO 3864, No. B.3.1	 Caution, Risk of Electric Shock ISO 3864, No. B.3.6	 Caution, Hot Surface IEC 417, No. 5041	

Safety Procedures and Precautions

Observe the following general safety precautions during all phases of operation of this instrument. Failure to comply with these precautions or with specific warnings elsewhere in this manual violates safety standards of intended use of the instrument and may impair the protection provided by the equipment. MKS Instruments, Inc. assumes no liability for the customer's failure to comply with these requirements.

DO NOT SUBSTITUTE PARTS OR MODIFY INSTRUMENT

Do not install substitute parts or perform any unauthorized modification to the instrument. Return the instrument to an MKS Calibration and Service Center for service and repair to ensure that all safety features are maintained.

SERVICE BY QUALIFIED PERSONNEL ONLY

Operating personnel must not remove instrument covers. Component replacement and internal adjustments must be made by qualified service personnel only.

USE CAUTION WHEN OPERATING WITH HAZARDOUS MATERIALS

If hazardous materials are used, users must take responsibility to observe the proper safety precautions, completely purge the instrument when necessary, and ensure that the material used is compatible with the materials in this product, including any sealing materials.

PURGE THE INSTRUMENT

After installing the unit, or before removing it from a system, purge the unit completely with a clean, dry gas to eliminate all traces of the previously used flow material.

USE PROPER PROCEDURES WHEN PURGING

This instrument must be purged under a ventilation hood, and gloves must be worn to protect personnel.

DO NOT OPERATE IN AN EXPLOSIVE ENVIRONMENT

To avoid explosion, do not operate this product in an explosive environment unless it has been specifically certified for such operation.

USE PROPER FITTINGS AND TIGHTENING PROCEDURES

All instrument fittings must be consistent with instrument specifications, and compatible with the intended use of the instrument. Assemble and tighten fittings according to manufacturer's directions.

CHECK FOR LEAK-TIGHT FITTINGS

Before proceeding to instrument setup, carefully check all plumbing connections to the instrument to ensure leak-tight installation.

OPERATE AT SAFE INLET PRESSURES

This unit should never be operated at pressures higher than the rated maximum pressure (refer to the product specifications for the maximum allowable pressure).

INSTALL A SUITABLE BURST DISC

When operating from a pressurized gas source, install a suitable burst disc in the vacuum system to prevent system explosion should the system pressure rise.

KEEP THE UNIT FREE OF CONTAMINANTS

Do not allow contaminants of any kind to enter the unit before or during use. Contamination such as dust, dirt, lint, glass chips, and metal chips may permanently damage the unit.

ALLOW PROPER WARM UP TIME FOR TEMPERATURE-CONTROLLED UNITS

Temperature-controlled unit will only meet specifications when sufficient time is allowed for the unit to meet, and stabilize at, the designed operating temperature. Do not zero or calibrate the unit until the warm up is complete.

Sicherheitsdaten Manometer

In dieser Betriebsanleitung vorkommende Symbole

Bedeutung der mit WARNUNG!, VORSICHT! und HINWEIS gekennzeichneten Absätze in dieser Betriebsanleitung.



Warnung! Das Symbol **WARNUNG!** weist auf eine Gefahr für das Bedienpersonal hin. Es macht auf einen Arbeitsablauf, eine Arbeitsweise, einen Zustand oder eine sonstige Gegebenheit aufmerksam, deren unsachgemäße Ausführung bzw. ungenügende Berücksichtigung zu Verletzungen führen kann.



Vorsicht! Das Symbol **VORSICHT!** weist auf eine Gefahr für das Gerät hin. Es macht auf einen Bedienungsablauf, eine Arbeitsweise oder eine sonstige Gegebenheit aufmerksam, deren unsachgemäße Ausführung bzw. ungenügende Berücksichtigung zu einer Beschädigung oder Zerstörung des Gerätes oder von Teilen des Gerätes führen kann.



Hinweis Das Symbol **HINWEIS** macht auf wichtige Informationen bezüglich eines Arbeitsablaufs, einer Arbeitsweise, eines Zustands oder einer sonstige Gegebenheit aufmerksam.

Erklärung der am Gerät angebrachten Symbole

Nachstehender Tabelle sind die Bedeutungen der Symbole zu entnehmen, die am Gerät angebracht sein können.

Tabelle 2: Bedeutung der am Gerät angebrachten Symbole

 Ein (Energie) IEC 417, No.5007	 Aus (Energie) IEC 417, No.5008	 Erdanschluss IEC 417, No.5017	 Schutzleiteranschluss IEC 417, No.5019
 Masseanschluss IEC 417, No.5020	 Aquipotentialanschluss IEC 417, No.5021	 Gleichstrom IEC 417, No.5031	 Wechselstrom IEC 417, No.5032
 Gleich- oder Wechselstrom IEC 417, No.5033-a	 Durchgängige doppelte oder verstärkte Isolierung IEC 417, No.5172-a	 Dreileiter-Wechselstrom (Drehstrom) IEC 617-2, No.020206	
 Warnung vor einer Gefahrenstelle (Achtung, Dokumentation beachten) ISO 3864, No.B.3.1	 Warnung vor gefährlicher elektrischer Spannung ISO 3864, No.B.3.6	 Höhere Temperatur an leicht zugänglichen Teilen IEC 417, No.5041	

Sicherheitsvorschriften und Vorsichtsmaßnahmen

Folgende allgemeine Sicherheitsvorschriften sind während allen Betriebsphasen dieses Gerätes zu befolgen. Eine Missachtung der Sicherheitsvorschriften und sonstiger Warnhinweise in dieser Betriebsanleitung verletzt die für dieses Gerät und seine Bedienung geltenden Sicherheitsstandards, und kann die Schutzvorrichtungen an diesem Gerät wirkungslos machen. MKS Instruments, Inc. haftet nicht für Missachtung dieser Sicherheitsvorschriften seitens des Kunden.

Niemals Teile austauschen oder Änderungen am Gerät vornehmen!

Ersetzen Sie keine Teile mit baugleichen oder ähnlichen Teilen, und nehmen Sie keine eigenmächtigen Änderungen am Gerät vor. Schicken Sie das Gerät zwecks Wartung und Reparatur an den MKS-Kalibrierungs- und -Kundendienst ein. Nur so wird sichergestellt, dass alle Schutzvorrichtungen voll funktionsfähig bleiben.

Wartung nur durch qualifizierte Fachleute!

Das Auswechseln von Komponenten und das Vornehmen von internen Einstellungen darf nur von qualifizierten Fachleuten durchgeführt werden, niemals vom Bedienpersonal.

Vorsicht beim Arbeiten mit gefährlichen Stoffen!

Wenn gefährliche Stoffe verwendet werden, muß der Bediener die entsprechenden Sicherheitsvorschriften genauestens einhalten, das Gerät, falls erforderlich, vollständig spülen, sowie sicherstellen, daß der Gefahrstoff die am Gerät verwendeten Materialien, insbesondere Dichtungen, nicht angreift.

Spülen des Gerätes mit Gas!

Nach dem Installieren oder vor dem Ausbau aus einem System muß das Gerät unter Einsatz eines reinen Trockengases vollständig gespült werden, um alle Rückstände des Vorgängermediums zu entfernen.

Anweisungen zum Spülen des Gerätes

Das Gerät darf nur unter einer Ablufthaube gespült werden. Schutzhandschuhe sind zu tragen.

Gerät nicht zusammen mit explosiven Stoffen, Gasen oder Dämpfen benutzen!

Um der Gefahr einer Explosion vorzubeugen, darf dieses Gerät niemals zusammen mit (oder in der Nähe von) explosiven Stoffen aller Art eingesetzt werden, sofern es nicht ausdrücklich für diesen Zweck zugelassen ist.

Anweisungen zum Installieren der Armaturen!

Alle Anschlussstücke und Armaturenteile müssen mit der Gerätespezifikation übereinstimmen, und mit dem geplanten Einsatz des Gerätes kompatibel sein. Der Einbau, insbesondere das Anziehen und Abdichten, muss gemäß den Anweisungen des Herstellers vorgenommen werden.

Verbindungen auf Undichtigkeiten prüfen!

Überprüfen Sie sorgfältig alle Verbindungen der Vakuumkomponenten auf undichte Stellen.

Gerät nur unter zulässigen Anschlussdrücken betreiben!

Betreiben Sie das Gerät niemals unter Drücken, die den maximal zulässigen Druck (siehe Produktspezifikationen) übersteigen.

Geeignete Berstscheibe installieren!

Wenn mit einer unter Druck stehenden Gasquelle gearbeitet wird, sollte eine geeignete Berstscheibe in das Vakuumsystem installiert werden, um eine Explosionsgefahr aufgrund von steigendem Systemdruck zu vermeiden.

Verunreinigungen im Gerät vermeiden!

Stellen Sie sicher, dass Verunreinigungen jeglicher Art weder vor dem Einsatz noch während des Betriebs in das Instrumenteninnere gelangen können. Staub- und Schmutzpartikel, Glassplitter oder Metallspäne können das Gerät dauerhaft beschädigen oder Prozess- und Messwerte verfälschen.

Bei Geräten mit Temperaturkontrolle korrekte Anwärmzeit einhalten!

Temperaturkontrollierte Geräte arbeiten nur dann gemäß ihrer Spezifikation, wenn genügend Zeit zum Erreichen und Stabilisieren der Betriebstemperatur eingeräumt wird. Kalibrierungen und Nulleinstellungen sollten daher nur nach Abschluss des Anwärmvorgangs durchgeführt werden.

Informations de sécurité relatives au manomètre

Symboles utilisés dans ce manuel d'utilisation

Définitions des indications AVERTISSEMENT, ATTENTION, et REMARQUE utilisées dans ce manuel.



Avertissement

L'indication **AVERTISSEMENT** signale un danger pour le personnel. Elle attire l'attention sur une procédure, une pratique, une condition, ou toute autre situation présentant un risque d'accident pour le personnel, en cas d'exécution incorrecte ou de non-respect des consignes.



Attention

L'indication **ATTENTION** signale un danger pour l'appareil. Elle attire l'attention sur une procédure d'exploitation, une pratique, ou toute autre situation, présentant un risque de dégât ou de destruction partielle ou totale du produit, en cas d'exécution incorrecte ou de non-respect des consignes.















Remarque

L'indication **REMARQUE** signale une information importante. Elle attire l'attention sur une procédure, une pratique, une condition, ou toute autre situation, présentant un intérêt particulier.

Symboles figurant sur l'unité

Le tableau suivant décrit les symboles pouvant apparaître sur l'unité.

Tableau 3: Définition des symboles sur l'unité

 Marche (sous tension) IEC 417, No.5007	 Arrêt (hors tension) IEC 417, No.5008	 Terre (masse) IEC 417, No.5017	 Terre de protection (masse) IEC 417, No.5019
 Masse IEC 417, No.5020	 Equipotentialité IEC 417, No.5021	 Courant continu IEC 417, No.5031	 Courant alternatif IEC 417, No.5032
 Courant continu et alternatif IEC 417, No.5033-a	 Matériel de classe II IEC 417, No.5172-a	 Courant alternatif triphasé IEC 617-2, No.020206	
 Attention : se reporter à la documentation ISO 3864, No.B.3.1	 Attention : risque de choc électrique ISO 3864, No.B.3.6	 Attention : surface brûlante IEC 417, No.5041	

Mesures de sécurité et précautions

Observer les précautions générales de sécurité suivantes pendant toutes les phases d'exploitation de cet appareil. Le non-respect des ces précautions ou des avertissements du manuel constitue une violation des normes de sécurité relatives à l'utilisation de l'appareil et peut compromettre la protection assurée

par l'appareil. MKS Instruments, Inc. rejette toute responsabilité en cas de non-respect des consignes par les clients.

PAS DE REMPLACEMENT DE PIÈCES OU DE MODIFICATION DE L'APPAREIL

Ne pas installer de pièces de remplacement ni effectuer des modifications non autorisées sur l'appareil. Renvoyer l'appareil à un centre de service et de calibrage MKS pour tout dépannage ou réparation afin de garantir le l'intégrité des dispositifs de sécurité.

DÉPANNAGE UNIQUEMENT PAR DU PERSONNEL QUALIFIÉ

Le personnel d'exploitation ne doit pas essayer de sortir les composants du boîtier ou faire des réglages internes. Le dépannage est réservé au personnel qualifié.

PRÉCAUTION EN CAS D'UTILISATION AVEC DES PRODUITS DANGEREUX

Si des produits dangereux sont utilisés, l'utilisateur est responsable de la prise des mesures de précaution appropriées, de la purge complète de l'appareil quand cela est nécessaire, et de la garantie que les produits utilisés sont compatibles avec les composants de cet appareil, y compris les matériaux d'étanchéité.

PURGE DE L'APPAREIL

Après l'installation de l'unité, ou avant son enlèvement d'un système, purger l'unité complètement avec un gaz propre et sec afin d'éliminer toute trace du produit de flux utilisé précédemment.

UTILISATION DES PROCÉDURES APPROPRIÉES POUR LA PURGE

Cet appareil doit être purgé sous une hotte de ventilation. Le personnel doit porter des gants de protection.

PAS D'EXPLOITATION DANS UN ENVIRONNEMENT EXPLOSIF

Pour éviter toute explosion, ne pas utiliser cet appareil dans un environnement explosif, sauf en cas d'homologation spécifique pour une telle exploitation.

UTILISATION D'ÉQUIPEMENTS ET PROCÉDURES DE SERRAGE APPROPRIÉS

Tous les équipements de l'appareil doivent être conformes à ses spécifications, et compatibles avec l'utilisation prévue de l'appareil. Assembler et serrer les équipements conformément aux directives du fabricant.

VÉRIFICATION DE L'ÉTANCHÉITÉ DES CONNEXIONS

Vérifier attentivement toutes les connexions des composants pour le vide afin de garantir l'étanchéité de l'installation.

EXPLOITATION AVEC DES PRESSIONS D'ENTRÉE NON DANGEREUSES

Ne jamais utiliser des pressions supérieures à la pression nominale maximum (se reporter aux spécifications de l'unité pour la pression maximum admissible).

INSTALLATION D'UN DISQUE D'ÉCHAPPEMENT ADAPTÉ

En cas d'exploitation avec une source de gaz pressurisé, installer un disque d'échappement adapté dans le système à vide, afin d'éviter une explosion du système en cas d'augmentation de la pression.

MAINTIEN DE L'UNITÉ À L'ABRI DES CONTAMINATIONS

Ne pas laisser des produits contaminants pénétrer dans l'unité avant ou pendant l'utilisation. Des produits contaminants tels que des poussières et des fragments de tissu, de verre et de métal peuvent endommager l'unité de manière permanente.

RESPECT DU TEMPS D'ÉCHAUFFEMENT APPROPRIÉ POUR LES UNITÉS À RÉGULATION DE TEMPÉRATURE

Les unités à régulation de température sont conformes à leurs spécifications uniquement quand on leur laisse un temps suffisant pour atteindre d'une manière stable la température d'exploitation. Ne pas remettre à zéro ou calibrer l'unité tant que l'échauffement n'est pas terminé.

Medidas de seguridad del manómetro

Símbolos usados en este manual de instrucciones

Definiciones de los mensajes de advertencia, precaución y de las notas usados en el manual.



Advertencia

El símbolo de advertencia indica la posibilidad de que se produzcan daños personales. Pone de relieve un procedimiento, práctica, estado, etc. que en caso de no realizarse o cumplirse correctamente puede causar daños personales.



Precaución

El símbolo de precaución indica la posibilidad de producir daños al equipo. Pone de relieve un procedimiento operativo, práctica, etc. que en caso de no realizarse o cumplirse correctamente puede causar daños o la destrucción total o parcial del equipo.



Nota

El símbolo de notas indica información de importancia. Este símbolo pone de relieve un procedimiento, práctica o condición cuyo conocimiento es esencial destacar.

Símbolos hallados en la unidad

La tabla siguiente contiene los símbolos que puede hallar en la unidad.

Tabla 4: Definición de los símbolos hallados en la unidad

 Encendido (alimentación eléctrica) IEC 417, N° 5007	○ Apagado (alimentación eléctrica) IEC 417, N° 5008	⏏ Puesta a tierra IEC 417, N° 5017	⏏ Protección a tierra IEC 417, N° 5019
⏏ Caja o chasis IEC 417, N° 5020	⏏ Equipotencialidad IEC 417, N° 5021	≡ Corriente continua IEC 417, N° 5031	~ Corriente alterna IEC 417, N° 5032
~ Corriente continua y alterna IEC 417, N° 5033-a	□ Equipo de clase II IEC 417, N° 5172-a	3~ Corriente alterna trifásica IEC 617-2, N° 020206	
⚠ Precaución. Consulte los documentos adjuntos ISO 3864, N° B.3.1	⚡ Precaución. Riesgo de descarga eléctrica ISO 3864, N° B.3.6	🔥 Precaución. Superficie caliente IEC 417, N° 5041	

Procedimientos y precauciones de seguridad

Las medidas generales de seguridad descritas a continuación deben observarse durante todas las etapas de funcionamiento del instrumento. La falta de cumplimiento de dichas medidas de seguridad o de las advertencias específicas a las que se hace referencia en otras partes de este manual, constituye una violación de las normas de seguridad establecidas para el uso previsto del instrumento y podría anular

la protección proporcionada por el equipo. Si el cliente no cumple dichas precauciones y advertencias, MKS Instruments, Inc. no asume responsabilidad legal alguna.

NO UTILICE PIEZAS NO ORIGINALES O MODIFIQUE EL INSTRUMENTO

No instale piezas que no sean originales ni modifique el instrumento sin autorización. Para asegurar el correcto funcionamiento de todos los dispositivos de seguridad, envíe el instrumento al Centro de servicio y calibración de MKS toda vez que sea necesario repararlo o efectuar tareas de mantenimiento.

LAS REPARACIONES DEBEN SER EFECTUADAS ÚNICAMENTE POR TÉCNICOS AUTORIZADOS

Los operarios no deben retirar las tapas del instrumento. El reemplazo de los componentes y las tareas de ajuste deben ser realizadas únicamente por personal autorizado.

TENGA CUIDADO CUANDO TRABAJE CON MATERIALES TÓXICOS

Cuando se utilicen materiales tóxicos, es responsabilidad de los operarios tomar las medidas de seguridad correspondientes, purgar totalmente el instrumento cuando sea necesario y comprobar que el material utilizado sea compatible con los materiales del instrumento e inclusive, con todos los materiales de sellado.

PURGUE EL INSTRUMENTO

Una vez instalada la unidad o antes de retirarla del sistema, purgue completamente la unidad con gas limpio y seco para eliminar todo resto de la sustancia líquida empleada anteriormente.

USE PROCEDIMIENTOS ADECUADOS PARA REALIZAR LA PURGA

El instrumento debe purgarse debajo de una campana de ventilación y deben utilizarse guantes protectores.

NO HAGA FUNCIONAR EL INSTRUMENTO EN AMBIENTES CON RIESGO DE EXPLOSIÓN

Para evitar que se produzcan explosiones, no haga funcionar este instrumento en un ambiente con riesgo de explosiones, excepto cuando el mismo haya sido certificado específicamente para tal uso.

USE ACCESORIOS ADECUADOS Y REALICE CORRECTAMENTE LOS PROCEDIMIENTOS DE AJUSTE

Todos los accesorios del instrumento deben cumplir las especificaciones del mismo y ser compatibles con el uso que se debe dar al instrumento. Arme y ajuste los accesorios de acuerdo con las instrucciones del fabricante.

COMPRUEBE QUE LOS ACCESORIOS SEAN A PRUEBA DE FUGAS

Antes de proceder con la instalación del instrumento, inspeccione cuidadosamente todas las conexiones de las tuberías para comprobar que hayan sido instaladas a prueba de fugas.

HAGA FUNCIONAR EL INSTRUMENTO CON PRESIONES DE ENTRADA SEGURAS

No haga funcionar nunca el instrumento con presiones superiores a la máxima presión nominal (en las especificaciones del instrumento hallará la presión máxima permitida).

INSTALE UNA CÁPSULA DE SEGURIDAD ADECUADA

Cuando el instrumento funcione con una fuente de gas presurizado, instale una cápsula de seguridad adecuada en el sistema de vacío para evitar que se produzcan explosiones cuando suba la presión del sistema.

MANTENGA LA UNIDAD LIBRE DE CONTAMINANTES

No permita el ingreso de contaminantes en la unidad antes o durante su uso. Los productos contaminantes tales como polvo, suciedad, pelusa, lascas de vidrio o virutas de metal pueden dañar irreparablemente la unidad.

CALIENTE ADECUADAMENTE LAS UNIDADES CONTROLADAS POR MEDIO DE TEMPERATURA

Las unidades controladas por medio de temperatura funcionarán de acuerdo con las especificaciones sólo cuando se las caliente durante el tiempo suficiente para permitir que lleguen y se estabilicen a la temperatura de operación indicada. No calibre la unidad y no la ponga en cero hasta que finalice el procedimiento de calentamiento.

Chapter One: General Information

Introduction

The MKS e-Baratron® Type 62xC/E2xC Absolute Process Manometers with an Ethernet-enabled interface is part of the MKS family of general purpose process manometers designed to provide accurate, reliable, and repeatable pressure measurements in full-scale ranges from as low as 100 mTorr up to 1000T. The 62xC/E2xC is designed specifically to meet the needs of vacuum process systems where environmental and process conditions are particularly demanding.

The Ethernet interface on 62xC/E2xC includes a graphical user interface and is one of the new generation of MKS products that are TOOLweb® compliant. The TOOLweb ToolSide Protocol provides an open, XML-based interface between a server (sensor/instrument) and the client application such as the MKS Blue Box.

Please visit the following MKS Instruments Web site for more details on TOOLweb:

<http://www.mksinst.com/TOOLweb/>

The manometer can operate either with ± 15 VDC ($\pm 5\%$) or $+24$ VDC ($\pm 10\%$) input power. Refer to Table 8, page 13 for details.

Temperature control of the 627C/E27C (45° C) and 628C/E28C (100° C) manometers minimizes the effects of ambient or process temperature variations typically encountered in process line environments. The 627C/E27C controls its temperature at 45° C (nominal). The 628C/E28C manometer is internally controlled at 100° C (nominal), thereby minimizing contamination from the process.

The manometer provides an output signal that is linear with pressure. Pressure output is available as an analog 0 to 10 VDC signal and an Ethernet interface signal in selectable units of pressure through the Web browser embedded in the device. The analog signal is provided either through a 9-pin or 15-pin D-sub connector. Each device gets unique MAC ID and default user-resettable IP address for Ethernet communications via a standard RJ45 jack.

The 62xC/E2xC/E2xC unit exposes only Inconel® to the process, permitting use with corrosive or dirty gases and eliminating contamination of the process with manometer materials. Measurements are independent of gas composition. Using the latest single-sided, dual-electrode Inconel manometer design, coupled with a low impedance, fixed-frequency bridge signal conditioner, this instrument is capable of withstanding high overpressure conditions (45 psia) with minimal or no shifts in output over their range. The advanced bridge signal conditioning technology provides high accuracy and operation which is extremely temperature-stable at operating pressure.

The Type 627C/E27C manometer has an accuracy of 0.12% of reading for most pressure ranges (0.1 Torr units have an accuracy of 0.15% of reading). The Type 628C/E28C manometer has an accuracy of 0.25% of reading (0.1T units have an accuracy of 0.50% of reading).

Protection from RF interference and noisy electrical environments is enabled by the use of a metalized case and internal design elements as well as surge and ESD suppression networks and RFI filtering on all inputs and outputs.

The unit is available with a variety of fittings.

How This Manual is Organized

This manual is designed to provide instructions on setting up, installing, and operating a Type 62xC/E2xC/E2xC unit with an Ethernet Interface.

Before installing your Type 62xC/E2xC unit in a system and/or operating it, carefully read and familiarize yourself with all precautionary notes in the *Safety Messages and Procedures* section at the front of this manual. In addition, observe and obey all WARNING and CAUTION notes provided throughout the manual.

Chapter One: General Information (this chapter) introduces the product and describes the organization of the manual.

Chapter Two: Installation explains the environmental requirements and describes mounting the instrument in your system.

Chapter Three: Overview gives a brief description of the instrument and its functionality.

Chapter Four: Operation provides details of operation of the device instructions required to operate the unit by connecting to the Web browser and describes the diagnostic features available through the browser.

Chapter Five: Maintenance and Troubleshooting lists maintenance required to keep the unit in good working condition and provides a checklist reference for unit malfunction.

Appendix A: Product Specifications lists the instrument specifications.

Appendix B: Model Code Explanation describes the model code used to order the instrument.

Customer Support

Standard maintenance and repair services are available at various regional MKS Calibration and Service Centers. MKS also accepts the instruments of other manufacturers for recalibration using the Primary and Transfer Standard calibration equipment located at our regional service centers.

If any difficulties arise in the use of your Type 62xC/E2xC, or to obtain information about companion products MKS offers, contact any authorized MKS Calibration and Service Center. If it is necessary to return the instrument to MKS, please obtain an RMA Number (Return Material Authorization Number) from the MKS Calibration and Service Center before shipping. The RMA Number expedites handling and ensures proper servicing of your instrument.

Please refer to the inside of the back cover of this manual for a list of MKS Calibration and Service Centers.



Warning

All returns to MKS Instruments must be certified free of harmful, corrosive, radioactive, or toxic materials.

Chapter Two: Installation

How To Unpack the 62xC/E2xC

MKS has carefully packed the Type 62xC/E2xC so that it will reach you in perfect operating order. Upon receiving the unit, however, you should check for defects, cracks, broken connectors, etc., to be certain that damage has not occurred during shipment.

**Note**

Do *not* discard any packing materials until you have completed your inspection and are sure the unit arrived safely.

If you find any damage, notify your carrier and MKS immediately. If it is necessary to return the unit to MKS, obtain an RMA Number (Return Material Authorization Number) from the MKS Calibration and Service Center before shipping. Please refer to the inside of the back cover of this manual for a list of MKS Calibration and Service Centers.

**Caution**

Only qualified individuals should perform the installation and any user adjustments. They must comply with all the necessary ESD and handling precautions while installing and adjusting the instrument. Proper handling is essential when working with all highly sensitive precision electronic instruments.

Unpacking Checklist

Standard Equipment:

- Type 627C/E27C, 628C/E28C Unit
- Type 627C/E27C, 628C/E28C Instruction Manual (this book)

Optional Equipment:

- Electrical Connector Accessories Kit: 62xC/E2xC-K1 (includes a mate for the I/O connector)
- Most MKS Power Supply/Readouts
- Most MKS Pressure, Flow, Flow Ratio, and Throttling Valve Controllers
- RM-6 Rack Mount Kit, 19" rack accommodates 1 or 2 readouts and/or controllers
- Interface Cables (refer to Table 5, page 12, and Table 6, page 13)

Interface Cables

As of July 20, 2009, all products shipped to the European Community must comply with the EMC Directive 2004/108/EEC, which covers radio frequency emissions and immunity tests. In addition, as of January 1, 1997, some products shipped to the European Community must also comply with the Product Safety Directive 92/59/EEC and Low Voltage Directive 73/23/EEC, which cover general safety practices for design and workmanship. MKS products that meet these requirements are identified by application of the CE Mark.

To ensure compliance with EMC Directive 2004/108/EEC, an overall metal braided shielded cable, properly grounded at both ends, is required during use. No additional installation requirements are necessary to ensure compliance with Directives 92/59/EEC and 73/23/EEC.

**Note**

1. An overall metal braided, shielded cable, properly grounded at both ends, is required to meet CE Mark specifications.
2. To order an overall metal, braided, shielded cable, add an “S” after the cable type designation. For example, to order a standard connection cable to connect the 628C unit to a 651 controller, use part number CB259-5-10; for an overall metal braided, shielded cable use part number CB259S-5-10.

You can purchase interface cables to all MKS companion products from MKS (refer to Table 5), or you can make cables that meet the appropriate specifications. For cables connecting to non-MKS products, MKS can provide normal shielding or braided shielded cable assemblies in a nominal 10' (3 m) length, terminating in flying leads (pigtail) fashion at the opposite end.

Overall metal braided shielded cable assemblies, properly grounded at both ends, are recommended if the environment contains harsh EMI/RFI noise.

Table 5: MKS Interface Cables

	To Connect the 62xC/E2xC Unit to MKS Power Supply/ Readouts, Cables, and Pressure Controllers	Use the MKS Cable	
		Standard	Shielded
For 62xC/E2xC with 15-pin D-connector	Type 250 and 244	CB258-1-10	CB258S-1-10
	PR4000, Type 146 and 651	CB259-5-10	CB259S-5-10
For 62xC/E2xC with 9-pin D-connector	Type 250 and 244	CB629-4-10	CB629S-4-10
	CB259 cable	CB629-2-1	

Generic Shielded Cable Description

MKS offers a full line of cables for all MKS equipment. Should you choose to manufacture your own cables, follow the guidelines listed below:

1. The cable must have an overall metal *braided* shield, covering all wires. Neither aluminum foil nor spiral shielding will be as effective; using either may nullify regulatory compliance.
2. The connectors must have a metal case with direct contact to the cable shield on the whole circumference of the cable. The inductance of a flying lead or wire from the shield to the connector will seriously degrade the shield's effectiveness. Ground the shield to the connector before its internal wires exit.
3. With very few exceptions, the connector(s) must make good contact to the controller's case (ground). “Good contact” is about 0.01 ohms and the ground should surround all wires. Contact to ground at just one point may not suffice.
4. For shielded cables with flying leads at one or both ends; it is important to ground the shield at each such end *before* the wires exit. Make this ground with absolute minimum length. (A ¼-inch piece of #22 wire may be undesirably long since it has approximately 5 nH of inductance, equivalent to 31 ohms at 1000 MHz). After picking up the braid ground, keep wires and braid flat against the case. With very few exceptions, grounded metal covers are not required over terminal strips. If one is required, it will be stated in the Declaration of Conformity.
5. In selecting the appropriate type and wire size for cables, consider:
 - A. Voltage ratings.
 - B. Cumulative I^2R heating of all the conductors (keep them safely cool).
 - C. IR drop of the conductors, so that adequate power or signal voltage gets to the controller.

- D. Capacitance and inductance of cables that handle fast signals (such as data lines or stepper motor drive cables).
- E. Some cables may need internal shielding from specific wires to others.

Ethernet Communication Connector

The Ethernet communication connector is:

- Ethernet crossover cable with standard RJ-45 connectors

Or:

- Two straight Ethernet cables and an Ethernet switch or Hub.



Note An Ethernet cable properly shielded at both ends is required to meet CE Mark specifications.

Table 6: Suggested Ethernet Communication Connectors

	Shielded	Unshielded
Cross-over Cables	L-COM TRD855XCR-5	L-COM TRD45CRR-5
Straight Cables	L-COM TRD855SCR-5	

Product Location and Requirements

Table 7: Ambient Operating Temperature

Product	Ambient Operating Temperature Range
627C/E27C	15° to 40° C
628C/E28C	15° to 50° C

Table 8: Power Requirements

Product	Power Supply Configuration: Minimum Current Required (A)	
	±15V (±5%)	+24V (±10%)
627C/E27C	0.40	0.60
628C/E28C	0.70	0.90

Noise and ripple should be less than 20mV peak to peak.

Output Readout

You may use any readout that has input capabilities of less than 0 to greater than 10 VDC and impedance greater than 10K ohms.

For additional product requirements, refer to *Appendix A: Product Specifications*, page 49.

Setup

Dimensions



Note All dimensions are listed in inches with millimeters referenced in parentheses. The tolerances for the dimensions are ± 0.1 inches (X.X) and ± 0.02 inches (X.XX).

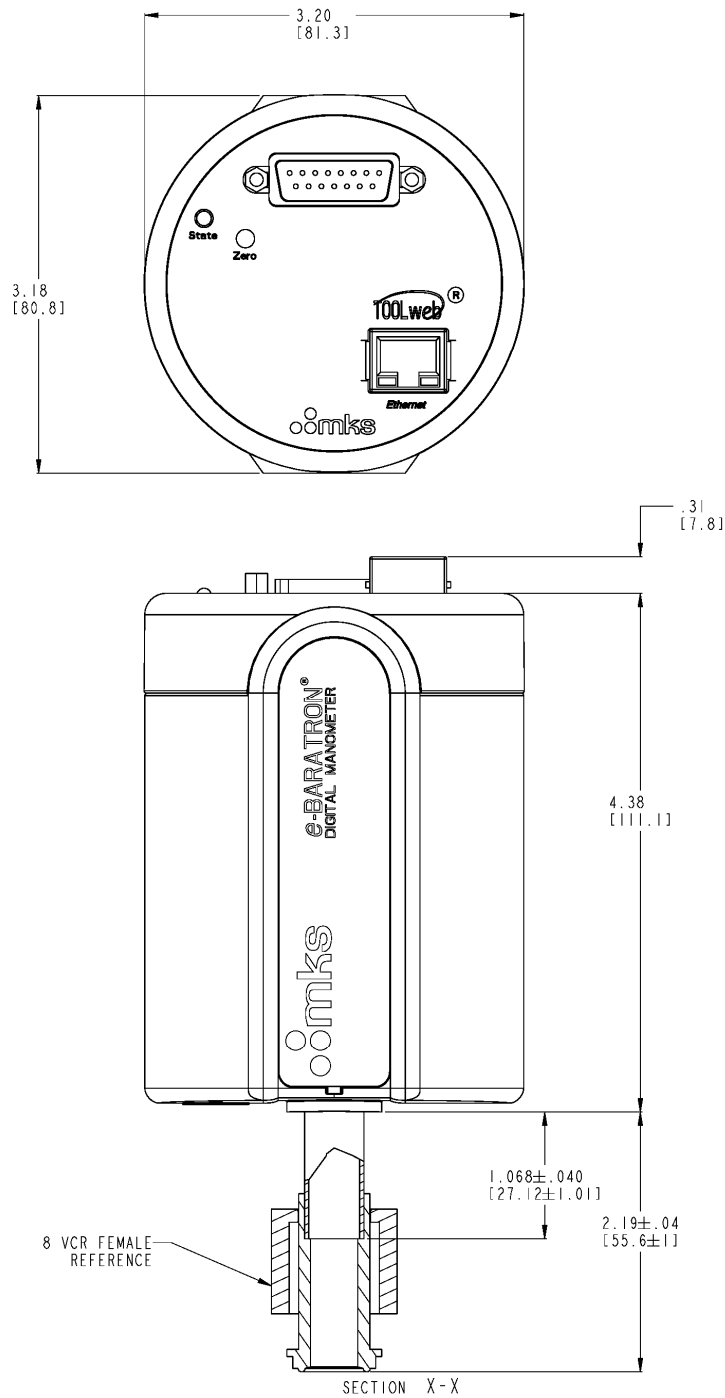

Figure 1: 62xC/E2xC Dimensions

Label

Each 62xC/E2xC unit has one serial number label mounted on the back surface. The label shows the serial number, the model code, and mounting orientation.



Figure 2: Serial Number Label

Fittings

The 62xC/E2xC manometer is available with the following fittings:

- ½” outside diameter (12.7 mm) tubulation
- Swagelok® 8-VCR® (female)
- Swagelok 8-VCR (male)
- Mini-CF (rotatable)
- NW-16-KF
- NW-25-KF
- Swagelok 8-VCO (female)

Mounting Instructions

Mount the manometer with the inlet port pointing (vertically) downward. The manometer port will easily carry the weight of the manometer. Although the unit can be mounted in any orientation, mounting it as suggested allows any foreign matter entering the pressure port to fall away from the diaphragm.

Isolate the unit from vibration as much as possible. When not subject to gas damping at low pressure, the diaphragm may become susceptible to resonance. The low range manometers (≤ 1 Torr) are very sensitive and you should isolate them from any vibration that exists. Remember to isolate the vibration through the cables as well as through the port.

It is also recommended that if your process takes less than 60 minutes (1 hour) to complete, you should mount an isolation valve between the process chamber and the capacitance manometer—particularly for full-scale pressure ranges below 10 Torr. This will minimize shifting of the manometer’s output due to temperature variations of the sensor when exposed to atmospheric or higher-pressure conditions.

Electrical Information



Note

The ground of any external power supply and readout should be the same as the manometer ground (chassis ground) to minimize any possible ground loops that can affect the performance and stability of the system.

62xC Power Supply Ground Configuration

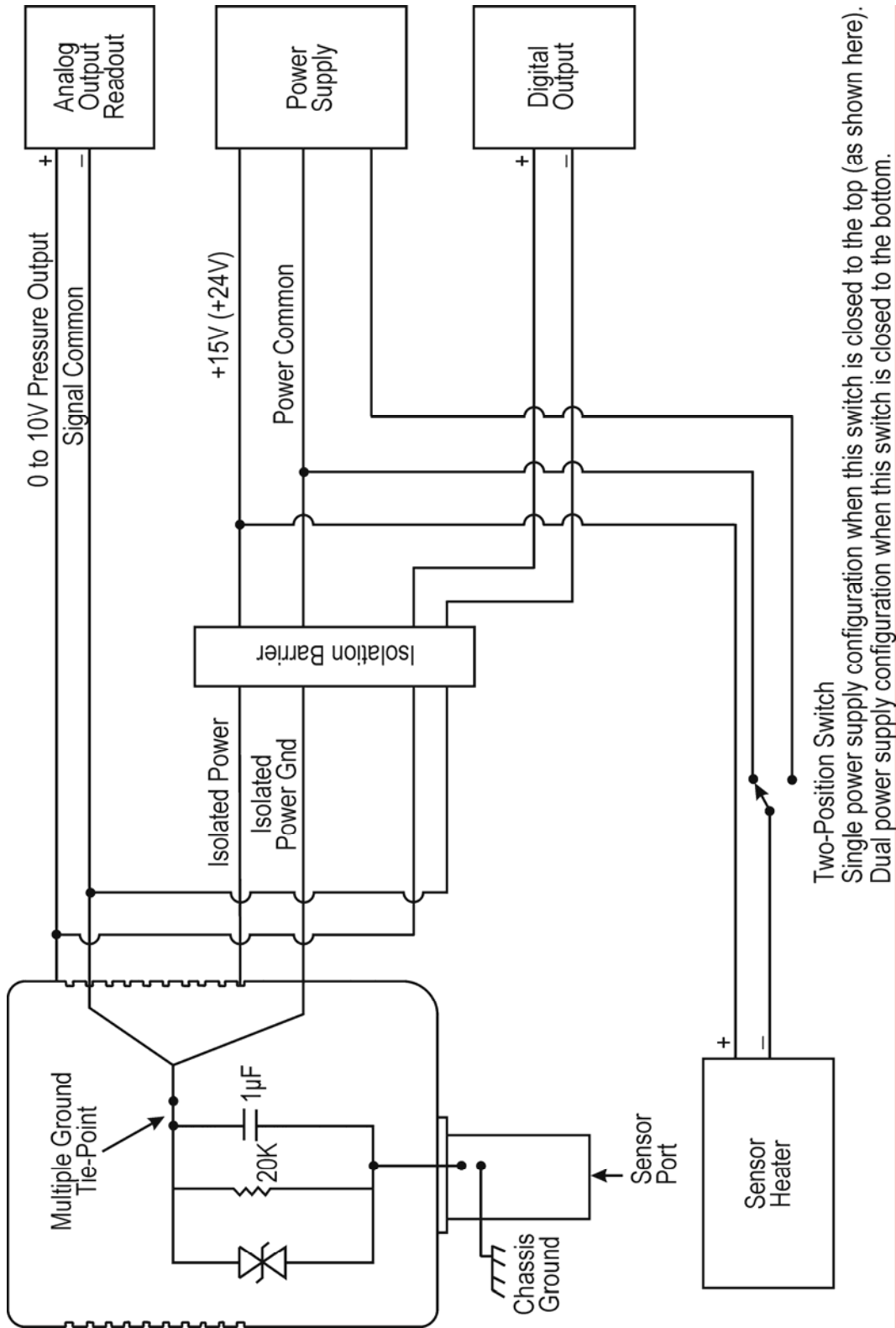

Figure 3: 62xC Power Supply Ground Configuration

Table 9: 15-Pin Interface Connector Pin Assignments

Pin	Assignment
1	Reserved
2	Pressure Signal Output
3	Reserved
4	Reserved
5	Power Return (Power Common)
6	-15 VDC
7	+15 VDC or +24 VDC
8	Reserved
9	Reserved
10	Reserved
11	+15 VDC or +24 VDC
12	Pressure Signal Output Return (Signal Common)
13	Reserved
14	Reserved
15	Chassis Ground

Table 10: 9-Pin Interface Connector Pin Assignments

Pin	Assignment
1	Pressure Signal Output
2	Reserved
3	Reserved
4	+15 VDC or +24 VDC
5	-15 VDC
6	Reserved
7	Reserved
8	Pressure Signal Output Return (Signal Common)
9	Power Return (Power Common)

**Note**

The “Reserved” pin assignment refers to a pin with an internal connection that may be assigned a function in the future. The “No Connection” pin assignment refers to a pin with no internal connection. Pin 7 and Pin 11 have the same connection. Either pin may be used to connect to the positive rail of the power supply.

Startup

Power-Up

At power-up, the 62xC/E2xC manometer performs internal communications link checks and internal diagnostics checks. The results of these checks are indicated by the colors green, amber, and red of the status LED located on the top panel of the device. Refer to *Status LED*, page 22, for details of LED status indications.

When power is applied to the device, the following LED sequence occurs:

1. The LED starts to blink red for approximately 3 seconds and then turns to blinking green.
2. After the unit has reached its operating temperature, the LED will turn to solid green. If power is interrupted at any time after the LED has turned to solid green, LED will blink green for a minimum of 5 minutes or until the control temperature is reached again.

**Note**

Even though the LED has turned solid green, the manometer must be allowed to warm up fully as described below in *Warm Up Time* to achieve guaranteed performance within specification.

Zero Adjustment

All process manometers require initial and periodic zero adjustments. Prior to initial operation and during periodic maintenance you must check the manometer zero to verify the proper output. Refer to *Adjusting the Analog and Digital Zero*, page 42, for more information.

Warm Up Time

Allow sufficient time for the manometer to warm up. The warm up times for 23° C ambient temperature conditions are:

- 2 hours for ≥ 1 Torr units
- 4 hours for < 1 Torr units

If the ambient temperature is lower than 23° C, the warm up time may be longer than shown above.

**Note**

The transducer must be *fully stabilized* before you make any zero adjustments.

Suggested Pressures for Reading and Control

Table 11 lists the lowest suggested pressures for reading and control with the 62xC/E2xC manometer.

Table 11: Lowest Suggested Pressures for Reading and Control

Full Scale Range (Torr)	Lowest Suggested Pressure for Reading (Torr)	Lowest Suggested Pressure for Control (Torr)
0.1	5×10^{-5}	5×10^{-4}
1	5×10^{-4}	5×10^{-3}
10	5×10^{-3}	5×10^{-2}
100	5×10^{-2}	5×10^{-1}
1000	5×10^{-1}	5×10^0

Lowest Suggested Pressures Available for Reading

The pressures listed in the middle column of Table 11 reflect reliable and practical pressures for different range manometers. Lower readings may be obtained in environments that have stable temperature and air flow. Temperature controlled manometers can obtain repeatable pressure measurements down to 1×10^{-5} Torr.

Lowest Suggested Pressures to Use for Control with Analog Output

The pressures listed in the last column of Table 11 are for reference and represent the pressure reading of the manometer at 50 mV signal output. A DC signal of at least 50 mV is the recommended minimum signal level to use when integrating any manometer into complex processing systems.

This page intentionally left blank.

Chapter Three: Overview

General Information

The 62xC/E2xC manometer contains an analog interface as well as a digital interface. The analog interface produces a 0 to 10V signal proportional to the input pressure. The digital interface is Ethernet-based with a graphical user interface that resides within the device. An important advantage of the Ethernet interface is the ability to monitor pressure remotely as well as conduct diagnostics using a standard PC.

In addition, the 62xC/E2xC Ethernet interface is TOOLweb[®] ready. The TOOLweb ToolSide Protocol provides an open, XML-based interface between a server (sensor/instrument) and the client application (i.e., a BlueBox). Refer to Version 1.1 of the TOOLweb ToolSide Protocol document for a complete description.

The two major functional parts of the 62xC/E2xC manometer are the sensor and signal conditioner.

Sensor

The 62xC/E2xC manometer contains an absolute capacitance-based pressure sensor. This sensor utilizes a single-sided, dual-electrode/AC bridge circuit design. In this design, two capacitance electrodes are deposited upon a ceramic disc in a concentric “bull’s-eye” arrangement. The disc is positioned close to an Inconel[®] tensioned diaphragm to form two capacitors in an AC bridge circuit. The other side of the diaphragm is exposed to the process gas.

The diaphragm deflects with changing pressure—force per unit area—independent of the composition of the measured gas. This deflection causes a capacitance change between the diaphragm and the adjacent electrode assembly. When pressure is equal on both sides of the diaphragm, the bridge is balanced. As pressure deflects the diaphragm toward the electrode, the center capacitance changes more than the outer capacitance, causing the bridge to become unbalanced and an AC voltage to be generated. The output signal, which is proportional to pressure, can be provided as an analog signal (0 to 10 V) through the 9 or 15 pin D-sub connector and, as a digital signal, obtained through the Ethernet communication on the RJ45 type connector. The thermal enclosure reduces the effects of ambient temperature changes.

The zero and span stability are increased in the 627C/E27C (45° C) and 628C/E28C (100° C) manometers by using a temperature controlled environment for the sensor and front-end electronics.

Signal Conditioner/Electronics

The signal conditioner contains state-of-the-art, low impedance balanced bridge circuitry, self-compensated for thermal stability with ambient temperature changes. The output is a DC voltage that is digitally linearized to produce both analog and digital outputs.

Power Supply

The 62xC/E2xC manometer power supply requirements are specified under *Electrical Specifications*, page 49. The power is introduced to the manometer through the D-subminiature electrical connector on the top of the unit.

Pressure Measurement

For digital (Ethernet Interface) output, the pressure value depends on a number of variables, many of which are user-adjustable through software commands. Figure 4, page 23, illustrates how actual pressure values are generated from the raw sensor output.

Pressure readings (both analog and digital) can be zeroed by using the One-Touch Zero Push Button located on top of the manometer or by sending the command through the Ethernet graphical user interface. Both readings are getting automatically corrected for any zero shifts occurred. Then pressure readings are linearized and converted either into 0 to 10 V analog signal or to a digital output expressed in the user-selected units of pressure.

If necessary, an additional zero offset can be applied digitally to the corrected pressure value, before the value is converted to the selected units. Refer to *Adjusting the Analog and Digital Zero*, page 42, for more details.

Top Panel Components

Figure 1, page 14, shows the top panel of your 62xC/E2xC manometer.

Ethernet Communications Connector

The 62xC/E2xC has an Ethernet port that can be accessed via an RJ-45 connector. Either a CAT-5 crossover cable or two straight Ethernet cables and a multi-port hub are required to communicate to the 62xC/E2xC using a standard PC.

One-Touch Zero Push Button

This push button provides manual zeroing capability for the manometer's pressure reading. The push button affects both the analog and digital outputs. Refer to *Adjusting the Analog and Digital Zero*, page 42, for more information.

Analog Interface Connector

The 9-pin or 15-pin male Type D-sub interface connector provides the pressure output signal for direct measurement from the 62xC/E2xC manometer. Refer to Table 9, page 17, for the connector pinout.

Status LED

Table 12: Status LED

Status of LED	Meaning of the Status
Blinking Amber	Unit powered and in process of initializing
Blinking Green	Unit is warming up
Solid Green	Unit has reached control temperature (see <i>Warm Up Time</i> , page 18)
Solid Amber	Alarm of a fault condition
Solid Red	Power supply out of spec or heater control failure
Momentarily Amber	Zero operation attempted while device is out of range.

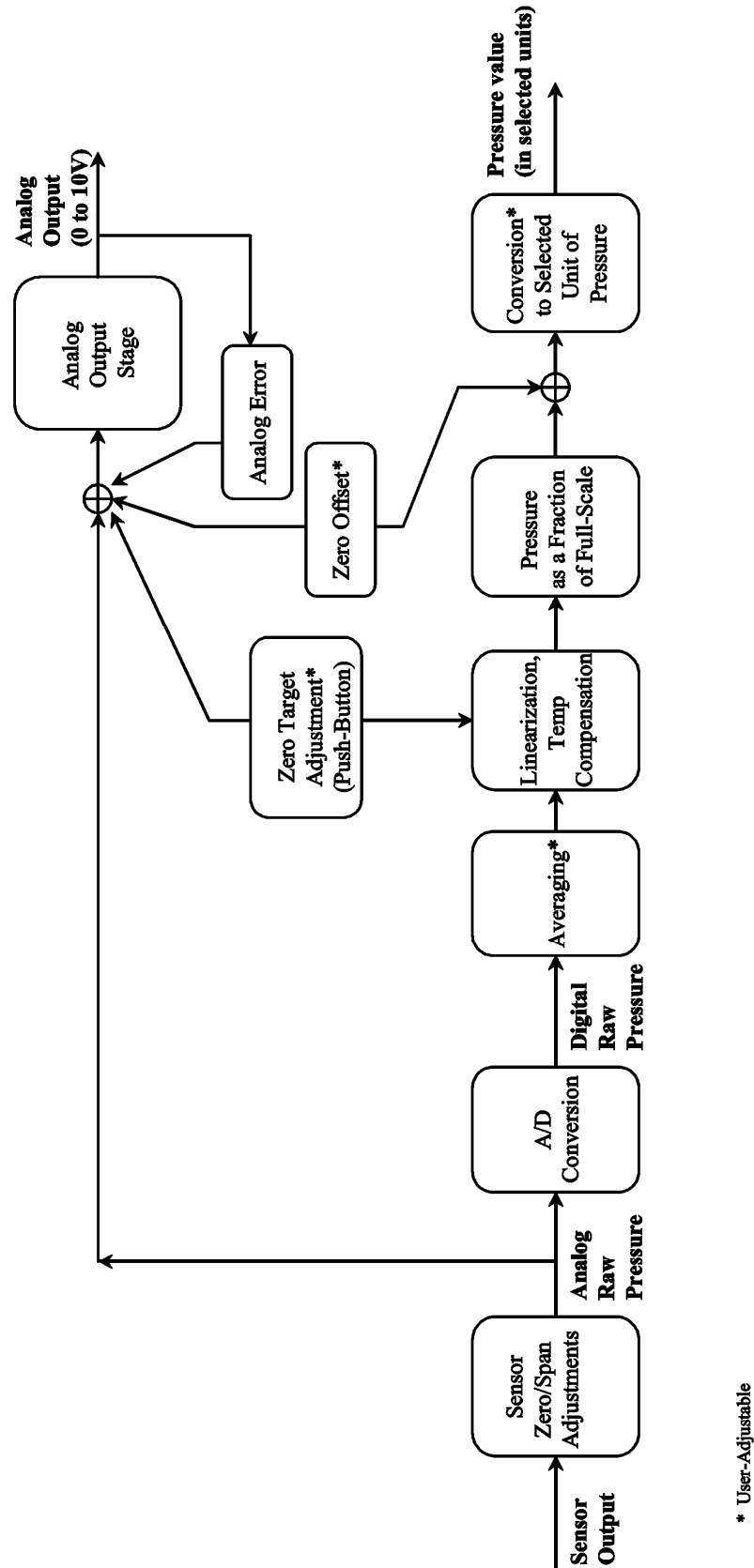

Figure 4: Analog and Digital Pressure Calculation (Patented)

This page intentionally left blank.

Chapter Four: Operation of Ethernet Interface

The Ethernet interface on the 62xC/E2xC provides a graphical user interface and is TOOLweb ready. The 62xC/E2xC has an Ethernet port that can be accessed via an RJ-45 connector. Either a CAT-5 crossover cable or two straight Ethernet cables and a multi-port hub are required to communicate to the 62xC/E2xC using a Windows®-based PC.

The PC must have an Internet Explorer v6.0 or later with Sun™ Microsystems Java® RunTime Environment version 1.5.0_02 or later running on it. Java RunTime Environment may be downloaded from the software download site of the website www.Java.com.

MAC IDs and IP Address

Each unit will have a unique MAC ID, set by the factory. This is displayed on the Configuration/Network Settings page of the device Web browser. See page 35 for details.

Each unit will be shipped from the factory with a default IP address of 192.168.1.100 and is re-settable by the user through the Web browser. It is strongly recommended that the user re-assign a unique IP address to the device before installing it in a network. Multiple IP addresses on the same network will cause communication problems.

Follow the procedure outlined in *Establishing an Ethernet Connection*, Step 3 (Case 2), Step 4, and Step 5 on page 26.

Resetting the IP Address

If the IP address of the device is unknown to the user, the following procedure should be followed to reset the IP address to the default factory setting of 192.168.1.100.

Recycle power to the device. After the status LED begins to flash green, press the Zero Push-button and hold for 10 sec. This must be done within 60 seconds after the device is powered. This will assign the default network settings (shown below) in the device. For the new network settings to take affect, the device must be power-cycled once more.



Caution If IP address resetting has been performed on more than one unit in a network, multiple units will have the same IP address and will cause communications problems. In order to avoid this, after resetting, user may assign a unique IP address to the device through the Web browser.

Follow the procedure outlined below, *Establishing an Ethernet Connection*, page 26, in order to communicate to the device. Now the user may change the IP address through the Web browser, if needed.

Assigning a New IP Address

Web Page Monitor Privileges

A password is not required for monitor privileges of the Ethernet Web pages. The user may log in by typing the appropriate URL code in the format described below. Example shown below is for the factory default IP address.

`http://192.168.1.100/index.html` or `http://192.168.1.100/`

Connecting to the 600C Using the Ethernet Interface

This procedure covers two general areas:

1. Establishing an Ethernet connection (configure your computer).
2. Functional Description of each of the Web pages.

Establishing an Ethernet Connection

- An Ethernet crossover cable with standard RJ-45 connectors. Connect one end to the Ethernet port on the device and the other end to the Ethernet port on the host computer.

Or:

- Two straight Ethernet cables and a multi-port switch hub. Connect one end to the Ethernet port on the device and the other end to one of the ports on the switch. The second cable should be connected between a second port on the switch and the Ethernet port on the host computer.

1. Apply power to the 62xC/E2xC via 24 VDC-power supply or ± 15 V power supply.
2. Establish a physical connection. To do so, connect the Ethernet cable between the 62xC/E2xC and your PC as described above.
3. Configure your PC for fixed IP address networking. This step description is based on Windows 2000, but other Windows versions will be similar. To complete this step:
 - a. Right-click on My Network Places and select Properties.
 - b. Right-click on Local Area connection and select Properties again.
 - c. Select Internet Protocol (TCP/IP) and click Properties.
 - d. Indicate that you will specify a fixed IP address (“Use the following IP address”).

Case 1: IP address of the device is known to the user.

Configure the PC to the following network settings. (The example given below is for a device with IP address of 10.150.31.xxx, where xxx is a 1 to 3 digit number that is assigned to the device.)

IP address:	10.150.31.200 (format: aaa.bbb.ccc.xxx)
Subnet Mask:	255.255.255.0 (format: aaa.bbb.ccc.0)
Default Gateway:	10.150.31.1 (format: aaa.bbb.ccc.1)
Primary DNS:	<blank> Not Used

Then, select OK.

Case 2: IP address has been reset using the Zero push-button (refer to ‘Resetting the IP Address’, on page 25) or device has been just received from the factory with the default IP address of 192.168.1.100.

Configure the PC to the following network settings:

IP address:	192.168.1.200
Subnet Mask:	255.255.255.0
Default Gateway:	192.168.1.101
Primary DNS:	<blank> Not Used

Then, select OK.

- e. Click on OK on all configuration screens.

Your computer is now configured properly to connect with the 600C.

4. Connect to the 62xC/E2xC using Internet Explorer. To do so:
 - a. Open Internet Explorer.
 - b. In the URL address bar, type in the IP address of the 600C. This is 192.168.1.100 if the IP address has been reset using the push-button or if the device has been received from the factory with the default IP address.

Then, press the Enter key. The Device page should appear, as shown in Figure 5, page 29.

5. Change the IP address of the device if current IP address is the factory default of 192.168.1.100. To do so hit the Configuration tab and hit the Network Settings button. This page will allow the user to change the TCP/IP configuration, including the IP address of the device.



Caution Other applications running on the PC may interfere with the real time capability of the 62xC Web page.

Description of Web Pages

General Information

The Web pages for the MKS e-Baratron® Type 62xC/E2xC contain four main pages and several sub-pages.

Device information such as the MKS model number and serial number of the product and current date are displayed at the bottom of every page.

On the left side of every page on the white space (except the Device page), following information are displayed and are updated dynamically:

- Messages such as the device's readiness, any alarms or warnings etc.
- Total power on time
- Current pressure in the selected unit of pressure

**Note**

The user's PC or laptop must have Internet Explorer v6.0 or later with Sun™ Microsystems Java® RunTime Environment version 1.5.0_02 or later running on it. Java RunTime Environment may be downloaded from the software download site of the Web site, www.Java.com.

Detailed features of each Web pages are as described in the following pages.

Device Page

The Device page:

- Displays the current pressure read by the 62xC/E2xC manometer.
- Displays warnings or alarms, if there are any. Click the Events button to view the details of the alarms.
- Allows the user to set the units of measurement. Select the desired units from the drop-down menu and click the Set button.

The Device page has two branches: the Events page and the Information page. Click on either button to go to the respective page.

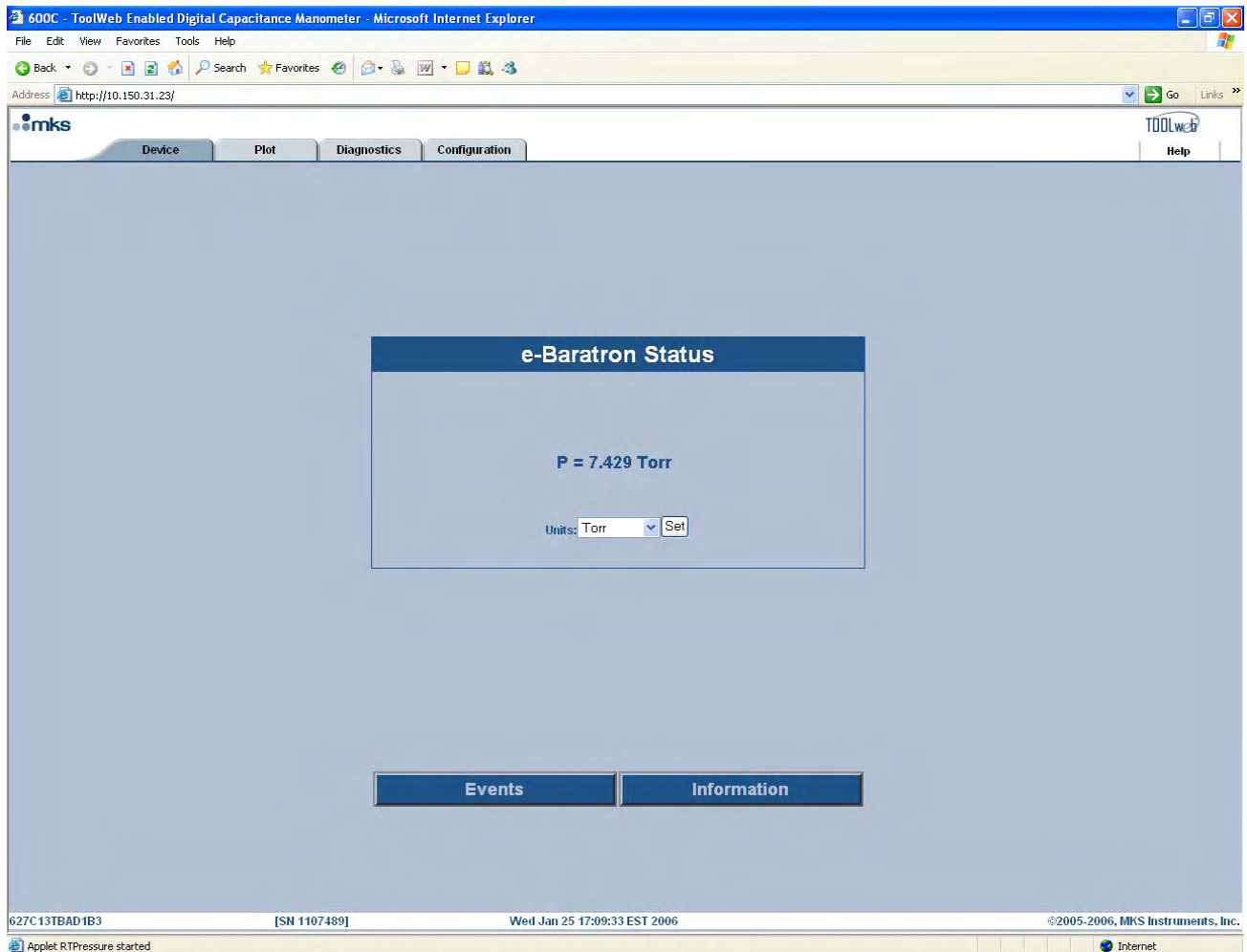

Figure 5: Device Page

Device/Events Page

e-Baratron Time (Current Device Time) is the total duration that the power was on the device since shipped from the factory.

e-Baratron Events displays all the alarm events and allows the user to clear the event display.

Click on the 'Clear Events' button to clear the events logged.

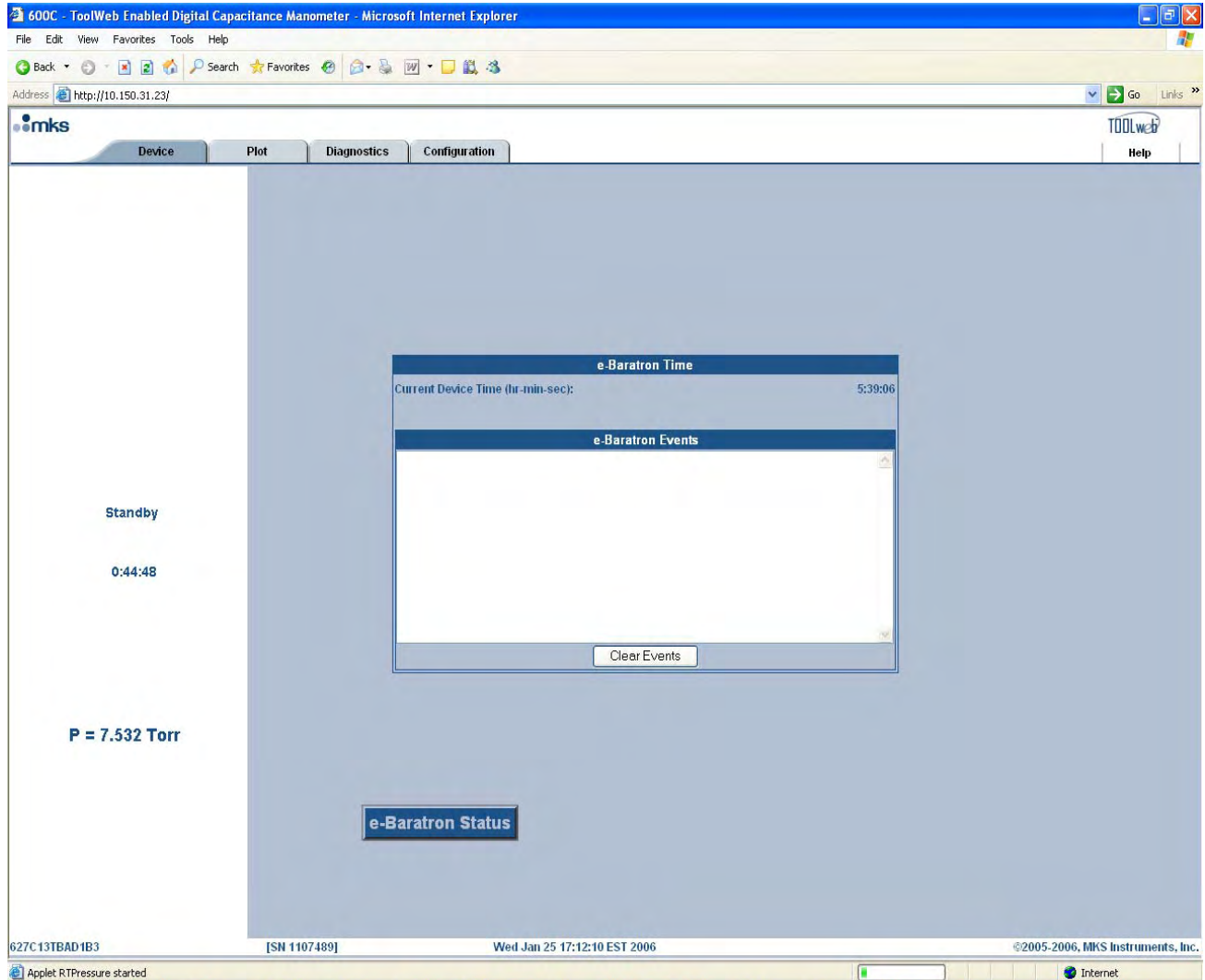

Figure 6: Device/Events Page

Device/Information Page

The Device/Information page provides the model number, serial number, full scale pressure range, and software versions used in the device.

600C - ToolWeb Enabled Digital Capacitance Manometer - Microsoft Internet Explorer

Address: http://10.150.31.23/

mks TOOLweb Help

Device Plot Diagnostics Configuration

Standby

0:44:35

P = 7.564 Torr

e-Baratron Information

Model No.:	627C13TBAD1B3
Serial No.:	1107489
Full-Scale Range (Torr):	1000
Communications SW Version:	0.0
Signal SW Version:	0.0

e-Baratron Status

627C13TBAD1B3 [SN 1107489] Wed Jan 25 17:22 EST 2006 ©2005-2006, MKS Instruments, Inc.

Applet RTPressure started Internet

Figure 7: Device/Information Page

Plot Page

The user may monitor the pressure output dynamically using the Plot page.

Digital and Analog current pressure is displayed in the units selected from the Device page.

Sample rate (ms): Default value for sampling rate is 1000 ms. Type in the desired sampling rate, as low as 100 ms, in increments of 100 ms.

User may select to monitor both Analog and Digital outputs or may select either one individually.

Scaling of the vertical axis is done automatically, by default.

Manual Scale: User may set the scaling of the vertical axis. To do this check of the 'manual scale' cell, set the Y min and Ymax and click the 'Set' button.

'Pause' and 'Clear' buttons allows the user to pause and clear the data displayed on the screen.

'Select Logfile' allows the user to log the data on to a file. In addition, the icons displayed on the top of the screen allow zooming in etc. Hitting the 'Close Window' button returns to the previous page opened.

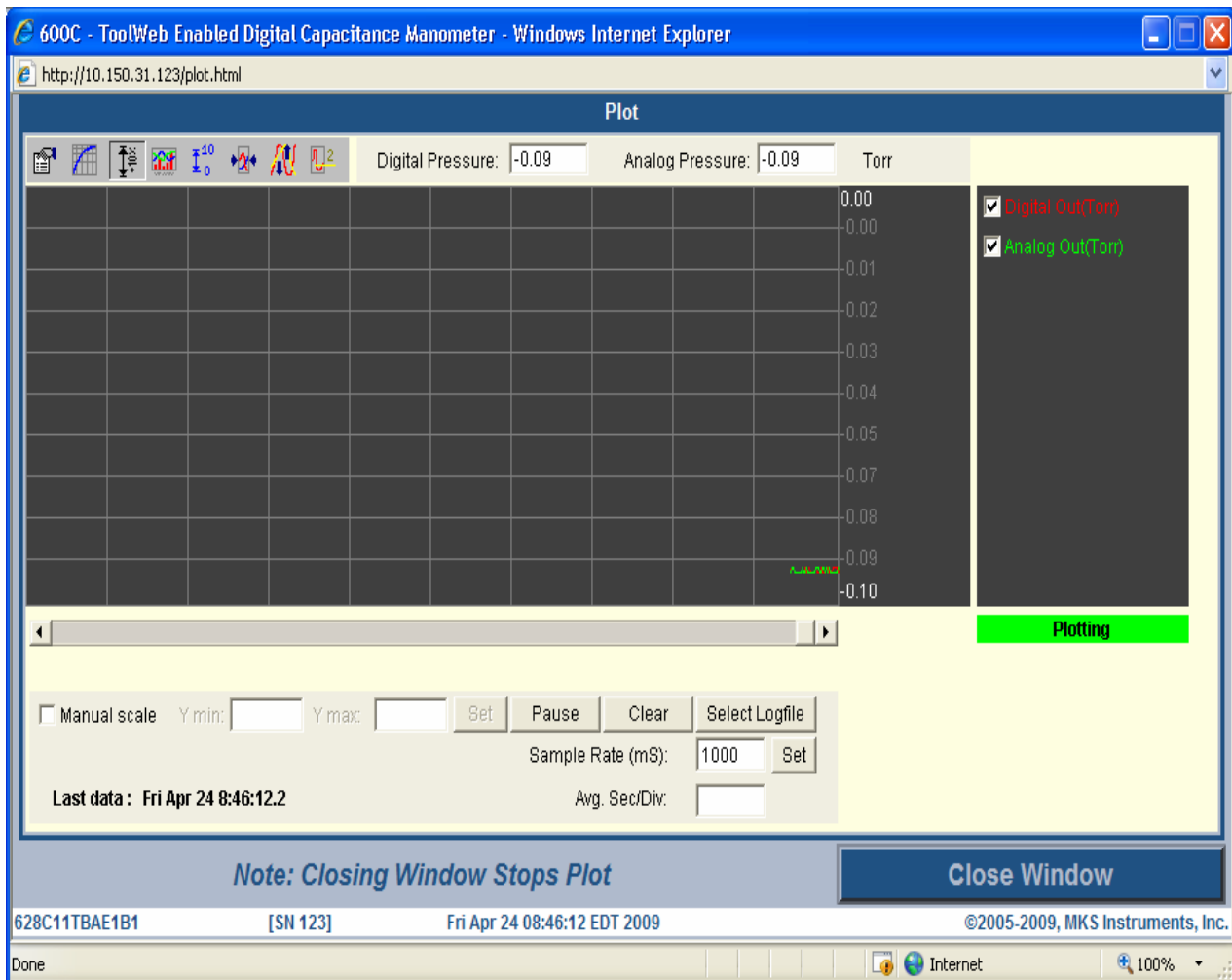

Figure 8: Plot Page

Diagnostics Page

The Diagnostics page provides the following diagnostics information and capabilities:

- **Device Time:** Cumulative time that the device had power on since leaving the factory. This is not re-settable by the user.
- **Cumulative Drift:** Total drift that the unit had since leaving the factory. This is not re-settable by the user.
- **Over-Range Times:** Total number of times that the device was exposed to greater than 110% of full-scale pressure.
- **Diaphragm Shorted Times:** Number of times that the unit was exposed to diaphragm-shortening pressure.
- **'Pressure Max' and 'Pressure Min':** Displays the maximum and minimum pressure and corresponding Device Time that the device measured since the last time 'Reset MinMax' button was pressed.
- **'Reset MinMax' Button:** Resets the maximum and minimum values of the pressure. This capability can be used to spot pressure variations, spikes, and similar transient pressure events.
- **Press to Refresh Diagnostic Display Button:** Refreshes all the values displayed above with latest information.

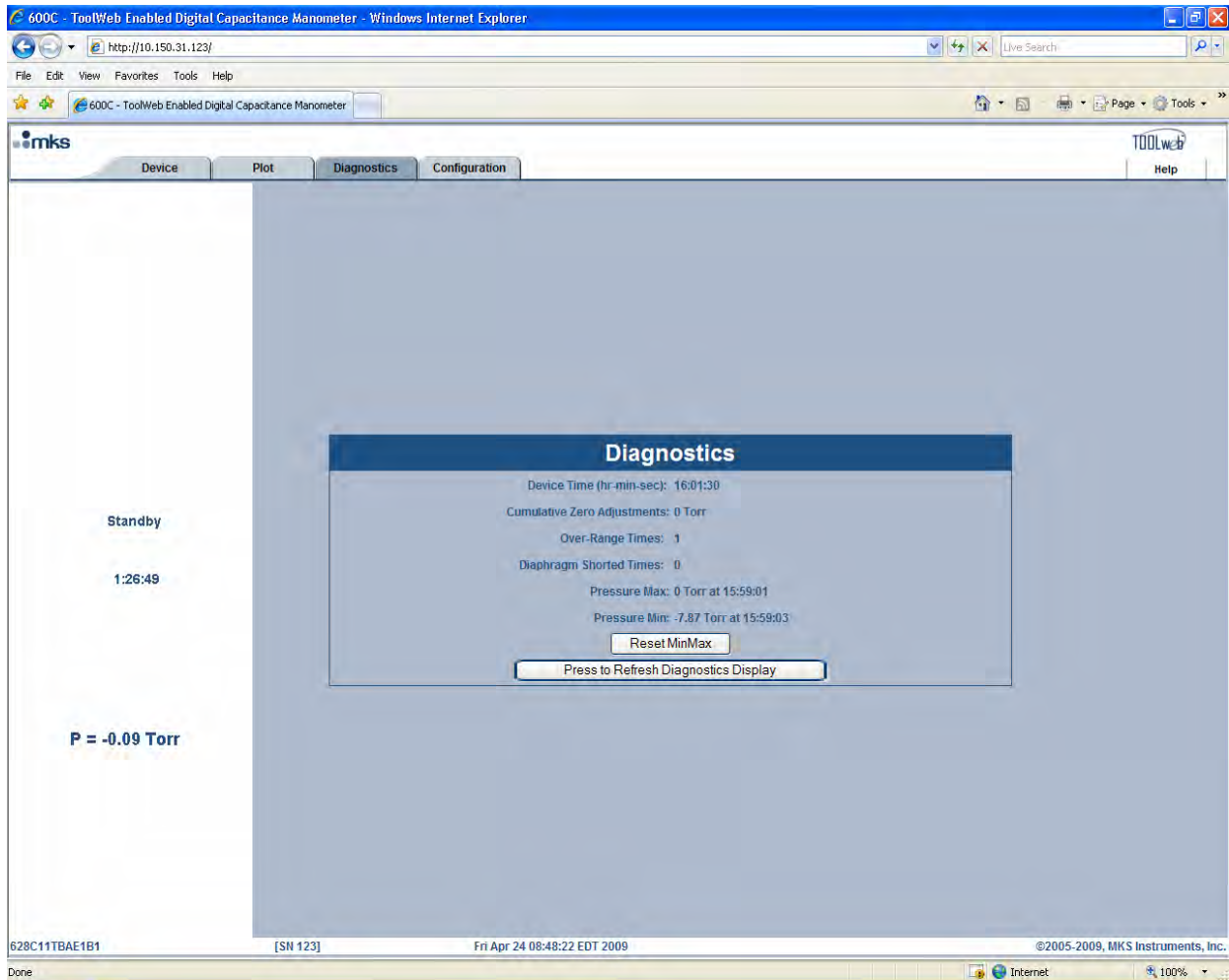

Figure 9: Diagnostics Page

Configuration Page

The Configuration page has four sub pages: Network Settings, Limit Settings, Zero Adjustment and Display Setup. The user may click on appropriate buttons to access the corresponding page.

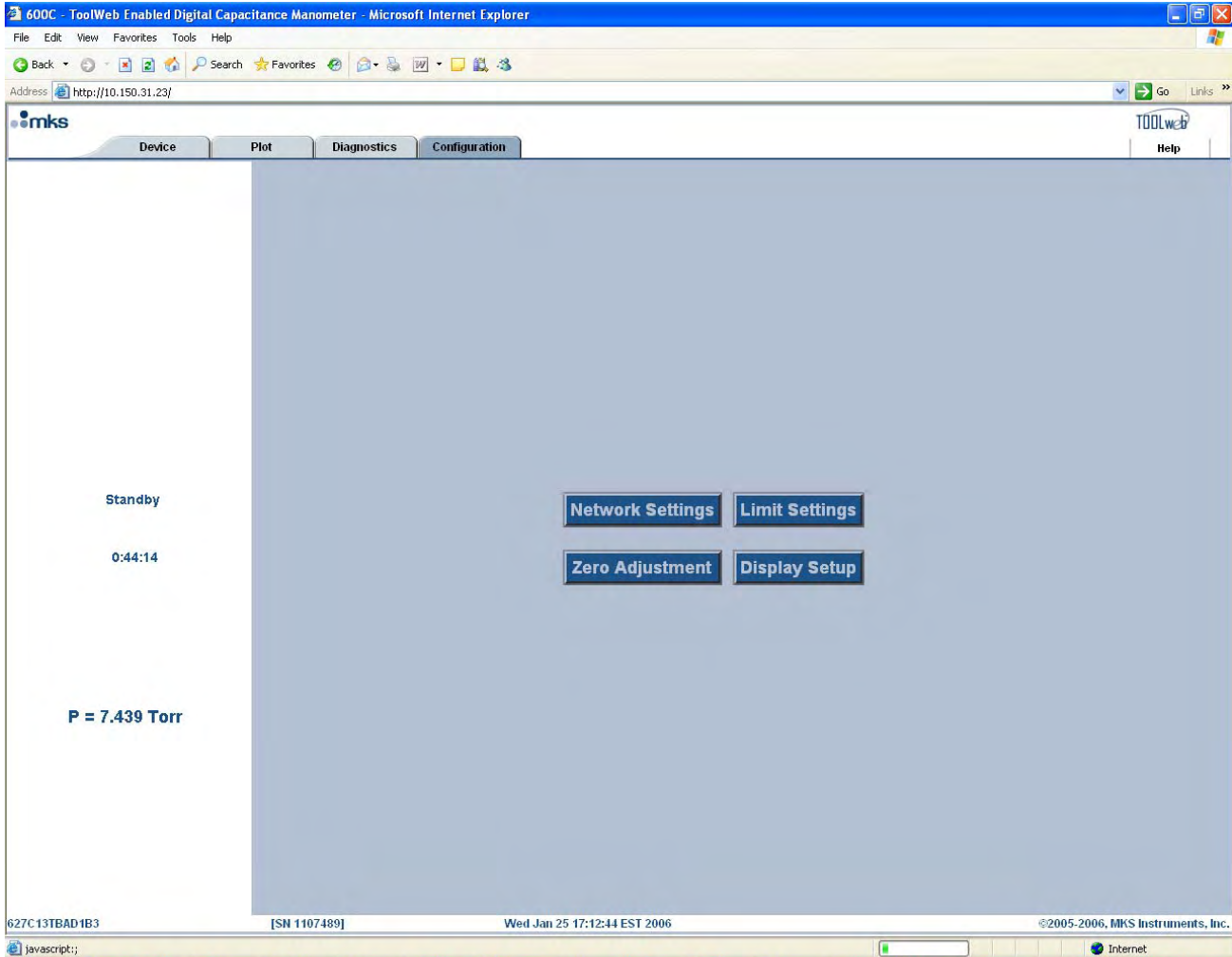

Figure 10: Configuration Page

Configuration/ Network Settings Page

User may change the network settings (TCP/IP configuration) as described on page 26, *Connecting to the 600C Using the Ethernet Interface*.

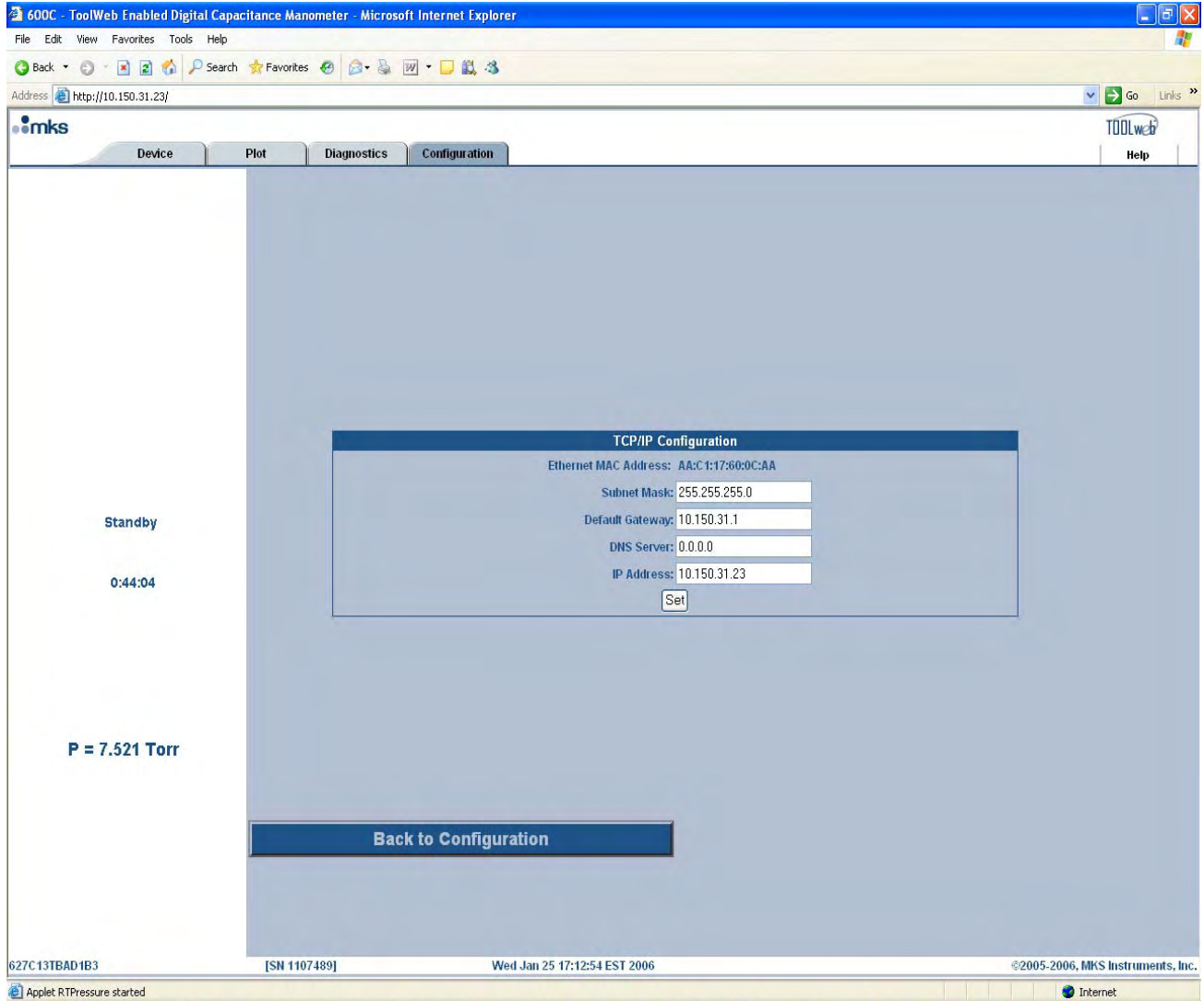

Figure 11: Configuration/Network Settings Page

Configuration/ Limit Settings Page

Through the Limit Setting, the user may select and set an upper and lower limit for pressure that would trigger an Alarm when the limits are crossed. LED will turn to amber when an alarm is triggered.

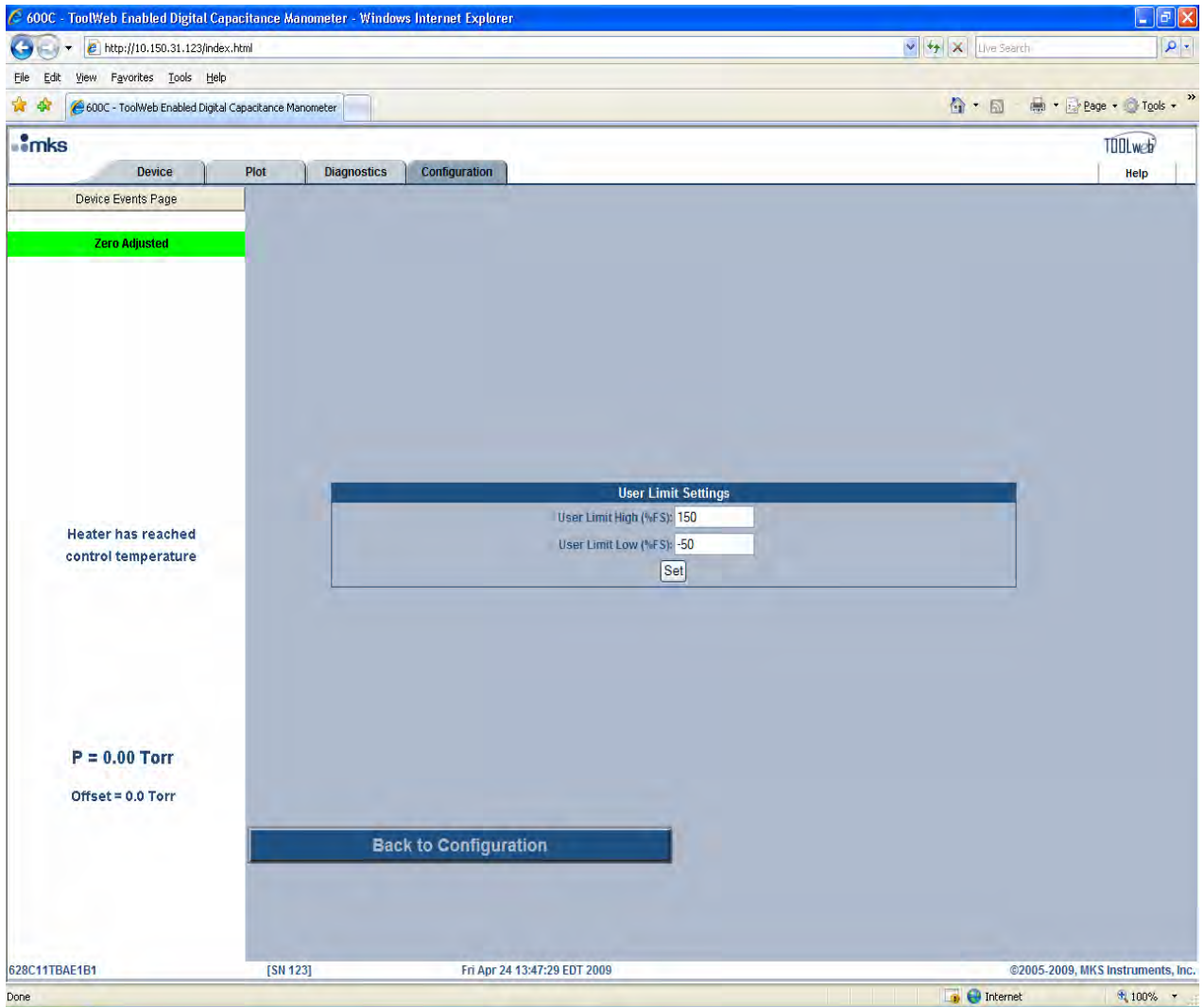

Figure 12: Configuration/ Limit Setting Page

Configuration/ Zero Adjustment Page

MKS e-Baratron® Type 62xC/E2xC allows three modes of zero adjustments. Refer to *Zero Adjustments Modes*, page 43, for details.



Caution The manometer must be allowed to warm up fully as described in *Warm Up Time* on page 18 to achieve guaranteed performance within specification.

Zero adjustment modes are activated only after following two conditions are met:

- 1. Device reaching control temperature.**
 - 2. 5 minute internal timer has times out after a power cycle is done.**
-

Three modes of zero adjustment options are available to the user. The three options are Zero Adjust, Zero Offset and Zero Target.

Follow the procedure described below to perform any one of the three modes of zero adjustments. Refer to *Zero Adjustments Modes*, page 43, for details.

Mode 1 – Push-button Zero with No Offset

From the pull-down menu on the Zero Adjustment page select ‘Zero Adjust’ from the pull-down menu and press the ‘Set’ button. Press the ‘Zero’ button..

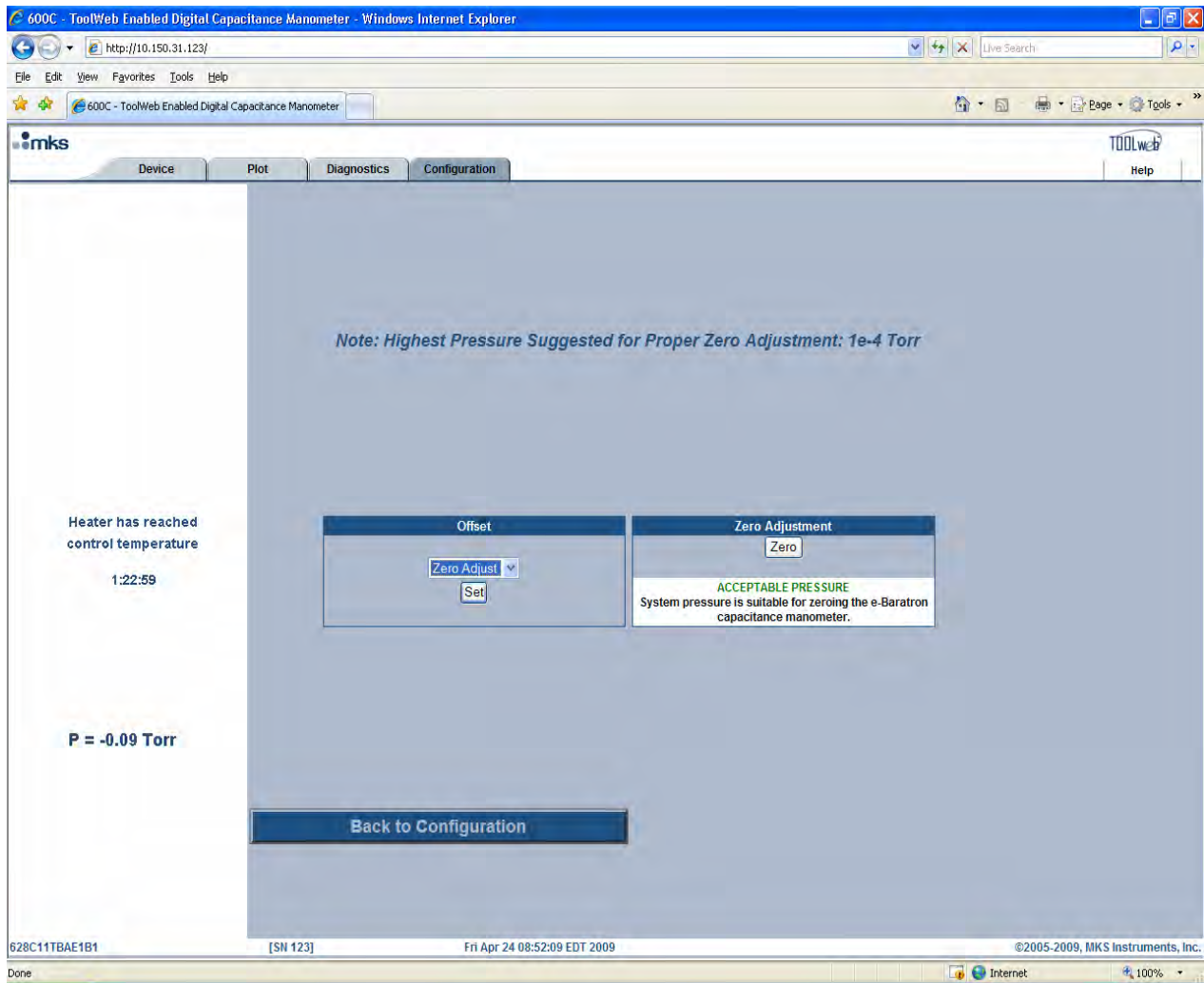

Figure 13: Configuration/ Zero Adjustment with ‘Zero Adjust’ Option

Mode 2 – Push-button Zero with Offset = $x \% FS$

From the pull-down menu on the Zero Adjustment page select ‘Zero Offset’ from the pull-down menu and press the ‘Set’ button.

This will bring up the two cells that need to be filled out. Fill out the cells with appropriate values, press the ‘Set’ button and then the ‘Zero’ button.

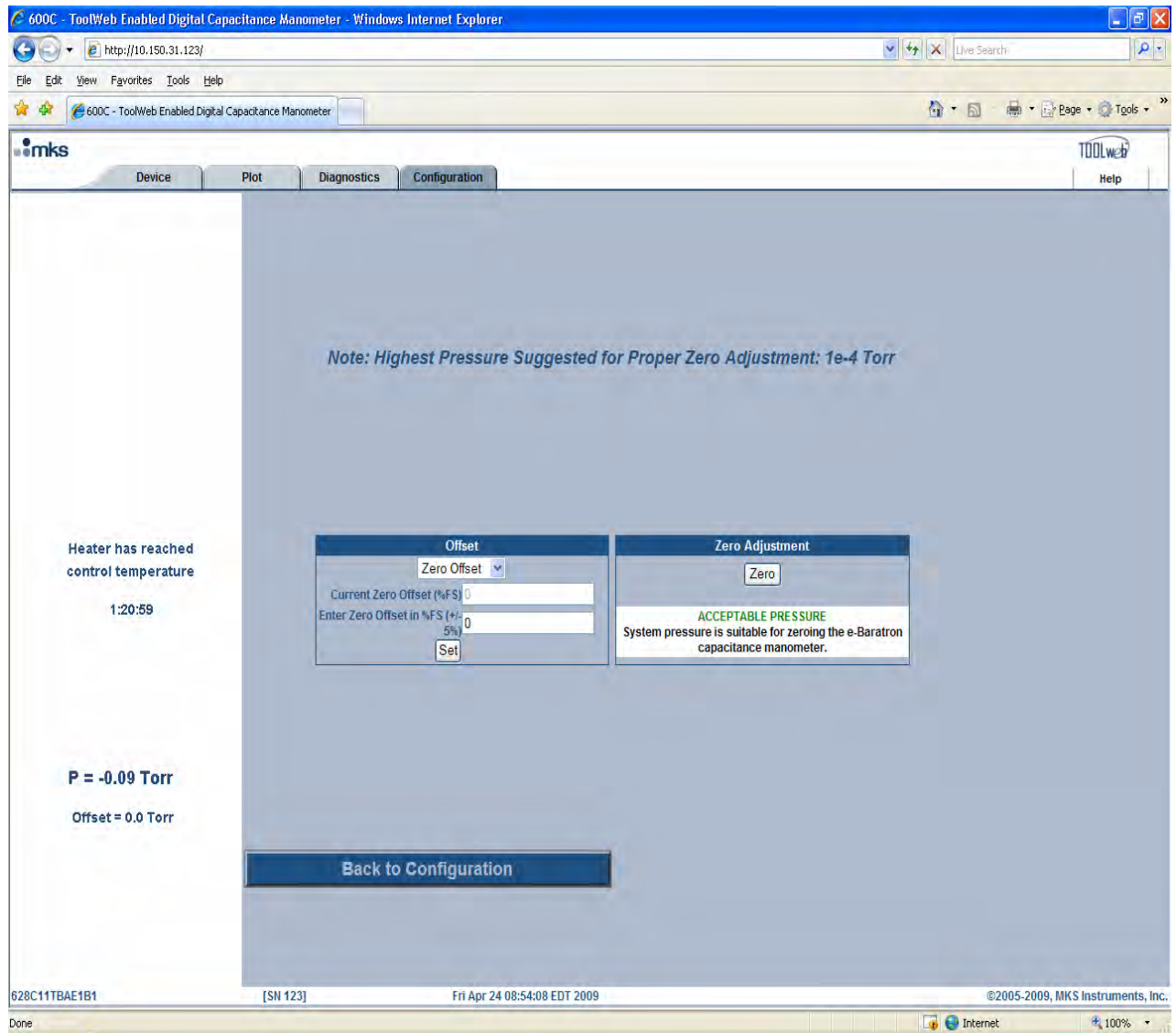

Figure 14: Configuration/ Zero Adjustment with ‘Zero Offset’ Option

Mode 3 – Push-button Zero with Target Offset = $x \% FS$

From the pull-down menu on the Zero Adjustment page select ‘Zero Target’ from the pull-down menu and press the ‘Set’ button.

This will bring up the two cells that need to be filled out. Fill out the cells with appropriate values, press the ‘Set’ button and then the ‘Zero’ button.

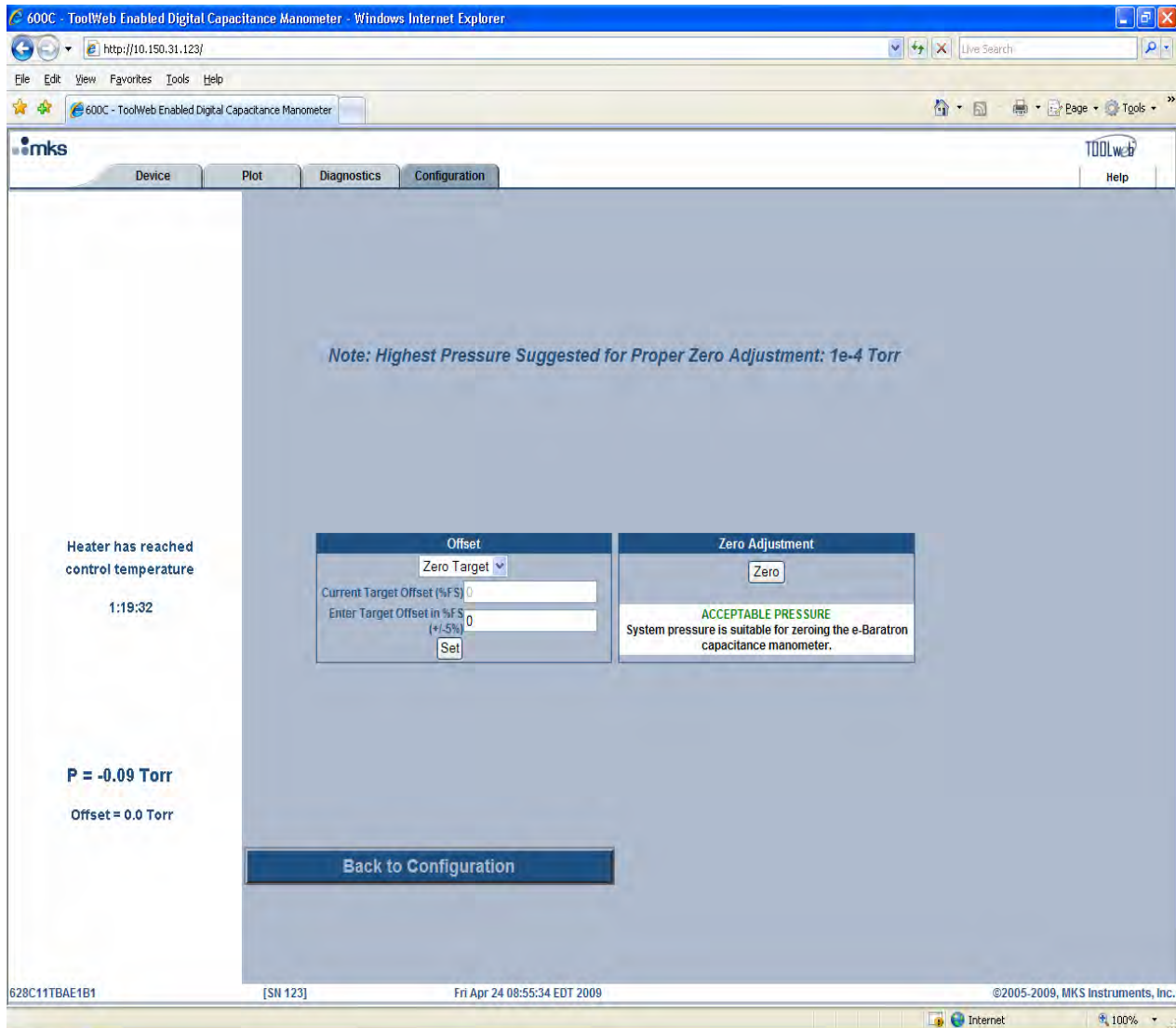

Figure 15: Configuration/ Zero Adjustment with ‘Zero Target’ Option

Configuration / Display Setup Page

The Configuration/Display Setup page provides the user the ability to change the real-time pressure display Refresh Rate and the number of digits of resolution for the pressure shown in the display. A value of zero for the refresh rate “turns off” the automatic updating. A button appears near the bottom of the display that can be pressed for “Manually Refreshing” the real-time pressure display.

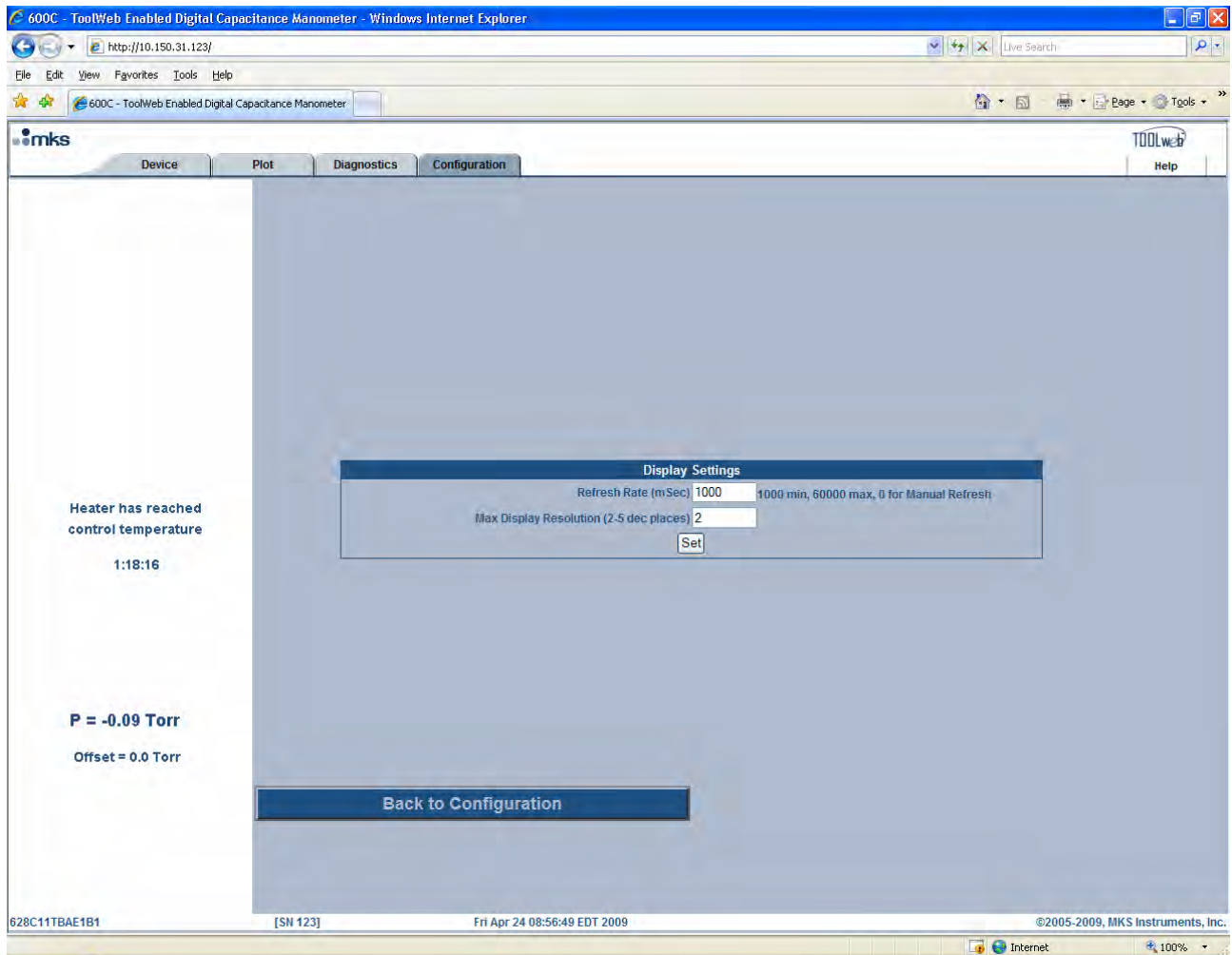

Figure 16: Configuration / Display Setup page

Adjusting the Analog and Digital Zero

1. Install the manometer in a system with a power supply/readout. Refer to Table 9, page 17, for interface connector pin-out assignments.
2. Power the manometer and allow it to warm up and stabilize.



Note Before use, allow the 62xC/E2xC (45° C) and 62xC/E2xC (100° C) to warm up (2 hours for ranges of 1 Torr and higher or 4 hours for ranges less than 1 Torr, as appropriate). Ensure the device is *fully stabilized* before you adjust the manometer zero.

Details of operation of the zero push-button on 62xC/E2xC:

When the sensor has reached control temperature, message reported on the WEB Page will change from 'Standby' to ' '. If the sensor has reached control temperature and the zero change to be adjusted is less than 10% of Full-scale and the cumulative zero change is less than 20% of Full-scale, then pressing and holding the zero push-button for at least two seconds will cause the unit to zero. (If the push-button is pressed for less time than 2 seconds, the unit will not zero).

3. Pump the unit down to a pressure below its resolution (0.01% of FS).

For best results, pump the manometer while it is warming up. The 62xC/E2xC must be evacuated to a pressure below its resolution before the OneTouch Zero Push Button is used. Refer to Table 13, below, for the recommended pressure levels for proper zero adjustment.

The digital and analog outputs can be zeroed either by manually pressing the OneTouch Push Button or by pressing the Zero button on the Web browser.

Table 13: Highest Pressures Suggested for Proper Zero Adjustment

Full Scale Range (Torr)	Highest Pressure for Proper Zero Adjustment (Torr)
0.1	$< 5 \times 10^{-7}$
1	$< 5 \times 10^{-6}$
10	$< 5 \times 10^{-5}$
100	$< 5 \times 10^{-4}$
1000	$< 5 \times 10^{-3}$

Zero Adjustments Modes

62xC/E2xC has three different modes of zero adjustments. It is important that the user become familiar with the specific application and limitations of each three modes before selecting a mode of zero adjustment. Note that each mode of zero adjustment is applied to both analog and digital pressure outputs.

Mode 1. Push-Button Zero with No Offset

Purpose: The unit has drifted and the output reads a non-zero value @ vacuum that needs to be offsetted. When pushing the button, the user wants the pressure output to read zero.

Limit: +/- 20% FS from the factory Zero position.

Method: Bring manifold pressure to vacuum level (ref to table 13 for suggested pressures for proper zero adjustment. Either push the zero push-button or press the Zero button on the Web browser applet with Zero Target = 0 (default value).

Notes: Does not require connection through the Ethernet port.
After push-button, Analog Pressure output at **100% of FS = 10V**

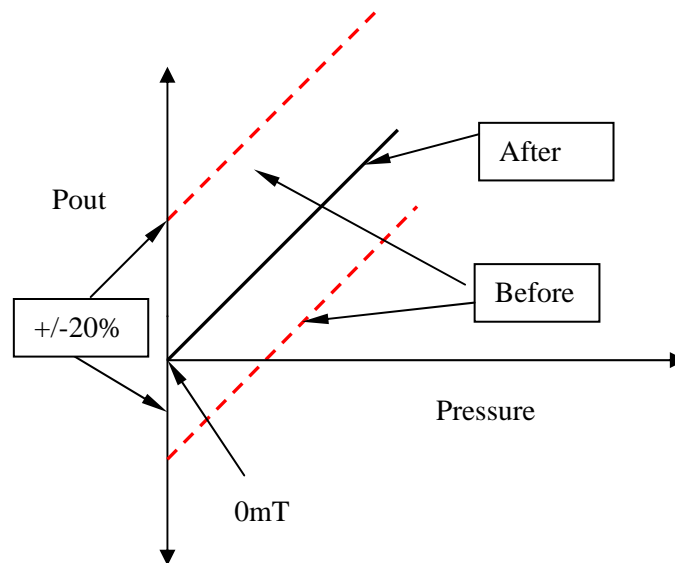

Figure 17: Push-Button Zero with No Offset

Mode 2. Push-Button Zero with Zero Offset = x Fraction of FS

Purpose: The user cannot achieve zero pressure. The user can achieve a known positive pressure. When pushing the button, the user wants Pout to read output equivalent to known offset zero (Target).

Range of Alignment: +/- 5% of FS from Factory Zero position.

Method: Set the required offset = x Fraction of FS through the Ethernet interface. At this target pressure, either push the zero push-button or press the Zero button on the Web browser applet.

Notes: This feature is available only through the Ethernet interface.

Example shown below:
 Adjustment = .05 Fr. of FS.
 After push-button, Analog Pressure output at **100% of FS = 10V**

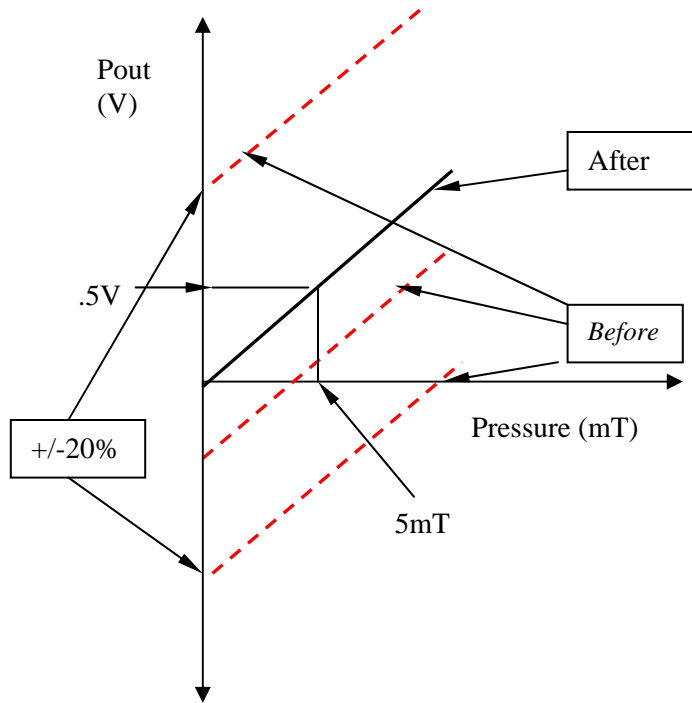

Figure 18: Push-Button Zero with Zero Offset = x Fraction of FS

Mode 3. Push-Button Zero with Target Offset = x Fraction of FS

Purpose: Pressure output goes into an A/D in the unipolar mode. Therefore, the user wants the pressure output to read a positive value at zero pressure.

Limit: +/- 5% 5% FS from the Factory Zero position.

Method: Set the Target = +x Fraction of FS through the Ethernet interface. Now, at zero pressure, either push the zero push-button or press the Zero button on the Web browser applet.

Notes: This feature is available only to customers who would use the Ethernet interface.

Example shown below:

Adjustment = .05 Fr. of FS.

After push-button, Pressure output at **100mT = 10.5V**

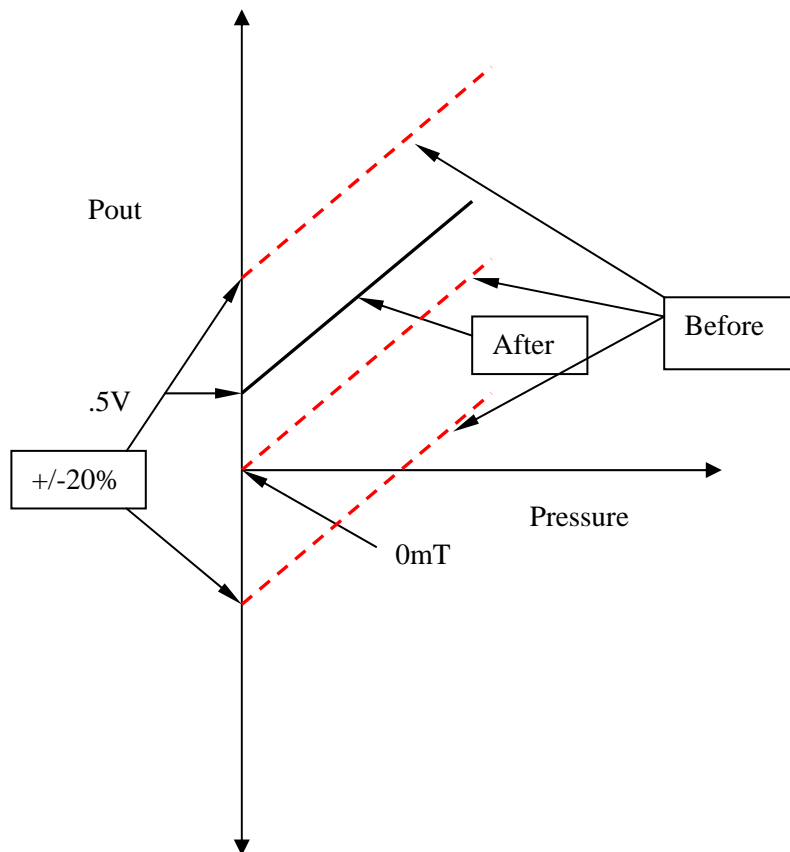

Figure 19: Push-Button Zero with Target Offset = x Fraction of FS

Chapter Five: Maintenance and Troubleshooting

General Information

In general, the 62xC/E2xC manometer requires no maintenance other than proper installation and operation, and an occasional zero adjustment. If the manometer fails to operate properly upon receipt, check for shipping damage and check the cables for correct continuity. Immediately report any damage to the carrier and MKS Instruments.

If there is no obvious damage and the cable continuity is correct, please follow the *Troubleshooting Chart* (Table 14, page 47). If the manometer performance does not improve and it is necessary to return the unit to MKS for service, obtain an RMA Number (Return Material Authorization Number) from any MKS Calibration and Service Center (listed on the inside back cover of this manual) before shipping.

Maintenance

Zero Adjustment

All process manometers require initial and periodic zero adjustments. Prior to initial operation and during periodic maintenance you must check the manometer zero to verify the proper output.

The manometer's pressure signal can be zeroed by manually pressing the One Touch Zero Push Button on the top of the 62xC/E2xC unit (Figure 1, page 14). The unit's zero can also be adjusted using the Web browser.

Refer to *Adjusting the Analog and Digital Zero*, page 34, for complete instructions on adjusting the manometer zeros.

**Note**

In production operations such as semiconductor manufacturing, verify the manometer zero (and adjust if necessary) each time the equipment is shut down for routine maintenance.

Troubleshooting

Table 14: Troubleshooting Chart

Symptom	Possible Cause	Solution
Over-range positive or negative signal.	A shorted manometer or a damaged inter-connect cable (manometer to electronics module).	Measure supply voltages at the connector. Inspect cable and manometer. Replace, if necessary.
Measurement slowly goes positive over time.	Overpressure and/or a build-up of contamination in the measurement cavity.	Return to MKS for servicing or sensor assembly replacement.
Unstable zero output.	The ambient temperature may be too high. <i>Or:</i> The ambient temperature is varying over a wide range.	Refer to <i>Startup</i> , page 18, to ensure the ambient temperature is within product requirements. (Refer also to <i>Appendix A: Product Specifications</i> , page 49).

Appendix A: Product Specifications

Ethernet Communication Specifications

Standard TCP/IP protocol is used in 62xC/E2xC for Ethernet communications.

Electrical Specifications

	627C/E27C (45° C)	628C/E28C (100° C)
CE Compliance Electromagnetic Compatibility ¹ Product Safety Requirements	EMC Directive 2004/108/EEC Product Safety Directive 92/59/EEC	
Input Power Requirements		
Single Power Supply Configuration		
Voltage	+24 VDC +/- 10%	+24 VDC +/- 10%
Current at Warm Up	600 mA (max)	900 mA (max)
Dual Power Supply Configuration		
Voltage	+/-15 VDC +/- 5%	+/-15 VDC +/- 5%
Current at Warm Up	400 mA (max)	700 mA (max)
Signal Output		
Analog Output	0 to 10 VDC, 110% over-range, active zero.	
Digital Output Units	Torr, mBar, Pa, KPa	

¹ Overall metal braided shielded cable, properly grounded at both ends, for use of J2 9-pin “D” connector.

Environmental Specifications

	627C/E27C (45° C)	628C/E28C (100° C)
Maximum External Case Temperature	50° C (122° F)	65° C (149° F)
Temperature Range		
Operating	15° to 40° C (59° to 104° F)	15° to 50° C (59° to 122° F)
Storage	-18° to 80° C (0° to 176° F)	-18° to 80° C (0° to 176° F)
Storage Humidity Range	25% RH to 95% RH (relative humidity), non-condensing	
Warm Up Time	4 hours ranges less than 1 Torr 2 hours ranges 1 Torr and higher	4 hours ranges less than 1 Torr 2 hours ranges 1 Torr and higher

Physical Specifications

Dimensions	
Diameter	3.2" outside diameter
Length	4.3" overall not including port tube or connectors
Fittings	
Standard	½ inch (12.7 mm) tubulation
Optional	½" outside diameter (12.7 mm) tubulation Swagelok 8-VCR (female) Swagelok 8-VCR (male) Mini-CF (rotatable) NW-16-KF NW-25-KF Swagelok 8-VCO (female)
Internal Volume	<7 CC
I/O Connectors	
Analog	9-pin male Type DE-9S Interface 15-pin male Type DE-15S Interface
Digital	Ethernet RJ45
Weight	1.5 lbs (0.68 kg)
Wetted Materials	Inconel®. Some optional fittings may be built from type 316 stainless steel.

Performance Specifications

Accuracy (nonlinearity, hysteresis, and nonrepeatability)	Range (Torr) (% of Reading)	Standard Accuracy (% of Reading)	Optional (% of Reading)
627C/E27C (45° C)	0.1	0.15%	
	1, 2, 10, 20, 100, 1000	0.12%	
628C/E28C (100° C)	0.1	0.5%	
	1, 2, 10, 20, 100, 1000	0.25%	
Temperature Coefficients	Range	Zero (% Full Scale/°C)	Span (% Reading/°C)
627C/E27C (45° C)	0.1 Torr	0.005%	0.02%
	1 Torr and up	0.002%	0.02%
628C/E28C (100° C)	0.1 Torr	0.01%	0.02%
	1 Torr and up	0.002%	0.02%
Burst Pressure	5 times Full Scale or 90 psia, whichever is greater		
Leak Integrity	Internal to external 10^{-9} scc/sec He 100 million cycles to FS without leakage–1 million cycles for ≤1 Torr		
Overpressure Limit Without Damage	45 psia (310 kPa)		
Resolution 0.1 to 1000T units	0.001% Full Scale		
Time Constant (Analog Output)	< 20 msec (< 40 msec ≤ 1 Torr units)		
Media Compatibility	Any gas compatible with Inconel® and 316 stainless steel		

Due to continuing research and development activities, these product specifications are subject to change without notice.

This page intentionally left blank.

Appendix B: Model Code Explanation

Model Code

The options for your manometer are identified in the model code when you order the unit. The model code for your manometer is:

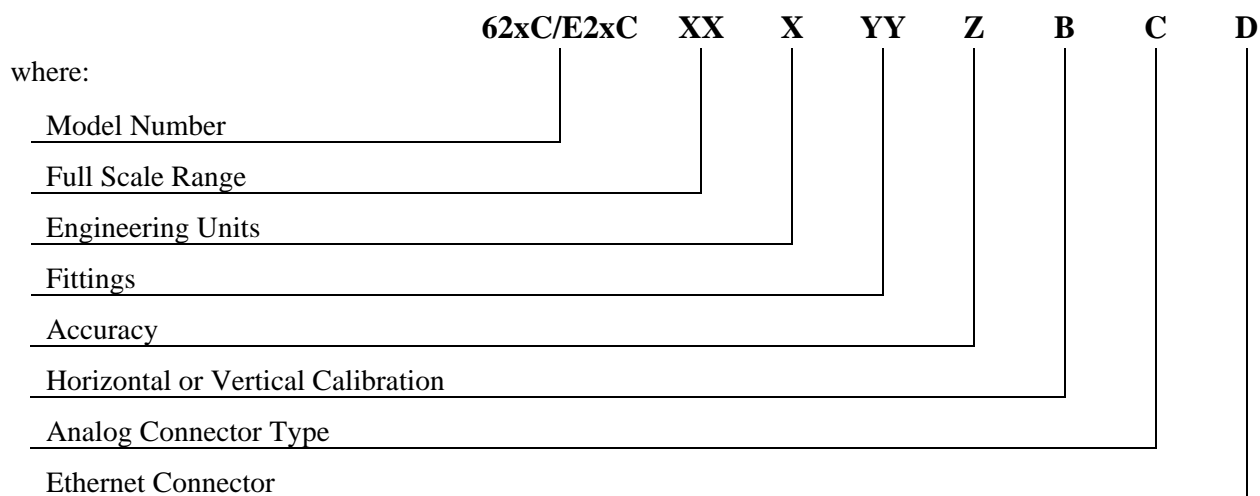

Model Number (62xC/E2xC)

This designates the model number of the instrument as 62xC/E2xC.

Model Number	Ordering Code
Heated to 45° C	627C
Heated to 100° C	628C
Etch sensor, 45° C*	E27C
Etch sensor, 100° C*	E28C

* Etch sensor only available in ranges from 0.1 to 100 Torr.

Full Scale Range (XX)

The full scale range in Torr is indicated by a 2-character code.

Full Scale Range (mmHg/Torr)	Ordering Code
0.10	.1
1	01
2	02
10	11
20	21
100	12
1000	13

Engineering Units (X)

The engineering units are indicated by a single letter code.

Units	Ordering Code
Torr/mmHg	T
mBar	M
kiloPascal	K
Pascal	L

Fittings (YY)

Several types of fittings are available, designated by a 2-character code.

Type	Ordering Code
Straight 0.50" OD tube	BA
8 VCR [®] female	CE
8 VCR male	CF
8 VCR female, short tube and gland	CR
NW16-KF	GA
NW25-KF	GC
8 VCO [®] female	DA
Mini-CF rotatable	HA

Accuracy (Z)

The accuracy is specified by a single letter code.

Accuracy	Ordering Code
0.12% of Reading 45° C, 1.0 thru 1000 Torr	C
0.15% of Reading 45° C, .1 Torr	D
0.25% of Reading 100° C, 1.0 thru 1000 Torr	E
0.50% of Reading 100° C, .1 Torr	F

Calibration Type (B)

The calibration type is designated by a single letter code.

Calibration Type	Ordering Code
Horizontal Calibration, <1 Torr only	5
Vertical Calibration (standard)	1

Analog Connector Type (C)

Analog connector is designated by a single number code.

Analog Connector Type	Ordering Code
15-pin D-subminiature, thread lock	B
15-pin D-subminiature, slide lock	P
9-pin D-subminiature, thread lock	A
9-pin D-subminiature, slide lock	Z

Digital Connector (D)

Ethernet connector is designated by a single number code.

Digital Connector Type	Ordering Code
Ethernet RJ45 port	1

INDEX

- Accuracy, 57
- Alarm, 24, 39
- Ambient Operating Temperature, 13
- Cables, 11, 12, 13
- CE Compliance, 51
- Configuration Page, 37
- Configuration/ Limit Settings Page, 39
- Configuration/ Network Settings Page, 38
- Configuration/ Zero Adjustment Page, 40
- Connector, 9, 11, 12, 13, 23, 24, 28, 45, 50, 51, 57
- Customer Support, 10
- Device Page, 32
- Device/Events Page, 33
- Device/Information Page, 34
- Diagnostics Page, 36
- Digital zero, 45
- Dimensions, 15, 52
- EMC Directive, 11, 51
- Environmental, 52
- Ethernet, 9, 10, 13, 23, 24, 28, 29, 38, 46, 47, 48, 51, 52, 55, 57
- Fittings, 52, 56, 57
- Full scale range, 20, 45, 55, 56
- Ground, 1, 12, 16
- Humidity, 52
- Input power, 9
- IP address, 9, 28, 29, 30
- Isolation valve, 16
- Java RunTime Environment, 28, 31
- Label, 16
- LEDs
 - power up sequence, 19
- MAC ID, 28
- Maintenance, 49
- Model code, 55–57
- Mounting Instructions, 16
- Output signal, 9, 23, 24
- Overpressure, 50
- Performance Specifications, 53
- Physical Specifications, 52
- Plot Page, 35
- Power requirements, 51
- Power Supply, 12
- Power up, 19
- Pressure
 - lowest for control, 20
 - lowest for reading, 20
- Pressure measurement, description of, 24
- Product Specifications, 51
- Returning the product, 49
- RMA Number, 10, 11, 49
- Sensor, description of, 23
- Setup, 15, 37, 44
- Signal Conditioner/Electronics, 23
- Startup
 - LED sequence, 19
 - pressures for reading and control, 20
 - warm up time, 19
 - zero adjustment, 19
- Status LED, 19, 24
- Temperature Coefficients, 53
- TOOLweb, 9, 23
- Troubleshooting, 49
- Vibration, 16
- Warm up time, 19
- Web Pages, 31

Zero adjustment, 19, 49
digital (zero offset), 45

Zero Adjustments Modes, 46
Zeros, description of, 45