



123655-P1
Rev A, 4/99
Instruction Manual

MKS Type 870B/872B Micro-Baratron® Absolute Pressure Transducer



WARRANTY

Type 870B/872B Equipment

MKS Instruments, Inc. (**MKS**) warrants that for two years from the date of shipment the equipment described above (the "equipment") manufactured by **MKS** shall be free from defects in materials and workmanship and will correctly perform all date-related operations, including without limitation accepting data entry, sequencing, sorting, comparing, and reporting, regardless of the date the operation is performed or the date involved in the operation, provided that, if the equipment exchanges data or is otherwise used with equipment, software, or other products of others, such products of others themselves correctly perform all date-related operations and store and transmit dates and date-related data in a format compatible with **MKS** equipment. THIS WARRANTY IS **MKS'** SOLE WARRANTY CONCERNING DATE-RELATED OPERATIONS.

For the period commencing with the date of shipment of this equipment and ending two years later, **MKS** will, at its option, either repair or replace any part which is defective in materials or workmanship or with respect to the date-related operations warranty without charge to the purchaser. The foregoing shall constitute the exclusive and sole remedy of the purchaser for any breach by **MKS** of this warranty.

The purchaser, before returning any equipment covered by this warranty, which is asserted to be defective by the purchaser, shall make specific written arrangements with respect to the responsibility for shipping the equipment and handling any other incidental charges with the **MKS** sales representative or distributor from which the equipment was purchased or, in the case of a direct purchase from **MKS**, with the **MKS** home office in Andover, Massachusetts, USA.

This warranty does not apply to any equipment which has not been installed and used in accordance with the specifications recommended by **MKS** for the proper and normal use of the equipment. **MKS** shall not be liable under any circumstances for indirect, special, consequential, or incidental damages in connection with, or arising out of, the sale, performance, or use of the equipment covered by this warranty.

MKS recommends that all **MKS** pressure and flow products be calibrated periodically (typically every 6 to 12 months) to ensure accurate readings. When a product is returned to **MKS** for this periodic re-calibration it is considered normal preventative maintenance not covered by any warranty.

THIS WARRANTY IS IN LIEU OF ALL OTHER RELEVANT WARRANTIES, EXPRESSED OR IMPLIED, INCLUDING THE IMPLIED WARRANTY OF MERCHANTABILITY AND THE IMPLIED WARRANTY OF FITNESS FOR A PARTICULAR PURPOSE, AND ANY WARRANTY AGAINST INFRINGEMENT OF ANY PATENT.

11-98

123655-P1

SPECIAL NOTICE

This warranty is void if the product is installed using single or double metal ferrule compression type vacuum fittings, shown below. These fittings are commonly tightened incorrectly, causing damage to the pressure sensor.

Single Ferrule

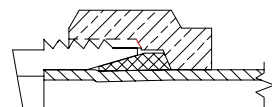

Double Ferrule

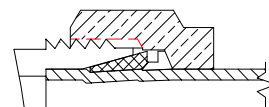

**MKS Type 870B/872B
Micro-Baratron®
Absolute Pressure Transducer**

Copyright © 2001 by MKS Instruments, Inc.

All rights reserved. No part of this work may be reproduced or transmitted in any form or by any means, electronic or mechanical, including photocopying and recording, or by any information storage or retrieval system, except as may be expressly permitted in writing by MKS Instruments, Inc.

Printed in the United States of America

Baratron[®] is a registered trademark of MKS Instruments, Inc., Andover, MA

Bendix[®] is a registered trademark of Amphenol Corp., Bendix Connector Operations., Sidney, NY

Inconel[®] and Incoloy[®] are registered trademarks of Inco Alloys International, Huntington, WV

Swagelok[®] and VCR[®] are registered trademarks of Swagelok Marketing Co., Solon, OH

Table of Contents

| | |
|---|----|
| Pressure Transducer Safety Information | 2 |
| Symbols Used in This Instruction Manual..... | 2 |
| Symbols Found on the Unit..... | 3 |
| Safety Procedures and Precautions..... | 4 |
| Sicherheitshinweise für den Druckmeßumformer..... | 6 |
| In dieser Betriebsanleitung vorkommende Symbole | 6 |
| Erklärung der am Gerät angebrachten Symbole | 7 |
| Sicherheitsvorschriften und Vorsichtsmaßnahmen..... | 8 |
| Informations relatives à la sécurité pour le transducteur de pression | 10 |
| Symboles utilisés dans ce manuel d'utilisation..... | 10 |
| Symboles apparaissant sur l'unité | 11 |
| Mesures de sécurité et précautions | 12 |
| Medidas de seguridad del transductor de presión..... | 14 |
| Símbolos usados en este manual de instrucciones..... | 14 |
| Símbolos hallados en la unidad..... | 15 |
| Procedimientos y precauciones de seguridad..... | 16 |
| Chapter One: General Information | 19 |
| Introduction..... | 19 |
| How This Manual is Organized..... | 20 |
| Customer Support..... | 20 |
| Chapter Two: Installation | 21 |
| How To Unpack the Type 870/872 Unit..... | 21 |
| Ultraclean Units | 21 |
| Unpacking Checklist | 22 |
| Product Location and Requirements..... | 22 |
| Operating Temperature..... | 22 |
| Power Requirements | 22 |

| | |
|--|----|
| Interface Cables..... | 23 |
| Generic Shielded Cables..... | 24 |
| Setup..... | 25 |
| Dimensions | 25 |
| Mounting Instructions..... | 29 |
| Welded Connections | 29 |
| Mechanical Connections | 29 |
| Electrical Information..... | 30 |
| Voltage Unit..... | 30 |
| Current Unit..... | 31 |
| Connectors..... | 33 |
| Flying Leads..... | 34 |
| Bendix Connectors | 35 |
| Type “D” Connectors | 36 |
| Startup..... | 38 |
| Chapter Three: Overview..... | 39 |
| General Information..... | 39 |
| Sensor | 39 |
| Signal Conditioner..... | 39 |
| Labels..... | 40 |
| Serial Number Label..... | 40 |
| Information Label..... | 40 |
| Bendix Connector Warning Label..... | 41 |
| Chapter Four: Operation..... | 43 |
| How To Adjust the Zero..... | 43 |
| Chapter Five: Maintenance and Troubleshooting..... | 45 |
| General Information..... | 45 |
| Maintenance | 45 |
| Zero Adjustment..... | 45 |
| Troubleshooting..... | 46 |
| Appendix A: Product Specifications | 49 |

| | |
|--|----|
| Performance Specifications | 49 |
| Electrical Specifications | 49 |
| Physical Specifications | 50 |
| Environmental Specifications | 51 |
| Appendix B: Model Code Explanation | 53 |
| Model Code | 53 |
| Index | 57 |

List of Figures

| | |
|---|----|
| Figure 1: Dimensions of the Type 870 Transducer..... | 25 |
| Figure 2: Dimensions of Additional Fittings for the Type 870 Transducer | 26 |
| Figure 3: Dimensions of the Type 872 Transducer..... | 27 |
| Figure 4: Dimensions of Additional Fittings for the Type 872 Transducer | 28 |
| Figure 5: Electrical Scheme for a Voltage Unit | 30 |
| Figure 6: Line Resistance Equation | 31 |
| Figure 7: Total Resistance in Line | 31 |
| Figure 8: Electrical Scheme for a Current (4 to 20 mA) Unit..... | 32 |
| Figure 9: Flying Leads | 34 |
| Figure 10: Bendix Connector | 35 |
| Figure 11: 9-Pin Standard Type “D” Connector | 36 |
| Figure 12: 15-Pin High Density Type “D” Connector | 37 |
| Figure 13: Serial Number Label..... | 40 |
| Figure 14: Information Label..... | 40 |
| Figure 15: Bendix Connector Warning Label..... | 41 |

List of Tables

| | |
|--|----|
| Table 1: Definition of Symbols Found on the Unit | 3 |
| Tabelle 2: Bedeutung der am Gerät angebrachten Symbole | 7 |
| Tableau 3: Définition des symboles apparaissant sur l'unité | 11 |
| Tabla 4: Definición de los símbolos hallados en la unidad | 15 |
| Table 5: Power Requirements..... | 22 |
| Table 6: Interface Cables | 24 |
| Table 7: Connector Options | 33 |
| Table 8: Flying Lead Pinout (Model Code F)..... | 34 |
| Table 9: Flying Lead Pinout (Model Code L) | 34 |
| Table 10: Bendix Connector Pinout (Model Code D)..... | 35 |
| Table 11: Bendix Connector Pinout (Model Code H)..... | 36 |
| Table 12: 9-Pin Standard Type “D” Connector Pinout | 36 |
| Table 13: 15-Pin High Density Type “D” Connector Pinout | 37 |
| Table 14: Highest Pressures Suggested for Proper Zero Adjustment | 44 |
| Table 15: Troubleshooting Chart | 47 |

Pressure Transducer Safety Information

Symbols Used in This Instruction Manual

Definitions of WARNING, CAUTION, and NOTE messages used throughout the manual.

Warning



The **WARNING** sign denotes a hazard to personnel. It calls attention to a procedure, practice, condition, or the like, which, if not correctly performed or adhered to, could result in injury to personnel.

Caution



The **CAUTION** sign denotes a hazard to equipment. It calls attention to an operating procedure, practice, or the like, which, if not correctly performed or adhered to, could result in damage to or destruction of all or part of the product.

Note



The **NOTE** sign denotes important information. It calls attention to a procedure, practice, condition, or the like, which is essential to highlight.

Symbols Found on the Unit

The following table describes symbols that may be found on the unit.















| Definition of Symbols Found on the Unit | | | |
|---|---|--|---|
|  |  |  |  |
| On (Supply) IEC 417, No.5007 | Off (Supply) IEC 417, No.5008 | Earth (ground) IEC 417, No.5017 | Protective earth (ground) IEC 417, No.5019 |
|  |  |  |  |
| Frame or chassis IEC 417, No.5020 | Equipotentiality IEC 417, No.5021 | Direct current IEC 417, No.5031 | Alternating current IEC 417, No.5032 |
|  |  |  | |
| Both direct and alternating current IEC 417, No.5033-a | Class II equipment IEC 417, No.5172-a | Three phase alternating current IEC 617-2 No.020206 | |
|  |  |  | |
| Caution, refer to accompanying documents ISO 3864, No.B.3.1 | Caution, risk of electric shock ISO 3864, No.B.3.6 | Caution, hot surface IEC 417, No.5041 | |

Table 1: Definition of Symbols Found on the Unit

Safety Procedures and Precautions

Observe the following general safety precautions during all phases of operation of this instrument. Failure to comply with these precautions or with specific warnings elsewhere in this manual violates safety standards of intended use of the instrument and may impair the protection provided by the equipment. MKS Instruments, Inc. assumes no liability for the customer's failure to comply with these requirements.

DO NOT SUBSTITUTE PARTS OR MODIFY INSTRUMENT

Do not install substitute parts or perform any unauthorized modification to the instrument. Return the instrument to an MKS Calibration and Service Center for service and repair to ensure that all safety features are maintained.

SERVICE BY QUALIFIED PERSONNEL ONLY

Operating personnel must not attempt component replacement and internal adjustments. Any service must be made by qualified service personnel only.

USE CAUTION WHEN OPERATING WITH HAZARDOUS MATERIALS

If hazardous materials are used, users must take responsibility to observe the proper safety precautions, completely purge the instrument when necessary, and ensure that the material used is compatible with the materials in this product, including any sealing materials.

PURGE THE INSTRUMENT

After installing the unit, or before removing it from a system, purge the unit completely with a clean, dry gas to eliminate all traces of the previously used flow material.

USE PROPER PROCEDURES WHEN PURGING

This instrument must be purged under a ventilation hood, and gloves must be worn for protection.

DO NOT OPERATE IN AN EXPLOSIVE ENVIRONMENT

To avoid explosion, do not operate this product in an explosive environment unless it has been specifically certified for such operation.

USE PROPER FITTINGS AND TIGHTENING PROCEDURES

All instrument fittings must be consistent with instrument specifications, and compatible with the intended use of the instrument. Assemble and tighten fittings according to manufacturer's directions.

CHECK FOR LEAK-TIGHT FITTINGS

Carefully check all vacuum component connections to ensure leak-tight installation.

OPERATE AT SAFE INLET PRESSURES

Never operate at pressures higher than the rated maximum pressure (refer to the product specifications for the maximum allowable pressure).

INSTALL A SUITABLE BURST DISC

When operating from a pressurized gas source, install a suitable burst disc in the vacuum system to prevent system explosion should the system pressure rise.

KEEP THE UNIT FREE OF CONTAMINANTS

Do not allow contaminants to enter the unit before or during use. Contamination such as dust, dirt, lint, glass chips, and metal chips may permanently damage the unit or contaminate the process.

ALLOW PROPER WARM UP TIME FOR TEMPERATURE-CONTROLLED UNITS

Temperature-controlled units will only meet specifications when sufficient time is allowed for the unit to meet, and stabilize at, the designed operating temperature. Do not zero or calibrate the unit until the warm up is complete.

Sicherheitshinweise für den Druckmeßumformer

In dieser Betriebsanleitung vorkommende Symbole

Bedeutung der mit WARNUNG!, VORSICHT! und HINWEIS gekennzeichneten Absätze in dieser Betriebsanleitung.

Warnung!



Das Symbol **WARNUNG!** weist auf eine Gefahr für das Bedienpersonal hin. Es macht auf einen Arbeitsablauf, eine Arbeitsweise, einen Zustand oder eine sonstige Gegebenheit aufmerksam, deren unsachgemäße Ausführung bzw. ungenügende Berücksichtigung zu Verletzungen führen kann.

Vorsicht!



Das Symbol **VORSICHT!** weist auf eine Gefahr für das Gerät hin. Es macht auf einen Bedienungsablauf, eine Arbeitsweise oder eine sonstige Gegebenheit aufmerksam, deren unsachgemäße Ausführung bzw. ungenügende Berücksichtigung zu einer Beschädigung oder Zerstörung des Gerätes oder von Teilen des Gerätes führen kann.

Hinweis



Das Symbol **HINWEIS** macht auf wichtige Informationen bezüglich eines Arbeitsablaufs, einer Arbeitsweise, eines Zustands oder einer sonstige Gegebenheit aufmerksam.

Erklärung der am Gerät angebrachten Symbole

Nachstehender Tabelle sind die Bedeutungen der Symbole zu entnehmen, die am Gerät angebracht sein können.















| Bedeutung der am Gerät angebrachten Symbole | | | |
|---|---|--|---|
|  |  |  |  |
| Ein (Energie) IEC 417, No.5007 | Aus (Energie) IEC 417, No.5008 | Erdanschluß IEC 417, No.5017 | Schutzleiteranschluß IEC 417, No.5019 |
|  |  |  |  |
| Masseanschluß IEC 417, No.5020 | Aquipotential-anschluß IEC 417, No.5021 | Gleichstrom IEC 417, No.5031 | Wechselstrom IEC 417, No.5032 |
|  |  |  | |
| Gleich- oder Wechselstrom IEC 417, No.5033-a | Durchgängige doppelte oder verstärkte Isolierung IEC 417, No.5172-a | Dreileiter- Wechselstrom (Drehstrom) IEC 617-2, No.020206 | |
|  |  |  | |
| Warnung vor einer Gefahrenstelle (Achtung, Dokumenta- tion beachten) ISO 3864, No.B.3.1 | Warnung vor gefährlicher elektrischer Spannung ISO 3864, No.B.3.6 | Höhere Temperatur an leicht zugänglichen Teilen IEC 417, No.5041 | |

Tabelle 2: Bedeutung der am Gerät angebrachten Symbole

Sicherheitsvorschriften und Vorsichtsmaßnahmen

Folgende allgemeine Sicherheitsvorschriften sind während allen Betriebsphasen dieses Gerätes zu befolgen. Eine Mißachtung der Sicherheitsvorschriften und sonstiger Warnhinweise in dieser Betriebsanleitung verletzt die für dieses Gerät und seine Bedienung geltenden Sicherheitsstandards, und kann die Schutzvorrichtungen an diesem Gerät wirkungslos machen. MKS Instruments, Inc. haftet nicht für Mißachtung dieser Sicherheitsvorschriften seitens des Kunden.

Niemals Teile austauschen oder Änderungen am Gerät vornehmen!

Ersetzen Sie keine Teile mit baugleichen oder ähnlichen Teilen, und nehmen Sie keine eigenmächtigen Änderungen am Gerät vor. Schicken Sie das Gerät zwecks Wartung und Reparatur an den MKS-Kalibrierungs- und -Kundendienst ein. Nur so wird sichergestellt, daß alle Schutzvorrichtungen voll funktionsfähig bleiben.

Wartung nur durch qualifizierte Fachleute!

Das Auswechseln von Komponenten und das Vornehmen von internen Einstellungen darf nur von qualifizierten Fachleuten durchgeführt werden, niemals vom Bedienpersonal.

Vorsicht beim Arbeiten mit gefährlichen Stoffen!

Wenn gefährliche Stoffe verwendet werden, muß der Bediener die entsprechenden Sicherheitsvorschriften genauestens einhalten, das Gerät, falls erforderlich, vollständig spülen, sowie sicherstellen, daß der Gefahrstoff die am Gerät verwendeten Materialien, insbesondere Dichtungen, nicht angreift.

Spülen des Gerätes mit Gas!

Nach dem Installieren oder vor dem Ausbau aus einem System muß das Gerät unter Einsatz eines reinen Trockengases vollständig gespült werden, um alle Rückstände des Vorgängermediums zu entfernen.

Anweisungen zum Spülen des Gerätes

Das Gerät darf nur unter einer Ablufthaube gespült werden. Schutzhandschuhe sind zu tragen.

Gerät nicht zusammen mit explosiven Stoffen, Gasen oder Dämpfen benutzen!

Um der Gefahr einer Explosion vorzubeugen, darf dieses Gerät niemals zusammen mit (oder in der Nähe von) explosiven Stoffen aller Art eingesetzt werden, sofern es nicht ausdrücklich für diesen Zweck zugelassen ist.

Anweisungen zum Installieren der Armaturen!

Alle Anschlußstücke und Armaturenteile müssen mit der Gerätespezifikation übereinstimmen, und mit dem geplanten Einsatz des Gerätes kompatibel sein. Der Einbau, insbesondere das Anziehen und Abdichten, muß gemäß den Anweisungen des Herstellers vorgenommen werden.

Verbindungen auf Undichtigkeiten prüfen!

Überprüfen Sie sorgfältig alle Verbindungen der Vakuumkomponenten auf undichte Stellen.

Gerät nur unter zulässigen Anschlußdrücken betreiben!

Betreiben Sie das Gerät niemals unter Drücken, die den maximal zulässigen Druck (siehe Produktspezifikationen) übersteigen.

Geeignete Berstscheibe installieren!

Wenn mit einer unter Druck stehenden Gasquelle gearbeitet wird, sollte eine geeignete Berstscheibe in das Vakuumsystem installiert werden, um eine Explosionsgefahr aufgrund von steigendem Systemdruck zu vermeiden.

Verunreinigungen im Gerät vermeiden!

Stellen Sie sicher, daß Verunreinigungen jeglicher Art weder vor dem Einsatz noch während des Betriebs in das Instrumenteninnere gelangen können. Staub- und Schmutzpartikel, Glassplitter oder Metallspäne können das Gerät dauerhaft beschädigen oder Prozeß und Meßwerte verfälschen.

Bei Geräten mit Temperaturkontrolle korrekte Anwärmzeit einhalten!

Temperaturkontrollierte Geräte arbeiten nur dann gemäß ihrer Spezifikation, wenn genügend Zeit zum Erreichen und Stabilisieren der Betriebstemperatur eingeräumt wird. Kalibrierungen und Nulleinstellungen sollten daher nur nach Abschluß des Anwärmvorgangs durchgeführt werden.

Informations relatives à la sécurité pour le transducteur de pression

Symboles utilisés dans ce manuel d'utilisation

Définitions des indications AVERTISSEMENT, ATTENTION, et REMARQUE utilisées dans ce manuel.

Avertissement



L'indication AVERTISSEMENT signale un danger pour le personnel. Elle attire l'attention sur une procédure, une pratique, une condition, ou toute autre situation présentant un risque d'accident pour le personnel, en cas d'exécution incorrecte ou de non respect des consignes.

Attention



L'indication ATTENTION signale un danger pour l'appareil. Elle attire l'attention sur une procédure d'exploitation, une pratique, ou toute autre situation, présentant un risque d'endommagement ou de destruction d'une partie ou de la totalité de l'appareil, en cas d'exécution incorrecte ou de non respect des consignes.

Remarque



L'indication REMARQUE signale une information importante. Elle attire l'attention sur une procédure, une pratique, une condition, ou toute autre situation, présentant un intérêt particulier.

Symboles apparaissant sur l'unité

Le tableau suivant décrit les symboles pouvant apparaître sur l'unité.















| Définition des symboles apparaissant sur l'unité | | | |
|---|---|--|---|
|  |  |  |  |
| Marche (sous tension) IEC 417, No.5007 | Arrêt (hors tension) IEC 417, No.5008 | Terre (masse) IEC 417, No.5017 | Terre de protection (masse) IEC 417, No.5019 |
|  |  |  |  |
| Masse IEC 417, No.5020 | Equipotentialité IEC 417, No.5021 | Courant continu IEC 417, No.5031 | Courant alternatif IEC 417, No.5032 |
|  |  |  | |
| Courant continu et alternatif IEC 417, No.5033-a | Matériel de classe II IEC 417, No.5172-a | Courant alternatif triphase IEC 617-2, No.020206 | |
|  |  |  | |
| Attention : se reporter à la documentation ISO 3864, No.B.3.1 | Attention : risque de choc électrique ISO 3864, No.B.3.6 | Attention : surface brûlante IEC 417, No.5041 | |

Tableau 3: Définition des symboles apparaissant sur l'unité

Mesures de sécurité et précautions

Prendre les précautions générales de sécurité suivantes pendant toutes les phases d'exploitation de cet appareil. Le non respect des ces précautions ou des avertissements contenus dans ce manuel constitue une violation des normes de sécurité relatives à l'utilisation de l'appareil et peut diminuer la protection fournie par l'appareil. MKS Instruments, Inc. n'assume aucune responsabilité concernant le non respect des consignes par les clients.

PAS DE SUBSTITUTION DE PIÈCES OU DE MODIFICATION DE L'APPAREIL

Ne pas installer des pièces de substitution ou effectuer des modifications non autorisées sur l'appareil. Renvoyer l'appareil à un centre de service et de calibrage MKS pour tout dépannage ou réparation afin de garantir le l'intégrité des dispositifs de sécurité.

DÉPANNAGE UNIQUEMENT PAR DU PERSONNEL QUALIFIÉ

Le personnel d'exploitation ne doit pas essayer de remplacer des composants ou de faire des réglages internes. Tout dépannage doit être uniquement effectué par du personnel qualifié.

PRÉCAUTION EN CAS D'UTILISATION AVEC DES PRODUITS DANGEREUX

Si des produits dangereux sont utilisés, l'utilisateur est responsable de la prise des mesures de précaution appropriées, de la purge complète de l'appareil quand cela est nécessaire, et de la garantie que les produits utilisés sont compatibles avec les composants de cet appareil, y compris les matériaux d'étanchéité.

PURGE DE L'APPAREIL

Après l'installation de l'unité, ou avant son enlèvement d'un système, purger l'unité complètement avec un gaz propre et sec afin d'éliminer toute trace du produit de flux utilisé précédemment.

UTILISATION DES PROCÉDURES APPROPRIÉES POUR LA PURGE

Cet appareil doit être purgé sous une hotte de ventilation, et il faut porter des gants de protection.

PAS D'EXPLOITATION DANS UN ENVIRONNEMENT EXPLOSIF

Pour éviter toute explosion, ne pas utiliser cet appareil dans un environnement explosif, sauf en cas d'homologation spécifique pour une telle exploitation.

UTILISATION D'ÉQUIPEMENTS APPROPRIÉS ET PROCÉDURES DE SERRAGE

Tous les équipements de l'appareil doivent être cohérents avec ses spécifications, et compatibles avec l'utilisation prévue de l'appareil. Assembler et serrer les équipements conformément aux directives du fabricant.

VÉRIFICATION DE L'ÉTANCHÉITÉ DES CONNEXIONS

Vérifier attentivement toutes les connexions des composants pour le vide afin de garantir l'étanchéité de l'installation.

EXPLOITATION AVEC DES PRESSIONS D'ENTRÉE NON DANGEREUSES

Ne jamais utiliser des pressions supérieures à la pression nominale maximum (se reporter aux spécifications de l'unité pour la pression maximum admissible).

INSTALLATION D'UN DISQUE D'ÉCHAPPEMENT ADAPTÉ

En cas d'exploitation avec une source de gaz pressurisé, installer un disque d'échappement adapté dans le système à vide, afin d'éviter une explosion du système en cas d'augmentation de la pression.

MAINTIEN DE L'UNITÉ À L'ABRI DES CONTAMINATIONS

Ne pas laisser des produits contaminants pénétrer dans l'unité avant ou pendant l'utilisation. Des produits contaminants tels que des poussières et des fragments de tissu, de glace et de métal peuvent endommager l'unité d'une manière permanente ou contaminer le processus.

RESPECT DU TEMPS D'ÉCHAUFFEMENT APPROPRIÉ POUR LES UNITÉS À TEMPÉRATURE CONTRÔLÉE

Les unités à température contrôlée atteignent leurs spécifications uniquement quand on leur laisse un temps suffisant pour atteindre d'une manière stable la température d'exploitation. Ne pas remettre à zéro ou calibrer l'unité tant que l'échauffement n'est pas terminé.

Medidas de seguridad del transductor de presión

Símbolos usados en este manual de instrucciones

Definiciones de los mensajes de advertencia, precaución y de las notas usados en el manual.

Advertencia



El símbolo de advertencia indica la posibilidad de que se produzcan daños personales. Pone de relieve un procedimiento, práctica, estado, etc. que en caso de no realizarse u observarse correctamente puede causar daños personales.

Precaución



El símbolo de precaución indica la posibilidad de producir daños al equipo. Pone de relieve un procedimiento operativo, práctica, estado, etc. que en caso de no realizarse u observarse correctamente puede causar daños o la destrucción total o parcial del equipo.

Nota



El símbolo de notas indica información de importancia. Este símbolo pone de relieve un procedimiento, práctica o condición cuyo conocimiento es esencial destacar.

Símbolos hallados en la unidad

La tabla siguiente contiene los símbolos que puede hallar en la unidad.















| Definición de los símbolos hallados en la unidad | | | |
|---|---|--|---|
|  |  |  |  |
| Encendido (alimentación eléctrica) IEC 417, N° 5007 | Apagado (alimentación eléctrica) IEC 417, N° 5008 | Puesta a tierra IEC 417, N° 5017 | Protección a tierra IEC 417, N° 5019 |
|  |  |  |  |
| Caja o chasis IEC 417, N° 5020 | Equipotencialidad IEC 417, N° 5021 | Corriente continua IEC 417, N° 5031 | Corriente alterna IEC 417, N° 5032 |
|  |  |  | |
| Corriente continua y alterna IEC 417, N° 5033-a | Equipo de clase II IEC 417, N° 5172-a | Corriente alterna trifásica IEC 617-2, N° 020206 | |
|  |  |  | |
| Precaución. Consulte los documentos adjuntos ISO 3864, N° B.3.1 | Precaución. Riesgo de descarga eléctrica ISO 3864, N° B.3.6 | Precaución. Superficie caliente IEC 417, N° 5041 | |

Tabla 4: Definición de los símbolos hallados en la unidad

Procedimientos y precauciones de seguridad

Las precauciones generales de seguridad descritas a continuación deben observarse durante todas las etapas de funcionamiento del instrumento. La falta de cumplimiento de dichas precauciones o de las advertencias específicas a las que se hace referencia en el manual, constituye una violación de las normas de seguridad establecidas para el uso previsto del instrumento y podría anular la protección proporcionada por el equipo. Si el cliente no cumple dichas precauciones y advertencias, MKS Instruments, Inc. no asume responsabilidad legal alguna.

NO UTILICE PIEZAS NO ORIGINALES O MODIFIQUE EL INSTRUMENTO

No instale piezas que no sean originales ni modifique el instrumento sin autorización. Para asegurar el correcto funcionamiento de todos los dispositivos de seguridad, envíe el instrumento al Centro de servicio y calibración de MKS toda vez que sea necesario repararlo o efectuar tareas de mantenimiento.

LAS REPARACIONES DEBEN SER EFECTUADAS ÚNICAMENTE POR TÉCNICOS AUTORIZADOS

Los operarios no deben intentar reemplazar los componentes o realizar tareas de ajuste en el interior del instrumento. Las tareas de mantenimiento o reparación deben ser realizadas únicamente por personal autorizado.

TENGA CUIDADO CUANDO TRABAJE CON MATERIALES TÓXICOS

Cuando se utilicen materiales tóxicos, es responsabilidad de los operarios tomar las medidas de seguridad correspondientes, purgar totalmente el instrumento cuando sea necesario y comprobar que el material utilizado sea compatible con los materiales del instrumento e inclusive, con todos los materiales de sellado.

PURGUE EL INSTRUMENTO

Una vez instalada la unidad o antes de retirarla del sistema, purgue completamente la unidad con gas limpio y seco para eliminar todo resto de la sustancia líquida empleada anteriormente.

USE PROCEDIMIENTOS ADECUADOS PARA REALIZAR LA PURGA

El instrumento debe purgarse debajo de una campana de ventilación y deben utilizarse guantes protectores.

NO HAGA FUNCIONAR EL INSTRUMENTO EN AMBIENTES CON RIESGO DE EXPLOSIÓN

Para evitar que se produzcan explosiones, no haga funcionar este instrumento en un ambiente con riesgo de explosiones, excepto cuando el mismo haya sido certificado específicamente para tal uso.

USE ACCESORIOS ADECUADOS Y REALICE CORRECTAMENTE LOS PROCEDIMIENTOS DE AJUSTE

Todos los accesorios del instrumento deben cumplir las especificaciones del mismo y ser compatibles con el uso que se debe dar al instrumento. Arme y ajuste los accesorios de acuerdo con las instrucciones del fabricante.

COMPRUEBE QUE LAS CONEXIONES SEAN A PRUEBA DE FUGAS

Inspeccione cuidadosamente las conexiones de los componentes de vacío para comprobar que hayan sido instalados a prueba de fugas.

HAGA FUNCIONAR EL INSTRUMENTO CON PRESIONES DE ENTRADA SEGURAS

No haga funcionar nunca el instrumento con presiones superiores a la máxima presión nominal (en las especificaciones del instrumento hallará la presión máxima permitida).

INSTALE UNA CÁPSULA DE SEGURIDAD ADECUADA

Cuando el instrumento funcione con una fuente de gas presurizado, instale una cápsula de seguridad adecuada en el sistema de vacío para evitar que se produzcan explosiones cuando suba la presión del sistema.

MANTENGA LA UNIDAD LIBRE DE CONTAMINANTES

No permita el ingreso de contaminantes en la unidad antes o durante su uso. Los productos contaminantes tales como polvo, suciedad, pelusa, lascas de vidrio o virutas de metal pueden dañar irreparablemente la unidad o contaminar el proceso.

CALIENTE ADECUADAMENTE LAS UNIDADES CONTROLADAS POR MEDIO DE TEMPERATURA

Las unidades controladas por medio de temperatura funcionarán de acuerdo con las especificaciones sólo cuando se las caliente durante el tiempo suficiente para permitir que lleguen y se estabilicen a la temperatura de operación indicada. No calibre la unidad y no la ponga en cero hasta que finalice el procedimiento de calentamiento.

Chapter One: General Information

Introduction

The MKS Type 870B and 872B Micro-Baratron® Absolute Pressure Transducers are part of the MKS family of general purpose pressure transducers designed to provide accurate, reliable, and repeatable pressure measurements from 1000 Torr (≈ 20 psia) to 3000 psia. The 870 unit has a “single-ended” design (refer to Figure 1, page 25), and the 872 unit has a “flow-through” design (refer to Figure 3, page 27).

The 870/872 unit, designed for ultraclean gas delivery applications, offers the proven technology of the Baratron transducers in a considerably smaller package. The sensor exposes only Inconel® and Incoloy® to the process permitting use with corrosive, hazardous, or dirty gases and eliminating contamination of the process with transducer materials. Measurements are independent of gas composition. Using the latest single-sided, dual-electrode sensor design, coupled with a low impedance, fixed-frequency bridge signal conditioner, these instruments are capable of withstanding high overpressure conditions with minimal or no shifts in output over their range. The advanced bridge signal conditioning technology provides high accuracy and operation which is extremely temperature-stable at operating pressure.

The transducer provides an output signal that is proportional to pressure. The output, provided through a fixed cable with flying leads (with an optional attached connector) located on top of the unit, is either a DC voltage (0 to 10 V, 0 to 5 V) or mA current (4 to 20 mA). For a direct readout of the pressure measurement, a meter (analog or digital) is required.

The 870/872 transducer requires a power supply of 12 VDC (minimum) to 36 VDC (maximum), regulated to $\pm 5\%$. The specific power supply required depends on the output configuration of the transducer (refer to *Power Requirements*, page 22, for more information). The unit is available with a variety of fittings, is capable of measuring pressure at ambient temperatures of 0° to 50° C (32° to 122° F), and has an uncertainty of 1% of reading. There are two environmental options available: as a standard unit for indoor use, or as a weather resistant NEMA 4/4x compliant unit for outdoor use. The 870/872 transducer can be mounted in any position; it is fully functional regardless of its orientation.

Protection from RF interference and noisy electrical environments is increased by the use of a metal case, by internal design elements, and by the use of surge and ESD suppression networks and RFI filtering on all inputs and outputs. The 870/872 transducer meets the electromagnetic testing required for the European CE Mark when used with an overall metal braided shielded cable, properly grounded at both ends. The 870/872 transducer offers additional manufacturing advances that meet the requirements of ultraclean processing. Each transducer is manufactured in a Class 100 clean room environment and packaged in double sealed bags backfilled with clean, dry nitrogen gas. All wetted surfaces have less than a 5 μ inch Ra finish.

How This Manual is Organized

This manual is designed to provide instructions on how to set up, install, and operate a Type 870/872 unit.

Before installing your Type 870/872 unit in a system and/or operating it, carefully read and familiarize yourself with all precautionary notes in the *Safety Messages and Procedures* section at the front of this manual. In addition, observe and obey all WARNING and CAUTION notes provided throughout the manual.

Chapter One, *General Information*, (this chapter) introduces the product and describes the organization of the manual.

Chapter Two, *Installation*, explains the environmental requirements and describes how to mount the instrument in your system.

Chapter Three, *Overview*, gives a brief description of the instrument and its functionality.

Chapter Four, *Operation*, describes how to use the instrument and explains all the functions and features.

Chapter Five, *Maintenance and Troubleshooting*, lists any maintenance required to keep the instrument in good working condition, and provides a checklist for reference should the instrument malfunction.

Appendix A, *Product Specifications*, lists the specifications of the instrument.

Appendix B, *Model Code Explanation*, describes the instrument's ordering code.

Customer Support

Standard maintenance and repair services are available at all of our regional MKS Calibration and Service Centers, listed on the back cover. Should any difficulties arise in the use of your Type 870/872 instrument, or to obtain information about companion products MKS offers, contact any authorized MKS Calibration and Service Center. If it is necessary to return the instrument to MKS, please obtain an ERA Number (Equipment Return Authorization Number) from the MKS Calibration and Service Center before shipping. The ERA Number expedites handling and ensures proper servicing of your instrument.

Please refer to the inside of the back cover of this manual for a list of MKS Calibration and Service Centers.

Warning



All returns to MKS Instruments must be free of harmful, corrosive, radioactive, or toxic materials.

Chapter Two: Installation

How To Unpack the Type 870/872 Unit

MKS has carefully packed the Type 870/872 unit so that it will reach you in perfect operating order. Upon receiving the unit, however, you should check for defects, cracks, broken connectors, etc., to be certain that damage has not occurred during shipment.

Note

Do *not* discard any packing materials until you have completed your inspection and are sure the unit arrived safely.

If you find any damage, notify your carrier and MKS immediately. If it is necessary to return the unit to MKS, obtain an ERA Number (Equipment Return Authorization Number) from the MKS Service Center before shipping. Please refer to the inside of the back cover of this manual for a list of MKS Calibration and Service Centers.

Ultraclean Units

The 870/872 transducer is an ultraclean unit that is assembled in a class 100 clean room environment. The unit is carefully purged with clean dry nitrogen and sealed to ensure maintenance of its particle free condition during shipment. It is very important to remove the bags according to clean room practices. To maintain at least a minimal level of clean room standards, follow the instructions below.

1. Remove the outer bag in an ante room (garmenting room) or transfer box.

Note

Do not allow this outer bag to enter the clean room.

2. Remove the inner bag in the clean room.

Unpacking Checklist

Standard Equipment:

- Type 870/872 Unit
- Type 870/872 Instruction Manual (this book)

Optional Equipment:

- Electrical Connector Accessories Kit (includes mating connectors for the connector option, should you choose to make your own interface cable):
 - 870A-K1
 - 872A-K1
- Interface cables (refer to Table 6, page 24)
- MKS Local Display Module (Type LDM)

Product Location and Requirements

Operating Temperature

The acceptable operating temperature for the 870/872 unit is 0° to 50° C (32° to 122° F).

Power Requirements

The 870/872 transducer requires a minimum power supply of 12 VDC and a maximum power supply of 36 VDC, regulated to $\pm 5\%$. The specific input power required depends on the output configuration of your unit, as listed in Table 5. The power is introduced to the 870/872 transducer through the connector attached to the cable on top of the unit.

| Power Requirements | | |
|-----------------------------|----------------------|--|
| Output Configuration | Output Signal | Input Power Requirement |
| Voltage | 0 to 5 V | +12 VDC to +32 VDC (regulated if below 13 VDC) @ 10 mA maximum |
| Voltage | 0 to 10 V | +13 VDC to +32 VDC @ 10 mA maximum |
| Current | 4 to 20 mA | +13 VDC to +36 VDC excitation (32 VDC maximum across the transducer) |

Table 5: Power Requirements

Interface Cables

As of January 1, 1996, most products shipped to the European Community must comply with the EMC Directive 89/336/EEC, which covers radio frequency emissions and immunity tests. In addition, as of January 1, 1997, some products shipped to the European Community must also comply with the Product Safety Directive 92/59/EEC and Low Voltage Directive 73/23/EEC, which cover general safety practices for design and workmanship. MKS products that meet these requirements are identified by application of the CE Mark.

To ensure compliance with EMC Directive 89/336/EEC, an overall metal braided shielded cable, properly grounded at both ends, is required during use. No additional installation requirements are necessary to ensure compliance with Directives 92/59/EEC and 73/23/EEC.

Note



1. Overall metal braided shielded cables, properly grounded at both ends, are required to meet CE specifications and are recommended if the environment contains high EMI/RFI noise.
2. To order metal braided shielded cables, add an “S” after the cable type designation. For example, to order a standard connection cable to connect the 870/872 unit to a 146 unit using a cable with a Bendix connector, use part number CB700-3-10; for a shielded cable, use part number CB700S-3-10.

The 870/872 transducer is compatible with most pressure, flow, flow ratio, and throttling valve controllers. Interface cables to connect the 870/872 unit to a MKS controller or power supply/readout can be purchased from MKS (refer to Table 6), or cables can be made provided that the appropriate specifications contained herein are maintained. For cables connecting to non-MKS products, MKS can provide normal shielding or braided shielded cable assemblies in a nominal 6' (1.8 m) or 10' (3 m) length, terminating in flying leads (pigtail) fashion at both ends.

| Interface Cables | | | |
|--|------------------|-----------------------------|-----------------|
| To Connect the 870/872 Unit To... | Connector | Use the MKS Cable... | |
| | | Standard | Shielded |
| 146, 186, 660 | Bendix | CB700-3-10 | CB700S-3-10 |
| | 9-pin Type “D” | CB700-1-10 | CB700S-1-10 |
| | 15-pin Type “D” | CB700-5-10 | CB700S-5-10 |
| PDR-C-1C/2C | Bendix | CB700-4-10 | CB700S-4-10 |
| | 9-pin Type “D” | CB700-2-10 | CB700S-2-10 |
| | 15-pin Type “D” | CB700-6-10 | CB700S-6-10 |

Table 6: Interface Cables

Generic Shielded Cables

MKS offers a full line of cables for all MKS equipment. Should you choose to manufacture your own cables, follow the guidelines listed below:

1. The cable must have an overall metal *braided* shield, covering all wires. Neither aluminum foil nor spiral shielding will be as effective; using either may nullify regulatory compliance.
2. The connectors must have a metal case which has direct contact to the cable's shield on the whole circumference of the cable. The inductance of a flying lead or wire from the shield to the connector will seriously degrade the shield's effectiveness. The shield should be grounded to the connector before its internal wires exit.
3. With very few exceptions, the connector(s) must make good contact to the device's case (ground). "Good contact" is about 0.01 ohms; and the ground should surround all wires. Contact to ground at just one point may not suffice.
4. For shielded cables with flying leads at one or both ends; it is important at each such end, to ground the shield *before* the wires exit. Make this ground with absolute minimum length. (A ¼ inch piece of #22 wire may be undesirably long since it has approximately 5 nH of inductance, equivalent to 31 ohms at 1000 MHz). After picking up the braid's ground, keep wires and braid flat against the case. With very few exceptions, grounded metal covers are not required over terminal strips. If one is required, it will be stated in the Declaration of Conformity or in the instruction manual.
5. In selecting the appropriate type and wire size for cables, consider:
 - A. The voltage ratings;
 - B. The cumulative I^2R heating of all the conductors (keep them safely cool);
 - C. The IR drop of the conductors, so that adequate power or signal voltage gets to the device;
 - D. The capacitance and inductance of cables which are handling fast signals, (such as data lines or stepper motor drive cables); and
 - E. That some cables may need internal shielding from specific wires to others; please see the instruction manual for details regarding this matter.

Setup

Dimensions

The diameter and height of the 870/872 transducer body are the same on all units. The *overall* height of the unit varies with each fitting, as shown in Figures 1 through 4, pages 25 to 28. The length of each fitting is measured from mating face to mating face.

Note  All dimensions are listed in inches with millimeters referenced in parentheses.

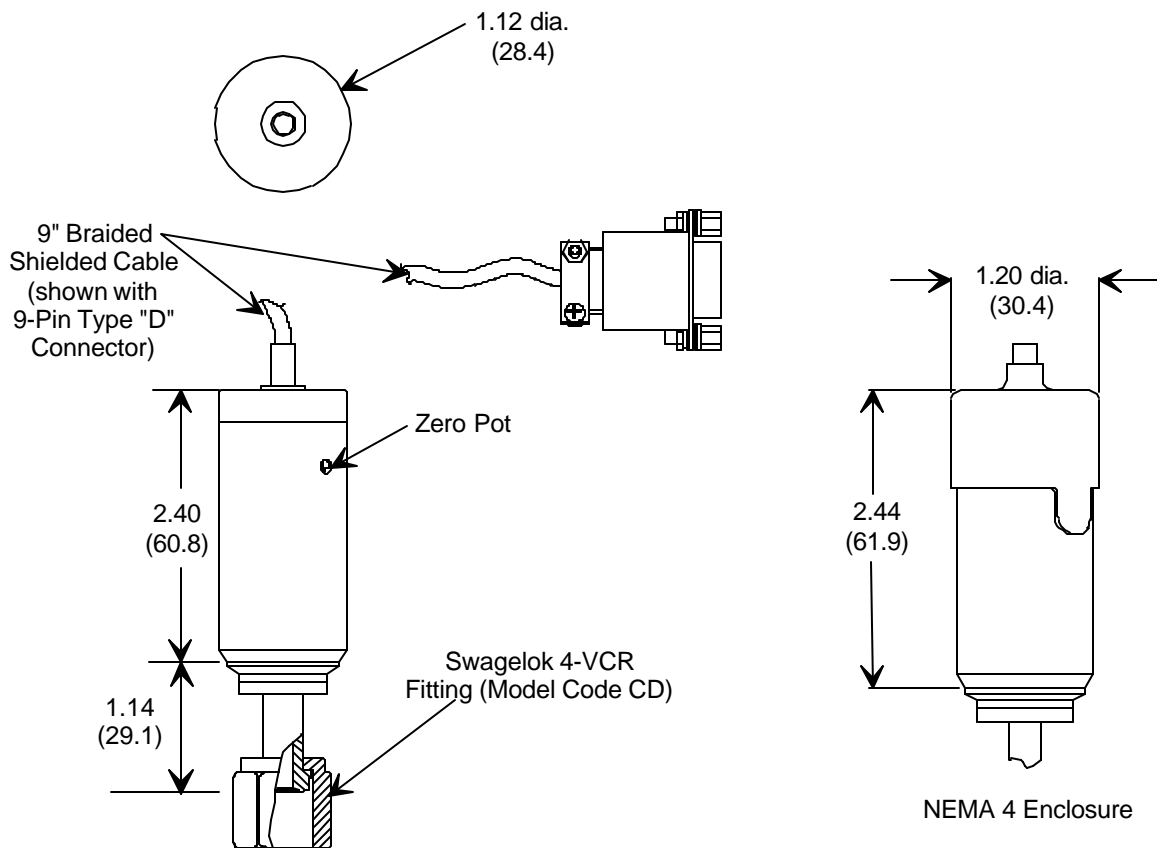

Figure 1: Dimensions of the Type 870 Transducer

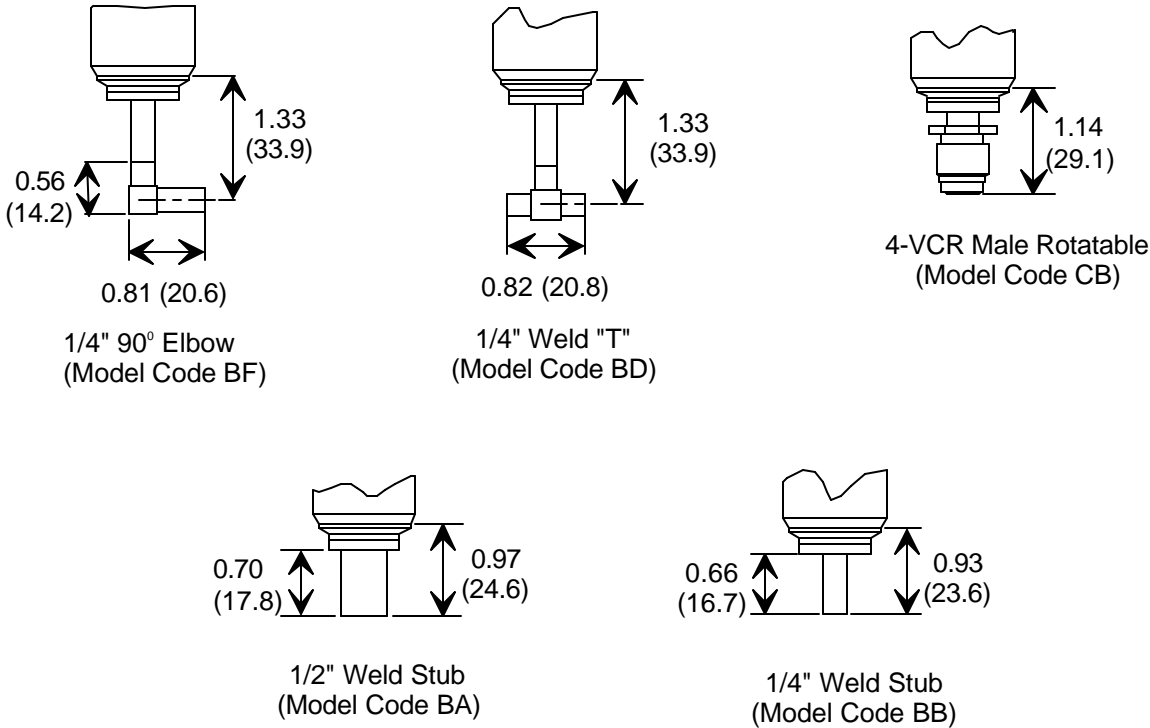

Figure 2: Dimensions of Additional Fittings for the Type 870 Transducer

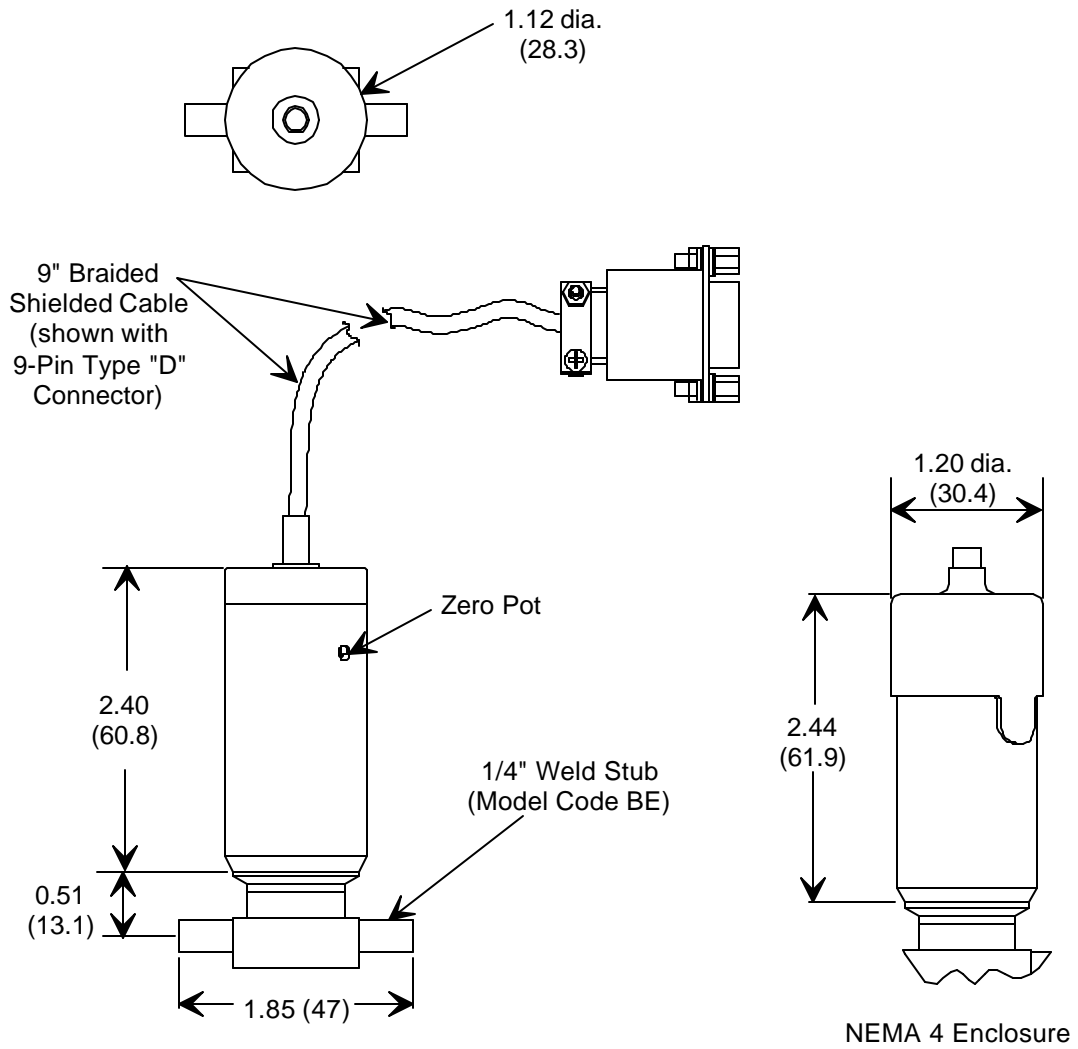

Figure 3: Dimensions of the Type 872 Transducer

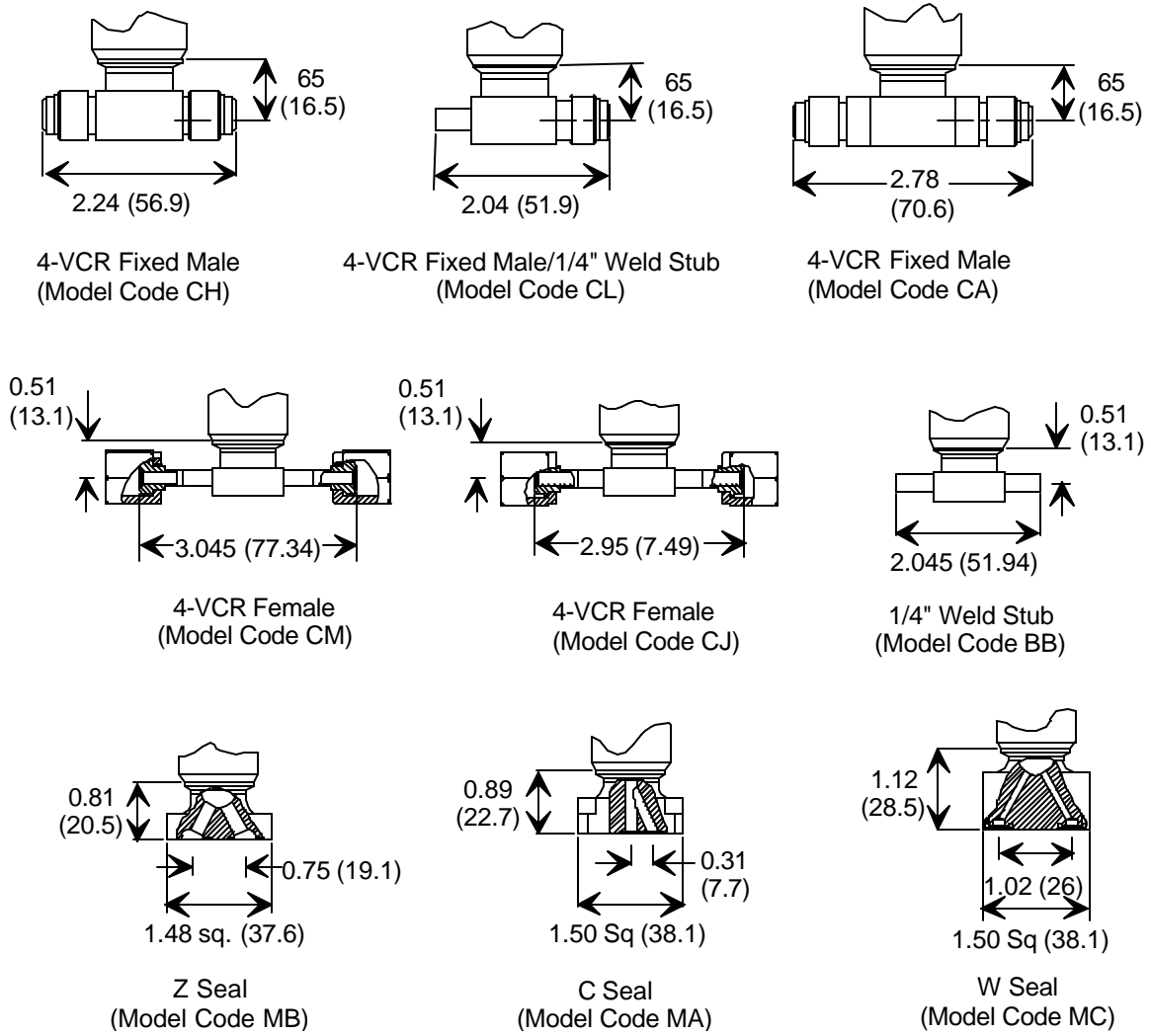

Figure 4: Dimensions of Additional Fittings for the Type 872 Transducer

Mounting Instructions

The 870/872 transducer can be mounted in any position; it is fully functional regardless of its orientation. When mounting the unit, be sure to consider accessibility to the user adjustable zero potentiometer, which is located on the side of the transducer. Refer to Figure 1, page 25 for the 870 unit. For the flow-through 872 unit, the zero pot is located 45° off the flow access. Refer to Figure 3, page 27.

Welded Connections

To weld a transducer in line to a system, you should follow certified welding practices, such as those published by the American Welding Society (AWS) or the American Society of Mechanical Engineers (ASME).

Warning

Improper welding can cause personal injury or damage equipment. Follow proper welding procedures at all times.

Mechanical Connections

To make mechanical connections in line to a system, use the recommended installation practices, as specified by the fitting manufacturer or by an appropriate standard. Tighten VCR fittings 1/8 turn past the finger tight position for 316 SS or nickel gaskets.

Warning

Improper installation can cause personal injury or damage equipment. Follow proper installation procedures at all times.

Electrical Information

Voltage Unit

The 870/872 transducer with a voltage output requires an external power source capable of supplying the voltages listed in Table 5, page 22. Noise and ripple should be less than 2 mV (peak-to-peak) over a 10 kHz bandwidth.

You may use any readout device capable of reading from -0.6 V to 11 V. Refer to Figure 5 for the power, signal, and chassis grounding scheme for a voltage unit.

Note



The ground of any external power supply and readout should be the same as the transducer ground (chassis ground) to minimize any possible ground loops and power supply noise which can affect the performance and stability of the system.

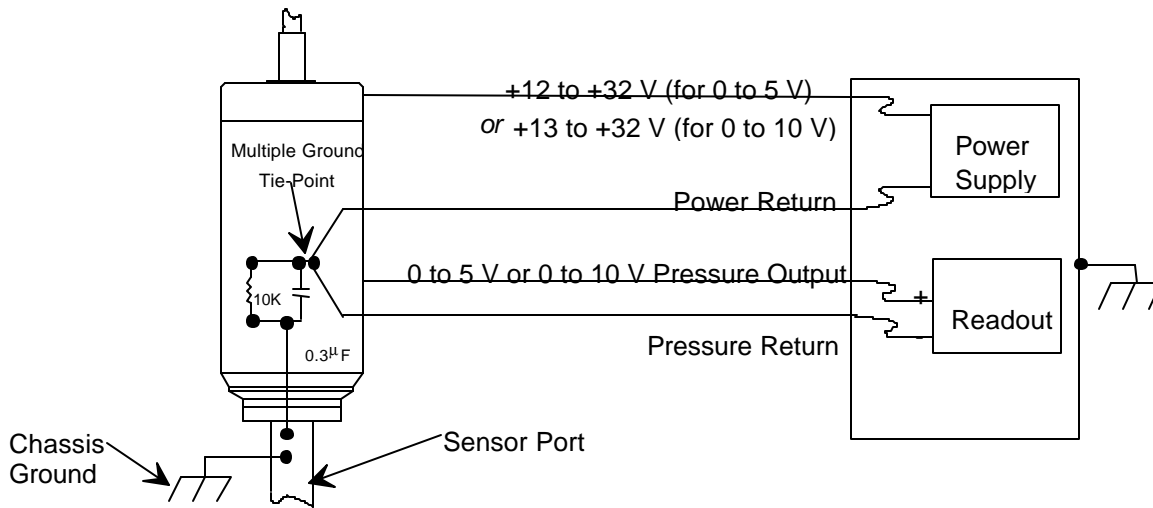

Figure 5: Electrical Scheme for a Voltage Unit

Current Unit

The 870/872 transducer with the 4 to 20 mA output requires an external power source capable of supplying the voltages listed in Table 5, page 22. Refer to Figure 8, page 32, for the electrical scheme for a current (4 to 20 mA) unit. Ordinary unshielded twisted pair transmission wire can be used for all connections.

The total external line resistance, including the sampling resistor, must not exceed the value R_{LN} determined by:

$$R_{LN} \text{ (ohms)} = \frac{(\text{Excitation Supply Volts} - 13) \times 10^3}{24}$$

Figure 6: Line Resistance Equation

For example, R_{LN} should not exceed 450 ohms for a 24 Volt supply.

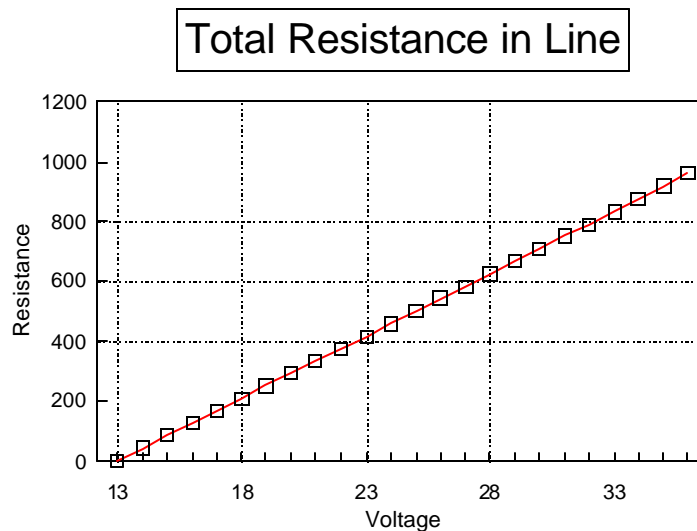

Figure 7: Total Resistance in Line

The maximum voltage between ground (sensor case) and the (-) terminal must not exceed 36 Volts for mA units. The maximum voltage between the positive (+) terminal and the (-) terminal must not exceed 32 Volts under any conditions.

Use the ZERO potentiometer to adjust the 4 mA setting (refer to *How To Adjust the Zero*, page 43). The ZERO pot is located on the side of the 870/872 unit (refer to Figure 1, page 25, and Figure 3, page 27).

Note



If the unit is considerably out of calibration, it may take more than one calibration cycle to accurately complete the zero adjustment.

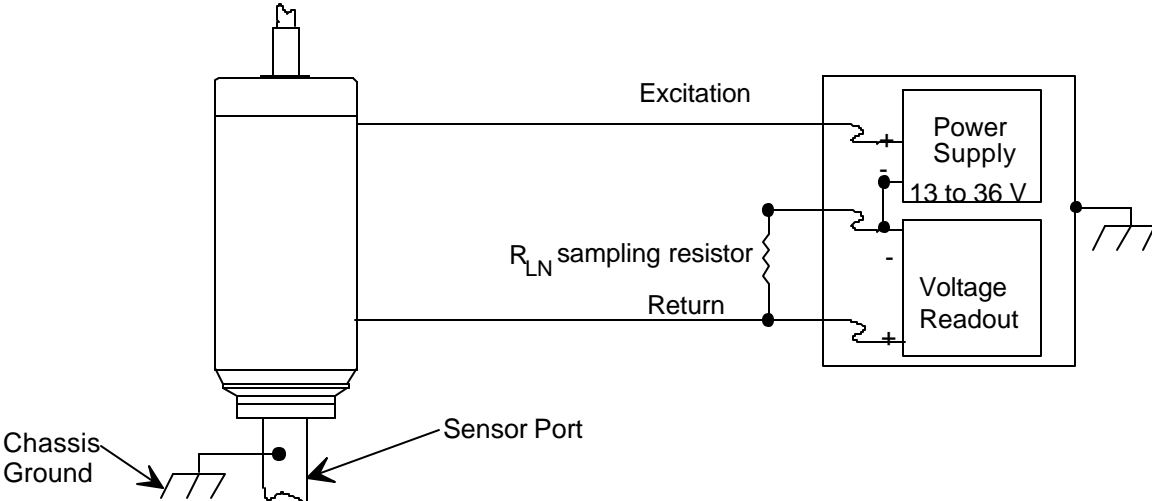

Figure 8: Electrical Scheme for a Current (4 to 20 mA) Unit

Connectors

The 870/872 unit has a fixed cable with a flying lead located on its top panel. The unit is available with just the flying lead, or with an optional Bendix or Type “D” connector attached to the flying lead (refer to Figure 1, page 25 and Figure 3, page 27). The length of the cable depends on the type of connector; the connector options are listed in Table 7.

| Connector Options | | |
|------------------------------|---------------------|--|
| Connector | Cable Length | Description |
| Flying Lead | 6' (1.8 m) | Green power, white return |
| Flying Lead | 10' (3 m) | Red power, black return |
| Bendix, 4-Pin PTO, male | 9" (225 mm) | 4 to 20 mA on pins A & D; voltage outputs on pins B & C |
| Bendix, 4-Pin PTO, male | 9" (225 mm) | 4 to 20 mA on pins A & D; pin B is jumpered to pin D |
| 9-Pin Standard Type “D” | 9" (225 mm) | Standard connector |
| 15-Pin High Density Type “D” | 9" (225 mm) | High Density connector |

Table 7: Connector Options

The pinouts for the connectors are listed in Tables 8 through 13, pages 34 to 37.

Note



The “Reserved” pin assignment refers to a pin that has an internal connection that may be assigned a function in the future.

Flying Leads

The 870/872 transducer is available with a flying lead at the end of either a 6' or 10' cable (refer to Figure 9). The two cable lengths have different configurations, as noted in Tables 8 and 9.

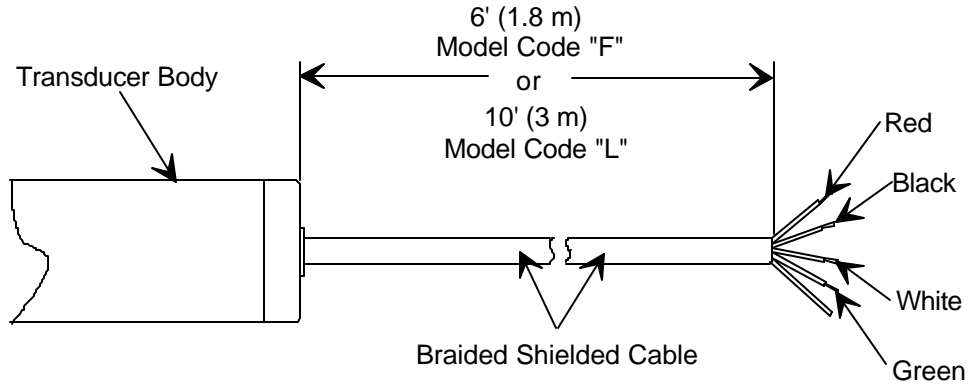

Figure 9: Flying Leads

Table 8 lists the pinout for the Flying Lead with a 6' (1.8 m) cable.

| Flying Lead Pinout (Model Code F) | | |
|-----------------------------------|-----------------|--------------------------------|
| Color | Voltage Signal | Current Signal |
| Red | Pressure Output | Do Not Use |
| Black | Pressure Return | Do Not Use |
| White | Power Return | 4 to 20 mA negative excitation |
| Green | + Power Input | 4 to 20 mA positive excitation |

Table 8: Flying Lead Pinout (Model Code F)

Table 9 lists the pinout for the Flying Lead with a 10'(3 m) cable.

| Flying Lead Pinout (Model Code L) | | |
|-----------------------------------|-----------------|--------------------------------|
| Color | Voltage Signal | Current Signal |
| Red | + Power Input | 4 to 20 mA positive excitation |
| Black | Power Return | 4 to 20 mA negative excitation |
| White | Pressure Return | Do Not Use |
| Green | Pressure Output | Do Not Use |

Table 9: Flying Lead Pinout (Model Code L)

Bendix Connectors

The 870/872 transducer is available with a Bendix connector attached to the flying lead at the end of the 9" cable (refer to Figure 10).

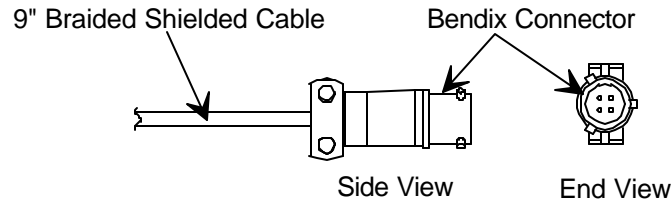

Figure 10: Bendix Connector

Warning



To prevent possible sparking, do not disconnect the Bendix connector while the circuit is live unless the area is known to be non-hazardous. There is a warning label on the cable (see Figure 15, page 41) for all units with a Bendix connector.

Table 10 lists the pinout for the Bendix 4 pin PTO, male connector (Model Code D).

| Bendix Connector Pinout (Model Code D) | | |
|---|-----------------------|--------------------------------|
| Pin | Voltage Signal | Current Signal |
| A | + Power Input | 4 to 20 mA positive excitation |
| B | Pressure Output | Do Not Use |
| C | Pressure Return | Do Not Use |
| D | Power Return | 4 to 20 mA negative excitation |

Table 10: Bendix Connector Pinout (Model Code D)

Table 11 lists the pinout for the configuration of the Bendix 4 pin PTO, male connector (Model Code H). This configuration is only available with the 4 to 20 mA output unit.

| Bendix Connector Pinout (Model Code H)* | |
|---|--------------------------------|
| Pin | Signal |
| A | 4 to 20 mA positive excitation |
| B | Jumpered to pin D |
| C | Reserved |
| D | 4 to 20 mA negative excitation |
| * This configuration is only available with the 4 to 20 mA output unit. | |

Table 11: Bendix Connector Pinout (Model Code H)

Type “D” Connectors

9-Pin Standard Type “D” Connector

The 870/872 transducer is available with a 9-pin male standard Type “D” connector attached to the flying lead at the end of the 9” cable (refer to Figure 11).

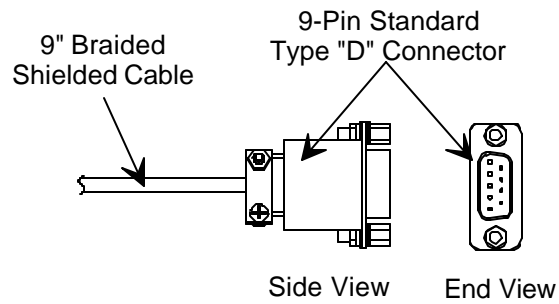

Figure 11: 9-Pin Standard Type “D” Connector

Table 12 lists the pinout for the 9-pin standard Type “D” connector.

| 9-Pin Standard Type “D” Connector Pinout | | |
|--|-----------------|--------------------------------|
| Pin | Voltage Signal | Current Signal |
| 1 | Pressure Output | Reserved |
| 2 | Reserved | Reserved |
| 3 | Reserved | Reserved |
| 4 | + Power Input | 4 to 20 mA positive excitation |
| 5 | Reserved | Reserved |
| 6 | Reserved | Reserved |
| 7 | Reserved | Reserved |
| 8 | Pressure Return | Reserved |
| 9 | Power Return | 4 to 20 mA negative excitation |

Table 12: 9-Pin Standard Type “D” Connector Pinout

15-Pin High Density Type “D” Connector

The 870/872 transducer is available with a 15-pin male high density Type “D” connector attached to the flying lead at the end of the 9” cable (refer to Figure 12).

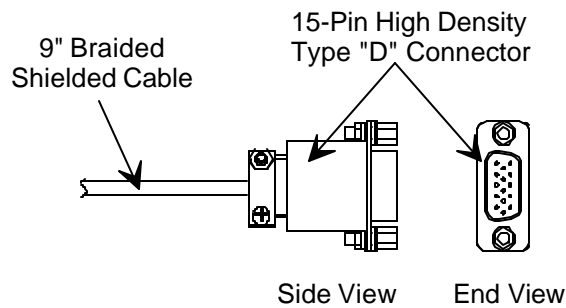

Figure 12: 15-Pin High Density Type “D” Connector

Table 13 lists the pinout for the 15-pin high density Type “D” connector.

| 15-Pin High Density Type “D” Connector Pinout | | |
|--|-----------------------|--------------------------------|
| Pin | Voltage Signal | Current Signal |
| 1 | Reserved | Reserved |
| 2 | Pressure Output | Reserved |
| 3 | Reserved | Reserved |
| 4 | Reserved | Reserved |
| 5 | Power Return | 4 to 20 mA negative excitation |
| 6 | Reserved | Reserved |
| 7 | + Power Input | 4 to 20 mA positive excitation |
| 8 | Reserved | Reserved |
| 9 | Reserved | Reserved |
| 10 | Reserved | Reserved |
| 11 | Reserved | Reserved |
| 12 | Pressure Return | Reserved |
| 13 | Reserved | Reserved |
| 14 | Reserved | Reserved |
| 15 | Reserved | Reserved |

Table 13: 15-Pin High Density Type “D” Connector Pinout

Startup

After installation, allow your transducer to warm up until it is stabilized, then check the transducer zero to verify the proper output. Refer to *How To Adjust the Zero*, page 43, for complete instructions on adjusting the ZERO potentiometer.

Note

The transducer must be *fully stabilized* before you make any adjustments to the ZERO pot.

Chapter Three: Overview

General Information

A complete pressure transducer system requires three components to convert pressure to a linear output: a sensor, signal conditioner, and power supply. The 870/872 transducer contains two of the required components: the sensor and signal conditioner.

An MKS or MKS-compatible power supply is required to complete the pressure to DC voltage or mA current conversion. For a direct readout of the pressure measurement, a meter (analog or digital) is required.

Sensor

The 870/872 transducer is a variable capacitance sensor consisting of a pressure inlet tube (port) connected to a small chamber in the transducer body. One wall of this chamber is a metal diaphragm. The front side of the diaphragm is exposed to the gas whose pressure is to be measured. The back, or *reference* side of the diaphragm faces a rigidly mounted ceramic disc containing two electrodes. The reference side is permanently evacuated below the resolution of the instrument.

The diaphragm in the single-ended version is positioned opposite the inlet port. The diaphragm on the flow-through version is positioned above the gas stream. The diaphragm, in either configuration, deflects with changing absolute pressure (force per unit area) independently of the gas type or composition of the measured gas. This deflection causes an imbalance of the sensor electrode capacitances since the distance to the diaphragm is now different for each electrode. Using a precision constant frequency oscillator for excitation, the imbalance of capacitances is converted to a DC voltage or mA current. The resultant signal is linearized, zeroed, and amplified via the signal conditioner electronics to produce a precise output signal scaled to the range of the transducer. The output signal, which is proportional to pressure, is provided through the connector on the top of the unit, as either a 0 to 10 V or 0 to 5 V DC voltage, or a 4 to 20 mA current.

Signal Conditioner

The signal conditioner contains state-of-the-art balanced bridge circuitry, self-compensated for thermal stability with ambient temperature changes. The circuit board construction uses surface mount technology. The output is either a DC voltage or mA current, which is linear with pressure. The transducer is then calibrated against a transfer standard to provide the selected output over the range of the transducer.

Labels

Serial Number Label

The serial number label, located on the transducer body, lists the unit's serial number, model number, input power requirement, and full scale range.



Figure 13: Serial Number Label

The options for your transducer are identified in the model code when you order the unit. Refer to *Appendix B: Model Code Explanation*, page 53, for more information.

Information Label

This label lists the maximum ambient temperature for the transducer and calls out the location of the zero pot. For 4 to 20 mA units, the label specifies that the 870/872 transducer is approved for use as a nonincendive device in Class I, Division 2, Groups A, B, C, & D hazardous locations per the Factory Mutual standard FM3611-1986. Under normal conditions, nonincendive devices are incapable of causing ignition of flammable or combustible material in air.

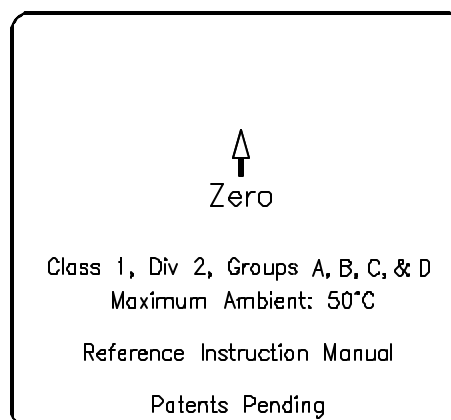

Figure 14: Information Label
(showing nonincendive device information for 4 to 20 mA unit)

Bendix Connector Warning Label

This warning label is attached to the fixed 9” cable located on top of the unit *only* when a Bendix connector is attached to the flying lead. To prevent possible sparking, never disconnect the Bendix connector while the circuit is live unless the area is known to be non-hazardous. Refer to *Bendix Connectors*, page 35, for more information.

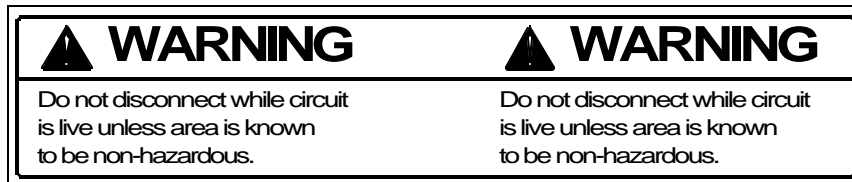

Figure 15: Bendix Connector Warning Label

This page intentionally left blank.

Chapter Four: Operation

How To Adjust the Zero

All pressure transducers require initial and periodic zero adjustments. Prior to initial operation and during periodic maintenance you must check the transducer zero to verify the proper output. The zero can be set (or reset) by adjusting the ZERO potentiometer on the side of the transducer (refer to Figure 1, page 25, and Figure 3, page 27) or at the front panel of any MKS Power Supply/Readout being used.

To achieve the full dynamic range specified for the transducer, the zero adjustment *must* be made at a pressure one decade lower than the transducer's minimum resolution (0.001% of FS). Zeroing a transducer above its stated minimum resolution creates a *zero offset* relative to true absolute pressure. All subsequent readings are then linear and accurate *relative to the offset value*.

Note

If available pressures are not sufficiently low to set the transducer zero, you may use a vacuum leak detector with sufficient vacuum pumping (to achieve proper zeroing pressures). In this case, mount the transducer on the leak detector *in the same plane of orientation as it will be during actual use*.

To properly zero the 870/872 transducer:

1. Install the 870/872 transducer in a system and connect a power supply/readout.
2. Power the transducer and allow it to stabilize.

Note  Ensure that the transducer is *fully stabilized* before you adjust the zero.

3. Pump the unit down to a pressure one decade below its resolution (0.001% of FS).

For best results, pump the transducer while it is warming up. Refer to Table 14 for the highest recommended pressure levels for proper zero adjustment.

| Highest Pressures Suggested for Proper Zero Adjustment | |
|---|--|
| Full Scale Range | Highest Pressure for Proper Zero Adjustment |
| 1000 Torr | 0.010 Torr |
| 100 psia | 0.0010 psia |
| 250 psia | 0.0025 psia |
| 1000 psia | 0.0100 psia |
| 3000 psia | 0.0300 psia |

Table 14: Highest Pressures Suggested for Proper Zero Adjustment

4. Adjust the ZERO pot with a small flathead screwdriver until the readout displays zero (0000).

The ZERO pot is located on the side of the transducer body (refer to Figure 1, page 25, and Figure 3, page 27).

Note  In 4 to 20 mA units, the ZERO pot adjusts the 4 mA setting.

Chapter Five: Maintenance and Troubleshooting

General Information

If the transducer fails to operate properly upon receipt, check for shipping damage, and check the cables for correct continuity. Any damage should be reported to the carrier and MKS Instruments immediately.

If there is no obvious damage and the cable continuity is correct, check your instrument using the troubleshooting chart (refer to Table 15, page 47). If the transducer performance does not improve and it is necessary to return the unit to MKS for service, obtain an ERA Number (Equipment Return Authorization Number) from any MKS Calibration and Service center before shipping. Please refer to the inside back cover of this manual for a list of MKS Calibration and Service Centers.

Maintenance

In general, no maintenance is required other than proper installation and operation, and an occasional zero adjustment. Periodically check for wear on the cables and inspect the enclosure for visible signs of damage.

Zero Adjustment

The transducer zero can be set (or reset) by adjusting the ZERO potentiometer located on the side of the unit or at the front panel of any MKS Power Supply/Readout being used. Refer to *How To Adjust the Zero*, page 43, for complete instructions on how to adjust the transducer zero.

Note

In production operations such as semiconductor manufacturing, verify the transducer zero (and adjust if necessary) each time the equipment is shut down for routine maintenance.

Troubleshooting

| Troubleshooting Chart | | |
|--|--|---|
| Failure Symptom | Possible Cause | Solution |
| <p>Output Signal "Stuck" - no response from panel.</p> <p>Transducer will not Zero or Span.</p> <p>Overrange Positive or Negative Output signal.</p> | <p>Transducer Sensor Element internally shorted</p> | <p>Perform continuity check on Sensor Electrodes as follows; Remove the electronics assembly from the sensor element. Locate the two electrode pins on the "top" of the sensor element. Using an Ohm Meter, check for resistance between each electrode pin and the sensor element body. If there is a reading less than infinity (open) then the sensor element is internally shorted and the Transducer must be replaced. Typical readings for defective sensors are less than 1000 Ohms, however higher resistances can still indicate a problem. If no continuity is present (infinite resistance) then sensor element is OK, refer to next possible cause or return the Transducer to the MKS factory for service.</p> |
| <p>Output Signal "Stuck" - no response from panel.</p> <p>Transducer will not Zero or Span.</p> | <p>Broken Ground connection between the PWA and the Sensor Element.</p> | <p>Remove the enclosure and inspect the three soldered connections where the PWA is mounted to the "chassis". One or more of these solder joints may be broken, or the solder pin may be broken off the chassis. If either situation is present the electronics assembly must be replaced. If not, refer to next possible cause or return the Transducer to the MKS factory for service.</p> |
| <p>Output Signal "Stuck" - no response from panel.</p> <p>Transducer will not Zero or Span.</p> <p>Overrange Positive or Negative Output signal.</p> | <p>Internal cable assembly connecting the PWA to the I/O connector is loose or broken.</p> | <p>Remove the enclosure and inspect the internal cable assembly at both ends. If a loose or broken wire or crimp is present then the cable assembly must be replaced. If not, refer to next possible cause or return the Transducer to the MKS factory for service.</p> |
| <p>Transducer will not Zero or Span.</p> | <p>Factory Coarse Zero adjustment is not properly centered.</p> | <p>Remove Transducer from service and return to MKS factory for repair.</p> |
| <p>Measurement slowly goes positive over time.</p> | <p>Transducer has seen Overpressure conditions.</p> | <p>Remove Transducer from service and return to MKS factory for repair.</p> |

| | | |
|---|--|--|
| Measurement slowly goes positive over time. | Buildup of contamination in the Px cavity. | Remove Transducer from service and return to MKS factory for repair. |
| Unstable output at zero pressure. | Excessive ambient temperature or ambient temp is varying over a very wide range. | Measure the ambient temperature and assure that it is within the specified operating range of the Transducer. If ambient temp. is within specifications, return the Transducer to the MKS factory for service. |

Table 15: Troubleshooting Chart

This page intentionally left blank.

Appendix A: Product Specifications

Performance Specifications

| | | |
|-------------------------|-----------------------------|------------------------|
| Accuracy | 1% of Reading | |
| Drift | < 50 psia | ≥ 50 to 3000 psia |
| Short Term | < 0.04% FS / day | < 0.02% FS / day |
| Long Term | ±0.12% F.S. / 6 months | ±0.06% F.S. / 6 months |
| Leak Rate | | |
| Inboard | 10 ⁻⁹ scc/sec He | |
| Outboard | < 1 ppm above background | |
| Sensor Response Time | < 0.1 msec calculated | |
| Temperature Coefficient | < 50 psia | ≥ 50 to 3000 psia |
| Zero | 0.04% of FS/°C | 0.02% of FS/°C |
| Span | 0.08% of Reading/°C | 0.04% of Reading/°C |

Electrical Specifications

| | |
|--|---|
| CE Compliance ¹ | EMC Directive 89/336/EEC |
| Input Power Requirement | 12 VDC minimum to 36 VDC maximum, regulated to ± 5% (dependent on output configuration) |
| 0 to 5 V Output | +12 VDC to +32 VDC ±5% (regulated if below 13 VDC) @ 10 mA maximum |
| 0 to 10 V Output | +13 VDC to +32 VDC ±5% @ 10 mA maximum |
| Two wire; 4 to 20 mA Output | +13 VDC to +36 VDC excitation (32 VDC maximum across the transducer) |
| Output | |
| 0 to 5 VDC | into >10 K ohm load |
| 0 to 10 VDC | into >10 K ohm load |
| Two wire 4 to 20 mA with +13 to +36 VDC excitation | into 0 to 900 ohm load (depending on excitation) |

¹ An overall metal braided shielded cable, properly grounded at both ends, is required during use.

| | |
|-------------------------|--|
| Reverse Wire Protection | Immune to reverse power wiring effects |
|-------------------------|--|

Physical Specifications

| | |
|---|---|
| Attitude (Orientation) Sensitivity | Fully functional without regard to operating orientation < 0.15% of reading per 180° of rotation |
| Burst Pressure 1000 Torr to 100 psi 101 to 3000 psi | 10 times full scale 5 times full scale |
| Configuration Type 870 Type 872 | Single-ended Flow-through |
| Connectors | 6' or 10' Flying Lead 4-Pin male PTO Bendix (2 configurations) at the end of a 9" flying lead 9-Pin standard or 15-pin high density male Type "D" at the end of a 9" flying lead |
| Fittings Type 870 Type 872 | ½" Tube Stub ¼" Weld Stub Swagelok® 4-VCR® male, rotatable 4-VCR female ¼" Butt Welded "T" ¼" Weld Stub (2 lengths) 4-VCR male, non-rotatable (2 lengths) 4-VCR female, rotatable 4-VCR female, non-rotatable 4-VCR male, non-rotatable / ¼" Tube stub |
| Full Scale Pressure Ranges | 1000 Torr, 60 psia, 100 psia, 250 psia, 1000 psia, 3000 psia |
| Internal Volume Type 870 Type 872 | < 1.0 cc < 2.0 cc |
| Materials Exposed to Gas Wetted Surfaces | Inconel/Incoloy, polished and passivated < 5 µinch (<0.125 µm) Ra, maximum |
| Nonincendive Device Approval | FM3611-1986; Class I, Division 2, Groups A, B, C, & D |

| | |
|---|--|
| Overpressure Limit 1000 Torr to 500 psi 501 to 3000 psi | 1.5 times full scale 1.2 times full scale |
| Weight (any configuration) | < 10 oz. (284 g) |
| Zero Adjustment Access | Located on the side of the unit; 45° from flow direction |

Environmental Specifications

| | |
|-----------------------------|--|
| Environmental Options | Standard unit (indoor use) NEMA 4 compliant unit (outdoor use; weather resistant) |
| Operating Humidity Range | 25 to 80% relative humidity, non-condensing |
| Operating Temperature Range | 0° to 50° C (32° to 122° F) |

Due to continuing research and development activities, these product specifications are subject to change without notice.

This page intentionally left blank.

Appendix B: Model Code Explanation

Model Code

The options for your transducer are identified in the model code when you order the unit. All parts of the model code apply to both the 870 and 872 units, except where noted.

The model code is identified as follows:

XXX YY W G Z E

where:

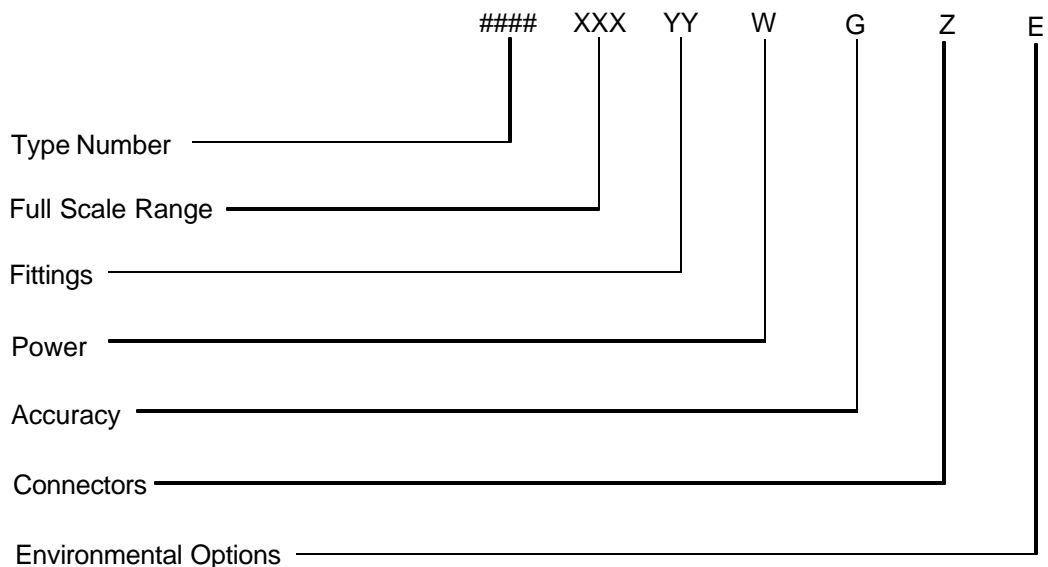

Type Number (####)

The type number designates the model number of the instrument. The 870B represents the single ended transducer; the 872B represents the flow-through transducer.

For Example: 872B12PCJ2GC1 describes a flow through Pressure Transducer, 100 psia, 4-VCR female rotatable fittings, 0-10 VDC output, 1% of reading uncertainty, 15 pin high density “D” connector for indoor use.

Full Scale Range (XXX)

The full scale range is indicated by a three character code.

| <i>Full Scale Range</i> | <i>Ordering Code</i> |
|-------------------------|----------------------|
| 1000 Torr | 13T |
| 60 psia | 61P |
| 100 psia | 12P |
| 250 psia | RDP |
| 1000 psia | 13P |
| 3000 psia | 33P |

Fittings (YY)

Several fittings are available, designated by a two letter code.

| <i>Fittings</i> | <i>Ordering Code</i> |
|--|----------------------|
| <i>Type 870 Single-Ended Design</i> | |
| ½" Tube Stub | BA |
| ¼" Weld Stub | BB |
| Swagelok® 4-VCR male, rotatable | CB |
| 4-VCR female | CD |
| ¼" Butt Welded "T" | BD |
| 0.876 face-to-face on the flow through part of the "T" | |
| <i>Type 872 Flow-Through Design</i> | |
| ¼" Weld Stub: | |
| 2.045" face-to-face flow through | BB |
| 1.85" face-to-face flow through | BE |
| 4-VCR male, non-rotatable: | |
| 2.78" face-to-face flow through | CA |
| 2.24" face-to-face flow through | CH |
| 4-VCR female, rotatable; | CJ |
| 2.95" face-to-face flow through | |
| 4-VCR female, non-rotatable; | CM |
| 3.045" face-to-face flow through | |
| 4-VCR male, non-rotatable / ¼" Tube Stub | CL |

Power (W)

The input/output power is designated by a single number code.

| <i>Power</i> | <i>Ordering Code</i> |
|---|----------------------|
| +13 to +32 VDC input / 0 to 10 VDC output | 2 |
| +12 to +32 VDC input / 0 to 5 VDC output | 3 |
| +13 to +36 VDC excitation / 4 to 20 mA output | 4 |

Accuracy (G)

The accuracy is designated by a single letter code.

| <i>Accuracy</i> | <i>Ordering Code</i> |
|------------------|----------------------|
| 1.00% of Reading | G |

Connectors (Z)

Six types of connectors are available, indicated by a single letter code.

| <i>Connector</i> | <i>Ordering Code</i> |
|---|----------------------|
| Flying Lead with 6' (1.8 m) Cable (White power, green return) | F |
| Flying Lead with 10' (3 m) Cable (Red power, black return) | L |
| Bendix 4-Pin PTO, male 4 to 20 mA on pins A & D; voltage outputs on pins B & C | D |
| Bendix 4-Pin PTO, male Pins A & B jumpered to pin D in 4 to 20 mA | H |
| 9-Pin Standard Type "D" | A |
| 15-Pin High Density Type "D" | C |

Environmental Options (E)

Two environmental options are available, indicated by a single number code.

| <i>Option</i> | <i>Ordering Code</i> |
|---|----------------------|
| Standard unit (indoor use) | 1 |
| NEMA 4/4X compliant unit (outdoor use; weather resistant) | 4 |

This page intentionally left blank.

Index

A

Accuracy, 55

B

Burst pressure, 50

C

Cables

 generic shielded, 24

 interface, 23

CE compliance, 49

Connections

 mechanical, 29

 welded, 29

Connectors, 50, 55

 Bendix, 35

 flying leads, 34

 Type "D", 36–37

Customer support, 20

E

Electrical information, 30–32, 55

Enclosure, 19, 55

F

Full scale range, 50, 54

I

Input power, 22

Introduction, 19

L

Labels

 nonincendive device, 40

 serial number, 40

 warning, 41

Line resistance, 31

M

Manual organization, 20

Model code, 40, 53

Mounting instructions, 19, 29

N

NEMA 4/4X, 19, 55

O

Operation

 zero adjustment, 43

P

Power, 55

Power requirements, 22, 49

R

Readout device, 30, 39

Returning the product, 20, 21, 45

Rln. See Line resistance

S

Safety information, 2–17

Sensor operation, 39

Serial number label, 40

Signal conditioner, 39

Startup

 pressures for proper zero adjustment, 44

 zero adjustment, 37–38

T

Temperature, operating, 22, 51

Troubleshooting, 47

U

Ultraclean processing, 19, 21

W

Warning label, Bendix connector, 41

Z

Zero adjustment, 37–38, 45