

136364-P1
Rev 3, 04/05

Type MC20A
High Flow Mass Flow Controller
with Analog I/O

Preliminary Copy

Copyright © 2005 by MKS Instruments, Inc.

All rights reserved. No part of this work may be reproduced or transmitted in any form or by any means, electronic or mechanical, including photocopying and recording, or by any information storage or retrieval system, except as may be expressly permitted in writing by MKS Instruments, Inc.

Printed in the United States of America

Baratron® and Mass-Flo® are registered trademarks of MKS Instruments, Inc., Andover, MA

Swagelok® and VCR® are registered trademarks of Swagelok Marketing Company, Solon, OH

Protected by U. S. Patents 5314164, 5461913, and 6505812.

Table of Contents

Mass Flow Controller Safety Information.....	1
Symbols Used in This Instruction Manual	1
Symbols Found on the Unit.....	1
Safety Procedures and Precautions.....	1
Sicherheitshinweise für das Massenflussgerät.....	3
In dieser Betriebsanleitung vorkommende Symbole	3
Erklärung der am Gerät angebrachten Symbole	3
Sicherheitsvorschriften und Vorsichtsmaßnahmen	3
Informations de sécurité pour appareils de mesure/contrôle de débit massique	5
Symboles utilisés dans ce manuel d'utilisation.....	5
Symboles figurant sur l'unité.....	5
Mesures de sécurité et précautions	5
Medidas de seguridad del dispositivo de flujo de masa	7
Símbolos usados en este manual de instrucciones.....	7
Símbolos hallados en la unidad	7
Procedimientos y precauciones de seguridad	7
マスフロー機器の安全に関する情報.....	9
本取扱説明書のマーク.....	9
本機器のマーク.....	9
安全対策について	9
질량 유량 장치 안전 정보	11
본 지침 매뉴얼에 사용되는 기호들	11
장치에 표시된 기호들	11
안전 절차 및 예방조치	11
Chapter One: General Information	13
Introduction	13
How This Manual is Organized.....	14
Customer Support.....	15
Chapter Two: Installation.....	17
How to Unpack the MC20A MFC	17
Product Location and Requirements.....	18
Setup.....	19
Electrical Connections.....	24
Interface Cables.....	26
Chapter Three: Overview	29
General Information	29
How the MC20A MFC Works	30
Overview of Digital Operation.....	30
Tuning the MC20A MFC	31
Chapter Four: Operation.....	35

How to Start the MC20A MFC	35
How to Zero the Flow Controller	35
How to Override the Valve.....	37
The Optional Input.....	37
Chapter Five: Maintenance	39
General Information	39
Zero Adjustment	39
Calibration	39
Chapter Six: Troubleshooting	41
Troubleshooting Chart.....	41
Description of Digital Error Messages	42
Appendix A: Product Specifications	45
Performance Specifications	45
Physical Specifications.....	46
Environmental Specifications.....	46
Appendix B: Gas Correction Factors	47
Explanation of Gas Correction Factor (GCF).....	47
Gas Correction Factors Table	48
Appendix C: Model Code Explanation.....	51
Model Code Description.....	51
Appendix D: Mass Flow Controller Sizing Guidelines	53
General Information	53
How to Determine the Flow Controller Range	53
Appendix E: MKS MC20A Digital MFC Graphical User Interface.....	55
Overview	55
Software Setup.....	55
Equipment Needed	56
Equipment Setup	56
Starting the GUI	57
Exiting the GUI	58
Description of the Main Control Panel.....	58
User Mode and Calibration Mode	59
Calibration Mode Access.....	60
Setting, Adding, and Deleting Gas Tables.....	62
Adjusting PID Tuning Parameters.....	66
Viewing Identity Table.....	67
Reading Diagnostic Messages	67
Creating and Modifying Calibration Tables	68
Index	71

List of Figures

Figure 1: Front View of the MC20A MFC with 4 VCR Fittings	20
Figure 2: Front View of the MC20A MFC with 8 VCR Fittings (includes required mounting plate)	20
Figure 3: Bottom View of the MC20A MFC with 4 VCR Fittings	21
Figure 4: Bottom View of the MC20A MFC with 8 VCR Fittings (includes required mounting plate)	21
Figure 5: Inlet End View of the MC20A MFC	22
Figure 6: Top View of the MC20A MFC with 15-Pin Analog Interface	22
Figure 7: Serial Number Label	23
Figure 8: Effects of the Proportional Term (Low Proportional Term)	32
Figure 9: Effects of the Proportional Term (High Proportional Term)	32
Figure 10: Effects of the Integral Term (Low Integral Term)	33
Figure 11: Effects of the Integral Term (High Integral Term)	33
Figure 12: Equipment Setup	56
Figure 13: Communications Window	57
Figure 14: MC20A MFC Main Control Panel	57
Figure 15: Change Password Window	60
Figure 16: Adding a Calibration Mode Password for a New User	61
Figure 17: Add/Select Gas	62
Figure 18: Accuracy Graphical Representation	64
Figure 19: Gas List	64
Figure 20: Copy Gas Table	65
Figure 21: Tuning Parameters	66
Figure 22: Identity Table	67
Figure 23: Calibration Table Operations	68

List of Tables

Table 1: Definition of Symbols Found on the Unit	1
Tabelle 2: Bedeutung der am Gerät angebrachten Symbole	3
Tableau 3: Définition des symboles sur l'unité.....	5
Tabla 4: Definición de los símbolos hallados en la unidad	7
표 6: 장치에 표시된 기호들의 정의	11
Table 7: 15-Pin Type “D” MFC Connector Pinout – Standard Assignments (Model Code B)	24
Table 8: 15-Pin Type “D” MFC Connector Pinout – Alternative Assignments (Model Code E).....	25
Table 9: MKS Interface Cables	26
Table 10: Troubleshooting Chart.....	41
Table 11: Description of Digital Error Messages	42
Table 12: Gas Correction Factors.....	48
Table 13: Summary of User and Calibration Mode Capabilities	59

Mass Flow Controller Safety Information

Symbols Used in This Instruction Manual

Definitions of WARNING, CAUTION, and NOTE messages used throughout the manual.



Warning

The **WARNING** sign denotes a hazard. It calls attention to a procedure, practice, condition, or the like, which, if not correctly performed or adhered to, could result in injury to personnel.



Caution

The **CAUTION** sign denotes a hazard. It calls attention to an operating procedure, practice, or the like, which, if not correctly performed or adhered to, could result in damage to or destruction of all or part of the product.















Note

The **NOTE** sign denotes important information. It calls attention to a procedure, practice, condition, or the like, which is essential to highlight.

Symbols Found on the Unit

The following table describes symbols that may be found on the unit.

Table 1: Definition of Symbols Found on the Unit

 On (Supply) IEC 417, No. 5007	 Off (Supply) IEC 417, No. 5008	 Earth (ground) IEC 417, No. 5017	 Protective Earth (ground) IEC 417, No. 5019
 Frame or Chassis IEC 417, No. 5020	 Equipotentiality IEC 417, No. 5021	 Direct Current IEC 417, No. 5031	 Alternating Current IEC 417, No. 5032
 Both Direct and Alternating Current IEC 417, No. 5033-a	 Class II Equipment IEC 417, No. 5172-a	 Three Phase Alternating Current IEC 617-2, No. 020206	
 Caution (refer to accompanying documents) ISO 3864, No. B.3.1	 Caution, Risk of Electric Shock ISO 3864, No. B.3.6	 Caution, Hot Surface IEC 417, No. 5041	

Safety Procedures and Precautions

Observe the following general safety precautions during all phases of operation of this instrument. Failure to comply with these precautions or with specific warnings elsewhere in this manual violates safety standards of intended use of the instrument and may impair the protection provided by the equipment. MKS Instruments, Inc. assumes no liability for the customer's failure to comply with these requirements.

DO NOT SUBSTITUTE PARTS OR MODIFY INSTRUMENT

Do not install substitute parts or perform any unauthorized modification to the instrument. Return the instrument to an MKS Calibration and Service Center for service and repair to ensure that all safety features are maintained.

SERVICE BY QUALIFIED PERSONNEL ONLY

Operating personnel must not remove instrument covers. Component replacement and internal adjustments must be made by qualified service personnel only.

KEEP AWAY FROM LIVE CIRCUITS

Do not replace components with power cable connected. Under certain conditions, dangerous voltages may exist even with the power cable removed. To avoid injuries, always disconnect power and discharge circuits before touching them.

USE PROPER PROCEDURES WHEN PURGING

This instrument must be purged under a ventilation hood, and gloves must be worn to protect personnel.

DO NOT OPERATE IN AN EXPLOSIVE ENVIRONMENT

To avoid explosion, do not operate this product in an explosive environment unless it has been specifically certified for such operation.

USE PROPER FITTINGS AND TIGHTENING PROCEDURES

All instrument fittings must be consistent with instrument specifications, and compatible with the intended use of the instrument. Assemble and tighten fittings according to manufacturer's directions.

CHECK FOR LEAK-TIGHT FITTINGS

Before proceeding to instrument setup, carefully check all plumbing connections to the instrument to ensure leak-tight installation.

OPERATE AT SAFE INLET PRESSURES

This unit should never be operated at pressures higher than the rated maximum pressure (refer to the product specifications for the maximum allowable pressure).

KEEP THE UNIT FREE OF CONTAMINANTS

Do not allow contaminants of any kind to enter the unit before or during use. Contamination such as dust, dirt, lint, glass chips, and metal chips may permanently damage the unit.

ALLOW PROPER WARM UP TIME FOR TEMPERATURE-CONTROLLED UNITS

Temperature-controlled unit will only meet specifications when sufficient time is allowed for the unit to meet, and stabilize at, the designed operating temperature. Do not zero or calibrate the unit until the warm up is complete.

Sicherheitshinweise für das Massenflussgerät

In dieser Betriebsanleitung vorkommende Symbole

Bedeutung der mit WARNUNG!, VORSICHT! und HINWEIS gekennzeichneten Absätze in dieser Betriebsanleitung.



Warnung!

Das Symbol **WARNUNG!** weist auf eine Gefahr für das Bedienpersonal hin. Es macht auf einen Arbeitsablauf, eine Arbeitsweise, einen Zustand oder eine sonstige Gegebenheit aufmerksam, deren unsachgemäße Ausführung bzw. ungenügende Berücksichtigung zu Verletzungen führen kann.



Vorsicht!

Das Symbol **VORSICHT!** weist auf eine Gefahr für das Gerät hin. Es macht auf einen Bedienungsablauf, eine Arbeitsweise oder eine sonstige Gegebenheit aufmerksam, deren unsachgemäße Ausführung bzw. ungenügende Berücksichtigung zu einer Beschädigung oder Zerstörung des Gerätes oder von Teilen des Gerätes führen kann.

















Hinweis

Das Symbol **HINWEIS** macht auf wichtige Informationen bezüglich eines Arbeitsablaufs, einer Arbeitsweise, eines Zustands oder einer sonstige Gegebenheit aufmerksam.

Erklärung der am Gerät angebrachten Symbole

Nachstehender Tabelle sind die Bedeutungen der Symbole zu entnehmen, die am Gerät angebracht sein können.

Tabelle 2: Bedeutung der am Gerät angebrachten Symbole

 Ein (Energie) IEC 417, No.5007	 Aus (Energie) IEC 417, No.5008	 Erdanschluss IEC 417, No.5017	 Schutzleiteranschluss IEC 417, No.5019
 Masseanschluss IEC 417, No.5020	 Aquipotentialanschluss IEC 417, No.5021	 Gleichstrom IEC 417, No.5031	 Wechselstrom IEC 417, No.5032
 Gleich- oder Wechselstrom IEC 417, No.5033-a	 Durchgängige doppelte oder verstärkte Isolierung IEC 417, No.5172-a	 Dreileiter-Wechselstrom (Drehstrom) IEC 617-2, No.020206	
 Warnung vor einer Gefahrenstelle (Achtung, Dokumentation beachten) ISO 3864, No.B.3.1	 Warnung vor gefährlicher elektrischer Spannung ISO 3864, No.B.3.6	 Höhere Temperatur an leicht zugänglichen Teilen IEC 417, No.5041	

Sicherheitsvorschriften und Vorsichtsmaßnahmen

Folgende allgemeine Sicherheitsvorschriften sind während allen Betriebsphasen dieses Gerätes zu befolgen. Eine Missachtung der Sicherheitsvorschriften und sonstiger Warnhinweise in dieser

Betriebsanleitung verletzt die für dieses Gerät und seine Bedienung geltenden Sicherheitsstandards, und kann die Schutzvorrichtungen an diesem Gerät wirkungslos machen. MKS Instruments, Inc. haftet nicht für Missachtung dieser Sicherheitsvorschriften seitens des Kunden.

Niemals Teile austauschen oder Änderungen am Gerät vornehmen!

Ersetzen Sie keine Teile mit baugleichen oder ähnlichen Teilen, und nehmen Sie keine eigenmächtigen Änderungen am Gerät vor. Schicken Sie das Gerät zwecks Wartung und Reparatur an den MKS-Kalibrierungs- und -Kundendienst ein. Nur so wird sichergestellt, dass alle Schutzvorrichtungen voll funktionsfähig bleiben.

Wartung nur durch qualifizierte Fachleute!

Das Auswechseln von Komponenten und das Vornehmen von internen Einstellungen darf nur von qualifizierten Fachleuten durchgeführt werden, niemals vom Bedienpersonal.

Vorsicht vor stromführenden Leitungen!

Ersetzen Sie keine Komponente von Geräten, die an Netzstrom angeschlossen sind. Unter Umständen kann gefährliche Spannung auch dann bestehen, wenn das Netzanschlusskabel von der Stromversorgung entfernt wurde. Um Verletzungen vorzubeugen sollten zuerst alle Geräte von der Stromversorgung getrennt und alle Stromkreisläufe entladen werden.

Anweisungen zum Spülen des Gerätes

Das Gerät darf nur unter einer Ablufthaube gespült werden. Schutzhandschuhe sind zu tragen.

Gerät nicht zusammen mit explosiven Stoffen, Gasen oder Dämpfen benutzen!

Um der Gefahr einer Explosion vorzubeugen, darf dieses Gerät niemals zusammen mit (oder in der Nähe von) explosiven Stoffen aller Art eingesetzt werden, sofern es nicht ausdrücklich für diesen Zweck zugelassen ist.

Anweisungen zum Installieren der Armaturen!

Alle Anschlussstücke und Armaturenteile müssen mit der Gerätespezifikation übereinstimmen, und mit dem geplanten Einsatz des Gerätes kompatibel sein. Der Einbau, insbesondere das Anziehen und Abdichten, muss gemäß den Anweisungen des Herstellers vorgenommen werden.

Verbindungen auf Undichtigkeiten prüfen!

Überprüfen Sie sorgfältig alle Verbindungen der Vakuumkomponenten auf undichte Stellen.

Gerät nur unter zulässigen Anschlussdrücken betreiben!

Betreiben Sie das Gerät niemals unter Drücken, die den maximal zulässigen Druck (siehe Produktspezifikationen) übersteigen.

Verunreinigungen im Gerät vermeiden!

Stellen Sie sicher, dass Verunreinigungen jeglicher Art weder vor dem Einsatz noch während des Betriebs in das Instrumenteninnere gelangen können. Staub- und Schmutzpartikel, Glassplitter oder Metallspäne können das Gerät dauerhaft beschädigen oder Prozess- und Messwerte verfälschen.

Bei Geräten mit Temperaturkontrolle korrekte Anwärmzeit einhalten!

Temperaturkontrollierte Geräte arbeiten nur dann gemäß ihrer Spezifikation, wenn genügend Zeit zum Erreichen und Stabilisieren der Betriebstemperatur eingeräumt wird. Kalibrierungen und Nulleinstellungen sollten daher nur nach Abschluss des Anwärmvorgangs durchgeführt werden.

Informations de sécurité pour appareils de mesure/contrôle de débit massique

Symboles utilisés dans ce manuel d'utilisation

Définitions des indications AVERTISSEMENT, ATTENTION, et REMARQUE utilisées dans ce manuel.



Avertissement

L'indication **AVERTISSEMENT** signale un danger pour le personnel. Elle attire l'attention sur une procédure, une pratique, une condition, ou toute autre situation présentant un risque d'accident pour le personnel, en cas d'exécution incorrecte ou de non-respect des consignes.



Attention

L'indication **ATTENTION** signale un danger pour l'appareil. Elle attire l'attention sur une procédure d'exploitation, une pratique, ou toute autre situation, présentant un risque de dégât ou de destruction partielle ou totale du produit, en cas d'exécution incorrecte ou de non-respect des consignes.

















Remarque

L'indication **REMARQUE** signale une information importante. Elle attire l'attention sur une procédure, une pratique, une condition, ou toute autre situation, présentant un intérêt particulier.

Symboles figurant sur l'unité

Le tableau suivant décrit les symboles pouvant apparaître sur l'unité.

Tableau 3: Définition des symboles sur l'unité

 Marche (sous tension) IEC 417, No.5007	 Arrêt (hors tension) IEC 417, No.5008	 Terre (masse) IEC 417, No.5017	 Terre de protection (masse) IEC 417, No.5019
 Masse IEC 417, No.5020	 Equipotentialité IEC 417, No.5021	 Courant continu IEC 417, No.5031	 Courant alternatif IEC 417, No.5032
 Courant continu et alternatif IEC 417, No.5033-a	 Matériel de classe II IEC 417, No.5172-a	 Courant alternatif triphasé IEC 617-2, No.020206	
 Attention : se reporter à la documentation ISO 3864, No.B.3.1	 Attention : risque de choc électrique ISO 3864, No.B.3.6	 Attention : surface brûlante IEC 417, No.5041	

Mesures de sécurité et précautions

Observer les précautions générales de sécurité suivantes pendant toutes les phases d'exploitation de cet appareil. Le non-respect des ces précautions ou des avertissements du manuel constitue une violation des normes de sécurité relatives à l'utilisation de l'appareil et peut compromettre la protection assurée

par l'appareil. MKS Instruments, Inc. rejette toute responsabilité en cas de non-respect des consignes par les clients.

PAS DE REMPLACEMENT DE PIÈCES OU DE MODIFICATION DE L'APPAREIL

Ne pas installer de pièces de remplacement ni effectuer des modifications non autorisées sur l'appareil. Renvoyer l'appareil à un centre de service et de calibrage MKS pour tout dépannage ou réparation afin de garantir le l'intégrité des dispositifs de sécurité.

DÉPANNAGE UNIQUEMENT PAR DU PERSONNEL QUALIFIÉ

Le personnel d'exploitation ne doit pas essayer de sortir les composants du boîtier ou faire des réglages internes. Le dépannage est réservé au personnel qualifié.

ÉLOIGNEMENT DES CIRCUITS SOUS-TENSION

Ne pas remplacer de composants lorsqu'un câble d'alimentation est branché. Dans certaines conditions, des tensions dangereuses peuvent être présentes même après le retrait du câble d'alimentation. Pour éliminer tout risque de blessure, procéder toujours à la déconnexion et décharger les circuits avant tout contact physique.

UTILISATION DES PROCÉDURES APPROPRIÉES POUR LA PURGE

Cet appareil doit être purgé sous une hotte de ventilation. Le personnel doit porter des gants de protection.

PAS D'EXPLOITATION DANS UN ENVIRONNEMENT EXPLOSIF

Pour éviter toute explosion, ne pas utiliser cet appareil dans un environnement explosif, sauf en cas d'homologation spécifique pour une telle exploitation.

UTILISATION D'ÉQUIPEMENTS ET PROCÉDURES DE SERRAGE APPROPRIÉS

Tous les équipements de l'appareil doivent être conformes à ses spécifications, et compatibles avec l'utilisation prévue de l'appareil. Assembler et serrer les équipements conformément aux directives du fabricant.

VÉRIFICATION DE L'ÉTANCHÉITÉ DES CONNEXIONS

Vérifier attentivement toutes les connexions des composants pour le vide afin de garantir l'étanchéité de l'installation.

EXPLOITATION AVEC DES PRESSIONS D'ENTRÉE NON DANGEREUSES

Ne jamais utiliser des pressions supérieures à la pression nominale maximum (se reporter aux spécifications de l'unité pour la pression maximum admissible).

MAINTIEN DE L'UNITÉ À L'ABRI DES CONTAMINATIONS

Ne pas laisser des produits contaminants pénétrer dans l'unité avant ou pendant l'utilisation. Des produits contaminants tels que des poussières et des fragments de tissu, de verre et de métal peuvent endommager l'unité de manière permanente.

RESPECT DU TEMPS D'ÉCHAUFFEMENT APPROPRIÉ POUR LES UNITÉS À RÉGULATION DE TEMPÉRATURE

Les unités à régulation de température sont conformes à leurs spécifications uniquement quand on leur laisse un temps suffisant pour atteindre d'une manière stable la température d'exploitation. Ne pas remettre à zéro ou calibrer l'unité tant que l'échauffement n'est pas terminé.

Medidas de seguridad del dispositivo de flujo de masa

Símbolos usados en este manual de instrucciones

Definiciones de los mensajes de advertencia, precaución y de las notas usados en el manual.



Advertencia

El símbolo de advertencia indica la posibilidad de que se produzcan daños personales. Pone de relieve un procedimiento, práctica, estado, etc. que en caso de no realizarse o cumplirse correctamente puede causar daños personales.



Precaución

El símbolo de precaución indica la posibilidad de producir daños al equipo. Pone de relieve un procedimiento operativo, práctica, etc. que en caso de no realizarse o cumplirse correctamente puede causar daños o la destrucción total o parcial del equipo.



Nota

El símbolo de notas indica información de importancia. Este símbolo pone de relieve un procedimiento, práctica o condición cuyo conocimiento es esencial destacar.

Símbolos hallados en la unidad

La tabla siguiente contiene los símbolos que puede hallar en la unidad.

Tabla 4: Definición de los símbolos hallados en la unidad

 Encendido (alimentación eléctrica) IEC 417, N° 5007	○ Apagado (alimentación eléctrica) IEC 417, N° 5008	⏏ Puesta a tierra IEC 417, N° 5017	⏏ Protección a tierra IEC 417, N° 5019
⏏ Caja o chasis IEC 417, N° 5020	⏏ Equipotencialidad IEC 417, N° 5021	≡ Corriente continua IEC 417, N° 5031	~ Corriente alterna IEC 417, N° 5032
~ Corriente continua y alterna IEC 417, N° 5033-a	□ Equipo de clase II IEC 417, N° 5172-a	3~ Corriente alterna trifásica IEC 617-2, N° 020206	
⚠ Precaución. Consulte los documentos adjuntos ISO 3864, N° B.3.1	⚡ Precaución. Riesgo de descarga eléctrica ISO 3864, N° B.3.6	🔥 Precaución. Superficie caliente IEC 417, N° 5041	

Procedimientos y precauciones de seguridad

Las medidas generales de seguridad descritas a continuación deben observarse durante todas las etapas de funcionamiento del instrumento. La falta de cumplimiento de dichas medidas de seguridad o de las advertencias específicas a las que se hace referencia en otras partes de este manual, constituye una violación de las normas de seguridad establecidas para el uso previsto del instrumento y podría anular

la protección proporcionada por el equipo. Si el cliente no cumple dichas precauciones y advertencias, MKS Instruments, Inc. no asume responsabilidad legal alguna.

NO UTILICE PIEZAS NO ORIGINALES O MODIFIQUE EL INSTRUMENTO

No instale piezas que no sean originales ni modifique el instrumento sin autorización. Para asegurar el correcto funcionamiento de todos los dispositivos de seguridad, envíe el instrumento al Centro de servicio y calibración de MKS toda vez que sea necesario repararlo o efectuar tareas de mantenimiento.

LAS REPARACIONES DEBEN SER EFECTUADAS ÚNICAMENTE POR TÉCNICOS AUTORIZADOS

Los operarios no deben retirar las tapas del instrumento. El reemplazo de los componentes y las tareas de ajuste deben ser realizadas únicamente por personal autorizado.

MANTÉNGASE ALEJADO DE LOS CIRCUITOS ACTIVOS

No reemplace componentes con el cable de alimentación eléctrica conectado. En algunos casos, puede haber presente alto voltaje aun con el cable de alimentación eléctrica desconectado. Para evitar lesiones personales, desconecte siempre el cable y descargue los circuitos antes de entrar en contacto con los mismos.

USE PROCEDIMIENTOS ADECUADOS PARA REALIZAR LA PURGA

El instrumento debe purgarse debajo de una campana de ventilación y deben utilizarse guantes protectores.

NO HAGA FUNCIONAR EL INSTRUMENTO EN AMBIENTES CON RIESGO DE EXPLOSIÓN

Para evitar que se produzcan explosiones, no haga funcionar este instrumento en un ambiente con riesgo de explosiones, excepto cuando el mismo haya sido certificado específicamente para tal uso.

USE ACCESORIOS ADECUADOS Y REALICE CORRECTAMENTE LOS PROCEDIMIENTOS DE AJUSTE

Todos los accesorios del instrumento deben cumplir las especificaciones del mismo y ser compatibles con el uso que se debe dar al instrumento. Arme y ajuste los accesorios de acuerdo con las instrucciones del fabricante.

COMPRUEBE QUE LOS ACCESORIOS SEAN A PRUEBA DE FUGAS

Antes de proceder con la instalación del instrumento, inspeccione cuidadosamente todas las conexiones de las tuberías para comprobar que hayan sido instaladas a prueba de fugas.

HAGA FUNCIONAR EL INSTRUMENTO CON PRESIONES DE ENTRADA SEGURAS

No haga funcionar nunca el instrumento con presiones superiores a la máxima presión nominal (en las especificaciones del instrumento hallará la presión máxima permitida).

MANTENGA LA UNIDAD LIBRE DE CONTAMINANTES

No permita el ingreso de contaminantes en la unidad antes o durante su uso. Los productos contaminantes tales como polvo, suciedad, pelusa, lascas de vidrio o virutas de metal pueden dañar irreparablemente la unidad.

CALIENTE ADECUADAMENTE LAS UNIDADES CONTROLADAS POR MEDIO DE TEMPERATURA

Las unidades controladas por medio de temperatura funcionarán de acuerdo con las especificaciones sólo cuando se las caliente durante el tiempo suficiente para permitir que lleguen y se estabilicen a la temperatura de operación indicada. No calibre la unidad y no la ponga en cero hasta que finalice el procedimiento de calentamiento.

マスフロー機器の安全に関する情報

本取扱説明書のマーク

本マニュアルでは警告、注意、ポイントのマークを用いて重要な事項を記載しています。



警告

この表示を無視して誤った取り扱い(手順や使用方法、条件など)をすると、人が重傷を負う可能性が想定される内容を示しています。必ずお読みください。



注意

この表示を無視して誤った取り扱い(手順や使用方法など)をすると、製品が損傷する可能性が想定される内容を示しています。必ずお読みください。



ポイント

この表示は手順や使用方法、条件などに関する重要な情報が記載されていることを示しています。必ずお読みください。

本機器のマーク

以下の表では、本機器に使用されているマークについて説明いたします。

 オン(電源) IEC 417, No. 5007	 オフ(電源) IEC 417, No. 5008	 接地(アース) IEC 417, No. 5017	 保護接地(アース) IEC 417, No. 5019
 フレームまたはシャーシ IEC 417, No. 5020	 等電位 IEC 417, No. 5021	 直流 IEC 417, No. 5031	 交流 IEC 417, No. 5032
 直流と交流 IEC 417, No. 5033-a	 クラス 2 機器 IEC 417, No. 5172-a	 三相交流 IEC 617-2, No. 020206	
 注意(付属書を参照) ISO 3864, No. B.3.1	 注意(感電の危険あり) ISO 3864, No. B.3.6	 注意(表面が熱くなっています) IEC 417, No. 5041	

安全対策について

本機器を使用する際は、必ず以下の安全対策を守ってください。これらの安全対策や本マニュアルの警告を無視すると、機器本来の用途の安全基準を侵害することになり、機器が提供する保護機能が損なわれる可能性があります。MKS Instruments, Inc. は、顧客側の安全対策の不履行に対しては一切責任を負いかねます。

勝手に部品を変えたり、本体を改造しないこと

本機器に代用部品を使用したり、不正な改造を加えないでください。すべての安全システムを正しく機能させるための修理やメンテナンスが必要な場合は、本機器を MKS Calibration and Service Center まで戻してください。

修理は必ず専門の修理サービスを利用すること

オペレータは絶対に本機器を分解しないでください。部品の交換や内部の調整は必ず専門の修理サービスを利用してください。

電流が通じている回路から切断すること

電源ケーブルを接続したままで部品を交換しないでください。特定の状況では、電源ケーブルを取り外した状態でも危険な電圧が残っている場合があります。感電などの事故を防ぐため、回路に触れる前に必ず電源から切断し、放電してください。

浄化する場合は適切な手順で行うこと

本機器の浄化は換気フードの下で行う必要があります。また、浄化作業を行う人は必ず手袋を着用してください。

爆発の危険性のある環境で機器を使用しないこと

爆発が起きるのを防ぐため、本機器を爆発の危険性のある環境で使用しないでください。ただし、そのような環境での使用が特別に保証されている場合は除きます。

適切な金具類を使用し、手順に従って金具の締めを行うこと

金具類は本機器の仕様と一致し、機器本来の用途に適合したものである必要があります。金具類の取り付けや締めは、製造業者の指示に従ってください。

液体の漏れがないよう接続箇所を確認すること

本機器を設定する前に、すべての配管の接続を慎重に確認し、液体が漏れないようにしてください。

安全なインレット圧力で使用すること

定格の最大圧力を超える圧力の下で本機器を絶対に使用しないでください(最大許容圧力については仕様書を参照)。

本機器に異物やゴミが混入しないようにすること

本機器の使用前または使用中に、ほこりやゴミ、繊維、ガラスの破片、金属片などの異物やゴミが混入しないようにしてください。本機器が損傷する可能性があります。

温度調整された機器を十分に温めてから使用すること

温度調整された機器が適切な作動温度にならないうちに使用すると、仕様通りの動作をしないことがあります。本機器が十分に温まるまでは目盛りをゼロに合わせたり、校正しないでください。

질량 유량 장치 안전 정보

본 지침 매뉴얼에 사용되는 기호들

매뉴얼 전체에 사용되는 경고, 주의 및 참고 메시지의 정의.



경고

경고 표시는 위험을 나타냅니다. 이 표시는 올바르게 수행되거나 지켜지지 않을 경우, 사람에게 상해를 입힐 수 있는 절차, 수행지침, 상태 또는 이와 유사한 상황들에 대한 주의를 환기시킵니다.



주의

주의 표시는 위험을 나타냅니다. 이 표시는 올바르게 수행되거나 지켜지지 않을 경우, 제품의 일부나 전체에 손상이나 파손을 일으킬 수 있는 절차, 수행지침 또는 이와 유사한 상황들에 대한 주의를 환기시킵니다.

















참고

참고 표시는 중요한 정보를 나타냅니다. 이 표시는 강조할 만한 주요 절차, 수행지침, 상태 또는 이와 유사한 상황들에 대한 주의를 환기시킵니다.

장치에 표시된 기호들

다음 표는 장치에서 볼 수 있는 기호들을 설명합니다.

표 5: 장치에 표시된 기호들의 정의

 켜 (전원) IEC 417, No. 5007	 끄 (전원) IEC 417, No. 5008	 접지(지면) IEC 417, No. 5017	 보호 접지(지면) IEC 417, No. 5019
 프레임 또는 새시 IEC 417, No. 5020	 등전위성 IEC 417, No. 5021	 직류 IEC 417, No. 5031	 교류 IEC 417, No. 5032
 직류와 교류 모두 IEC 417, No. 5033-a	 클래스 II 장비 IEC 417, No. 5172-a	 3상 교류 IEC 617-2, No. 020206	
 주의 (동봉 문서 참조) ISO 3864, No. B.3.1	 주의, 감전 위험 ISO 3864, No. B.3.6	 주의, 표면이 뜨거움 IEC 417, No. 5041	

안전 절차 및 예방조치

본 기계의 모든 작동 시에 다음의 일반 안전 예방조치를 준수하십시오. 아래 예방조치를 준수하지 않거나 본 매뉴얼의 다른 부분에 있는 특정 경고를 준수하지 않을 경우, 기계 사용 목적의 안전 기준을 위반하는 것이 되며, 장비가 제공하는 보호기능을 손상시킬 수 있습니다. MKS Instruments, Inc.는 고객이 본 요건을 준수하지 않는 경우에 대해서는 어떠한 책임도 지지 않습니다.

부품을 교체하거나 기계를 개조하지 마십시오

교체 부품을 설치하거나 기계에 허가되지 않은 어떠한 수정도 가하지 마십시오. 서비스와 수리가 필요한 경우에는 모든 안전 특성이 유지되도록 기계를 MKS 보정 서비스 센터(MKS Calibration and Service Center)로 보내주십시오.

자력이 있는 사람에게만 서비스를 받으십시오

작동하는 사람은 기계 걸면을 제거해서는 안됩니다. 부품 교체 및 내부 조정은 자력이 있는 서비스 기사에게만 받으실 수 있습니다.

전류가 통하는 회로에서 분리해 보관하십시오

전원 케이블을 연결한 채로 부품을 교체하지 마십시오. 일부 환경에서는 전원 케이블을 제거한 상태라도 위험 전압이 존재할 수 있습니다. 부상을 방지하려면, 전원을 항상 분리하고 회로를 만지기 전에 회로를 방전시키십시오.

청소 시에는 적절한 절차를 사용하십시오

본 기계는 환기 후드 아래에서 청소되어야 하며, 인체 보호를 위해 장갑을 착용해야 합니다.

폭발성 환경에서 작동하지 마십시오

폭발을 방지하려면, 폭발성 환경에서 작동하도록 특별히 승인받지 않은 경우 본 제품을 폭발성 환경에서 작동하지 마십시오.

적절한 조립부품과 조임 절차를 사용하십시오

모든 기계 조립부품은 제품 사양과 일치해야 하고, 기계의 사용 목적에 부합해야 합니다. 제조업체의 지시에 따라 조립부품을 조립하고 조이십시오.

누출방지 조립부품을 점검하십시오

기계 설치를 진행하기 전에 기계의 모든 연관 연결부를 점검해 누출방지 설치가 되었는지 확인하십시오.

안전한 흡입 압력에서 작동하십시오

이 장치는 절대 정격 최대 압력보다 높은 압력에서 작동해서는 안됩니다(최대 허용 압력에 대해서는 제품 사양을 참조하십시오).

장치를 오염이 없는 곳에 보관하십시오

장치를 사용하기 전이나 사용 중에는 어떠한 종류의 오염 물질도 허용해서는 안됩니다. 먼지, 때, 보풀, 유리 조각, 금속 조각과 같은 오염 물질은 영구적으로 장치를 손상시킬 수 있습니다.

온도 제어 장치의 경우 알맞은 시동 시간을 두십시오

온도 제어 장치는 장치가 설계 작동 온도와 일치하고 이 온도에서 안정화될 수 있도록 충분한 시간을 허용해야만 사양에 맞게 작동합니다. 시동이 완료될 때까지 장치를 영점 설정하거나 보정하지 마십시오.

Chapter One: General Information

Introduction

The MC20A Mass Flow Controller (MFC) is a high flow, metal sealed subset of the ALTA™ series of digital mass flow devices. As such, device operation is the same and features are similar. DeviceNet MFCs are covered under a separate manual (P/N 136365-P1) and supplement.

Based on a patented MKS Instruments measurement technique, these instruments are laminar flow controllers whose precise indication of mass flow is achieved through the use of a bypass element in parallel with the sensor tube. The controller includes a metal cover and RF bypass capacitors and incorporates a design that virtually eliminates RFI and EMI interference. The MC20A MFCs carry the CE mark indicating compliance with the EMC Directive 89/336/89.

Use the MC20A MFC when both gas flow control and gas flow measurement are required. It is supplied with a normally closed flow control valve.

The MC20A MFCs are available in a variety of configurations and types to suit your specific application needs. Appendix C, *Model Code Explanation*, page 51, contains the options that must be specified when ordering an MFC. Configuration choices include full scale flow range, fitting type, and electrical communications/connections.

Design Features

The design of the MC20A MFCs incorporates an advanced flow sensor, a control valve, and an optimized bypass. The latest generation two-element sensing circuit provides accurate, repeatable performance across the entire device operating range. A low temperature effect from ambient temperature change is ensured. The optimized sensor/bypass arrangement minimizes the flow splitting error for gases with different properties, which dramatically improves measurement accuracy when gases other than the calibration gas are used.

Digital Features

The digital flow calibration, coupled with a standard 11 point calibration, provides for high flow accuracy over a wide range of setpoints. In addition, the digital control loop provides very fast control response, even to low setpoints. The MC20A MFCs accept up to 20 gas tables. Each gas table has its own PID tuning parameters to allow the transient response for each gas table to be optimized for the gas, full scale flow range, and application. The unit operates like a standard analog flow controller but the gas tables and PID parameters can be accessed digitally through a communication port using special MKS-furnished RS-232 adapter cable and graphical user interface (GUI).

Reliability

To provide excellent reliability, the design contains a low mechanical and electronic components count and has successfully passed the following test:

- STRIFE, including temperature cycling and vibration (sine and random tests)

And with a metal braided, shielded cable, properly grounded at both ends:

- EMC Directive 89/336/EEC for CE Mark compliance

Cleanliness Features

The MC20A MFCs use only metal for all external seals. The metal seals eliminate gas permeation and ensure extremely low external leakage. The MC20A MFC mechanical design incorporates minimal wetted surface area and virtual leaks, assuring rapid dry-down. To further enhance its cleanliness, all internal surfaces are precision machined, electropolished, and subjected to a proprietary cleaning process under Class 100 conditions. The instrument is assembled and packaged in a Class 100 clean room environment.

How This Manual is Organized

This manual is designed to provide instructions on how to set up, install, and operate an MC20A MFC.

Before installing and/or operating your MC20A MFC in a system, carefully read and familiarize yourself with all precautionary notes in the *Mass Flow Controller Safety Information* section at the front of this manual. In addition, observe and obey all WARNING and CAUTION notes provided throughout the manual.

Chapter One: General Information (this chapter) introduces the product and describes the organization of the manual.

Chapter Two: Installation explains the environmental requirements and describes how to mount the instrument in your system.

Chapter Three: Overview gives a brief description of the instrument and its functionality.

Chapter Four: Operation describes how to use the instrument and explains all the functions and features.

Chapter Five: Maintenance lists any maintenance required to keep the instrument in good working condition.

Chapter Six: Troubleshooting provides a reference should the instrument malfunction.

Appendix A: Product Specifications lists the specifications of the instrument.

Appendix B: Gas Correction Factors lists the gas correction factors of commonly used gases.

Appendix C: Model Code Explanation describes the model code.

Appendix D: Mass Flow Controller Sizing Guidelines describes the guidelines for correctly sizing MFCs for your process application and is provided for reference.

Appendix E: MKS MC20A Digital MFC Graphical User Interface describes the Windows[®]-based graphical user interface (GUI). This appendix provides detailed information on the interface kit and user manipulation of gas tables and PID parameters.

Customer Support

Standard maintenance and repair services are available at various regional MKS Calibration and Service Centers. MKS also accepts the instruments of other manufacturers for recalibration using the Primary and Transfer Standard calibration equipment located at our regional service centers.

If any difficulties arise in the use of your MC20A MFC, or to obtain information about companion products MKS offers, contact any authorized MKS Calibration and Service Center. If it is necessary to return the instrument to MKS, please obtain an RMA Number (Return Material Authorization Number) from the MKS Calibration and Service Center before shipping. The RMA Number expedites handling and ensures proper servicing of your instrument.

Please refer to the inside of the back cover of this manual for a list of MKS Calibration and Service Centers.

**Warning**

All returns to MKS Instruments must be certified free of harmful, corrosive, radioactive, or toxic materials.

This page intentionally left blank.

Chapter Two: Installation

How to Unpack the MC20A MFC

MKS has carefully packed your MC20A MFC so that it will reach you in perfect operating order. Upon receiving the unit, however, you should check for defects, cracks, broken connectors, etc., to be certain that damage has not occurred during shipment.



Note Do *not* discard any packing materials until you have completed your inspection and are sure the unit arrived safely.

If you find any damage, notify your carrier and MKS immediately. If it is necessary to return the unit to MKS, obtain an RMA Number (Return Material Authorization Number) from the MKS Calibration and Service Center before shipping. Please refer to the inside of the back cover of this manual for a list of MKS Calibration and Service Centers.

Opening the Package

The MC20A MFC is assembled, leak tested with helium, and calibrated in a clean room environment. The instrument is packaged in this environment to ensure maintenance of its particle free condition during shipment. It is very important to remove the packaging according to good clean room practices. To maintain at least a minimal level of clean room standards, follow the instructions below:

1. Remove all cardboard and packaging materials. Discard before entering the garmenting room.
2. Remove the outer plastic shipping container in an ante room (garmenting room) or transfer box.
Do not allow this container to enter the clean room.
3. Remove the inner bag in the clean room.
4. Inspect for any damage.



Caution **Only qualified individuals should perform the installation and any user adjustments. Individuals must comply with all necessary ESD handling precautions while installing and adjusting the instrument. Proper handling is essential when working with all highly sensitive precision electronic instruments.**

Unpacking Checklist

Standard Equipment:

- MKS MC20A Mass Flow Controller
- MKS MC20A Mass Flow Controller Instruction Manual (this book)

Product Location and Requirements

- Ventilation requirements include sufficient air circulation
- Ambient operating temperature range: 15° to 40° C (59° and 104° F)
- Power requirements: $\pm 15 \pm 5\%$ VDC, 300 mA maximum current
or 24 VDC power option, 400 mA maximum current
- Storage temperature range: -20° to 80° C (-4° and 176° F)
- Typically, mount the MC20A MFC in a horizontal, base down (HBD) orientation (SEMI E80-U299 Attitude #1). Prior to installation, check the outlet end of the enclosure for labels indicating alternative orientations. If no label is present, the device is configured for the standard HBD installation.

If you intend to install the device in an orientation other than that indicated, contact the MKS Service Department for assistance in reconfiguring.

- Install a separate positive shutoff valve if your system cannot tolerate any leakage through the MC20A MFC. The internal flow control valve is not a positive shutoff valve so some leakage across the valve may occur.



Warning Your corporate policy on handling toxic or hazardous gases supersedes the instructions in this manual. Comply with your corporate policy. MKS assumes no liability for the safe handling of such materials.

- Install the MC20A MFC in a “flowing” system where gas is continually added and evacuated. Do *not* use the controller in a “dead-ended” system (a system which cannot remove excess mass). The MC20A MFC can not vent excess mass to the atmosphere.
- Warm up time: 30 minutes
- Use high purity gas filters in line upstream of the controller.
- Observe the pressure limits for the flow controller.
 - Maximum gas inlet pressure is 150 psig with properly configured valve (consult factory for cases where inlet pressure is expected to exceed 50 psig).
 - Operational differential pressure is 20 to 50 psig. In some cases, depending on gas type and outlet pressure conditions, a differential pressure somewhat greater than 20 psi is required.
 - The standard valve configuration provides control over this pressure range with the outlet at atmospheric pressure.

For additional information, refer to Appendix A, *Product Specifications*, page 45.



Caution The standard MC20A product is intended for installation in horizontal, base down (HBD) orientation (SEMI E80-U299 Attitude #1).

Check the orientation label on the outlet end of the device (on the enclosure). If you intend to install in alternative orientations, contact the MKS Service Department for assistance in reconfiguring. Refer to Appendix C, page 51, for details.

Setup

This section describes how to install the MC20A MFC into your system.

Follow the guidelines below when setting up the MC20A MFC.

1. Set the controller into position where it will be connected to a gas supply. Installation of the MC20A in any orientation other than that for which it was configured, may cause a calibration shift. The MC20A MFC default orientation is horizontal, base down (HBD), SEMI E80-U299 Attitude #1. Prior to installation, check the outlet end of the enclosure for labels indicating alternative orientations. If no label is present, the device is configured for the standard HBD installation. If you intend to install the device in an orientation other than that indicated, contact the MKS Service Department for assistance in reconfiguring.
2. Allow adequate clearance for the cable connector.
Straight shielded connectors require approximately 3" (76 mm) of height. Right angle connectors require approximately 2" (51 mm) of height.
3. Install the flow controller in the gas stream such that the flow will be in the direction of the arrow on the front of the controller.
 - A. Orient the unit properly.
 - B. Mount the unit into place with the proper hardware. Take care that the gas flow is in the direction of the arrow on the enclosure of the unit. For surface mount versions, the gas connection is made at this time. Be sure to insert the appropriate C-seal or W-seal.
 - C. Connect the gas supply (if not a surface mount unit). For VCR connections, remember to include the gasket.
 - D. Perform external leak test.
 - E. Plug in connector from power/signal cable.
 - F. Power the unit and allow 30 minute warm-up.

Refer below for outline dimensions of the flow controllers and locations for the mounting hardware.

Front and Back Views

The front of the MC20A MFC has an arrow to indicate the direction of gas flow through the unit. The back of the MC20A MFC contains the serial label and connector pin-outs.

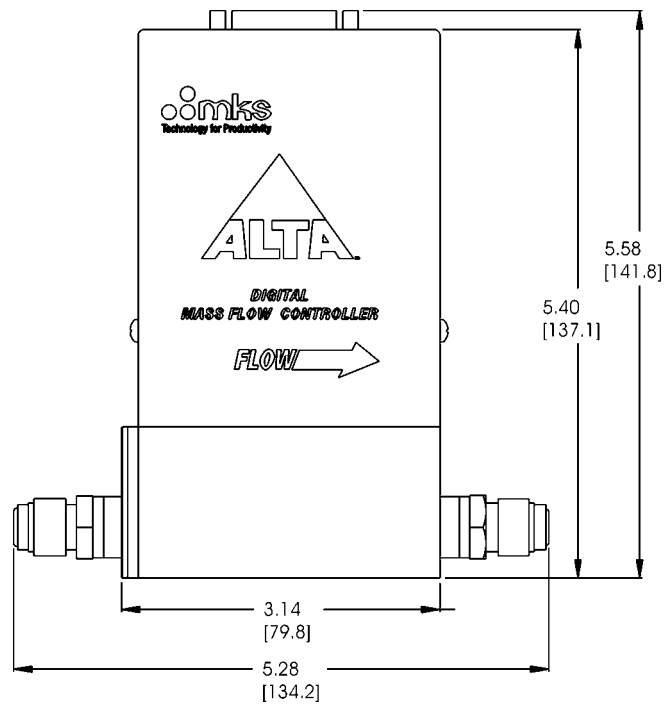

Figure 1: Front View of the MC20A MFC with 4 VCR Fittings

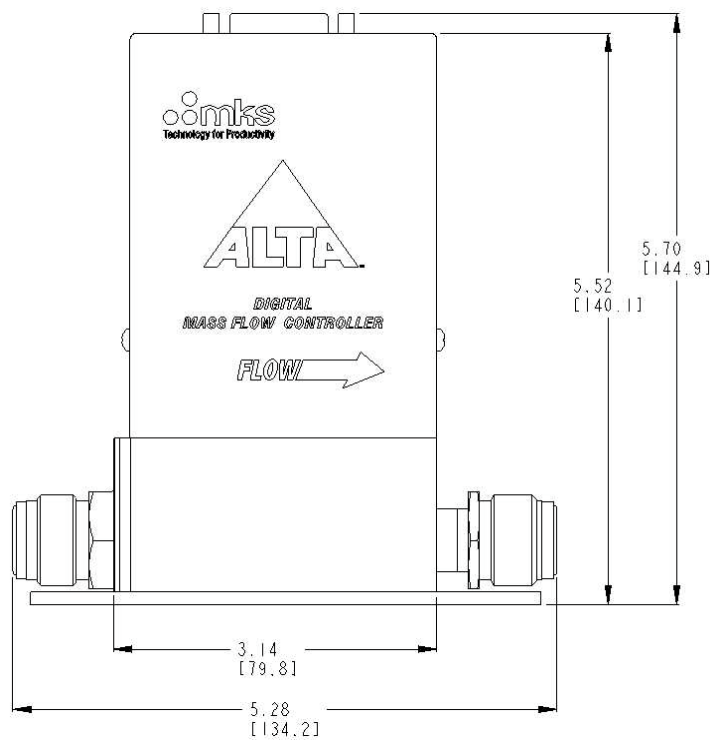

Figure 2: Front View of the MC20A MFC with 8 VCR Fittings (includes required mounting plate)

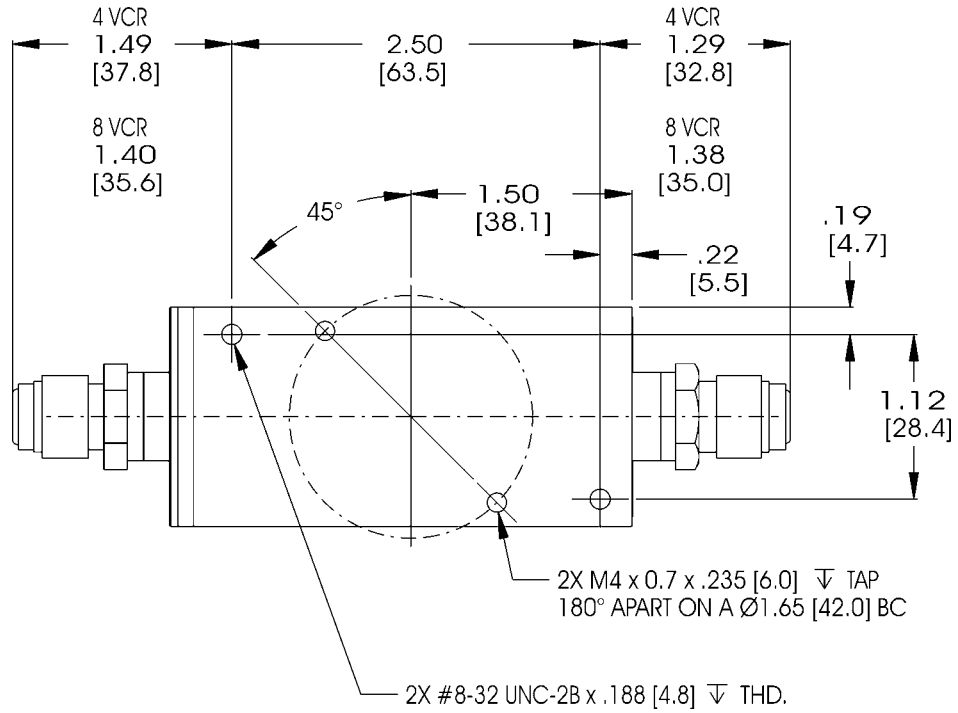
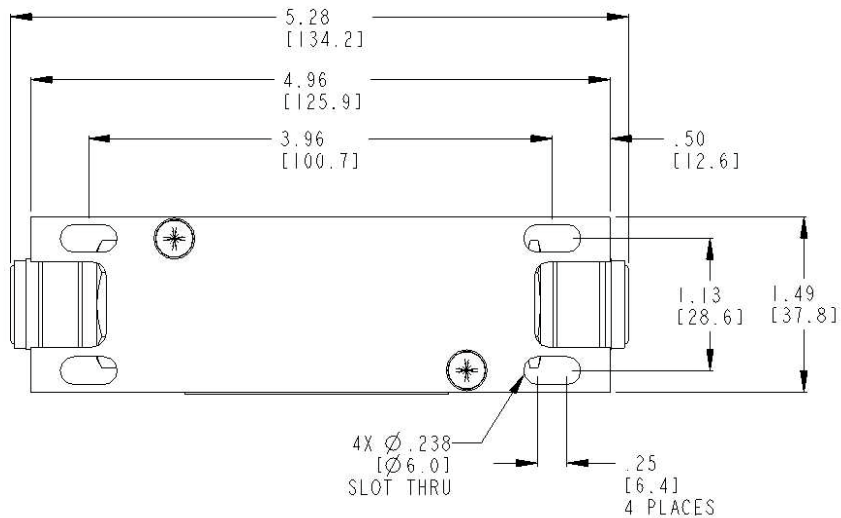

Figure 3: Bottom View of the MC20A MFC with 4 VCR Fittings



BOTTOM VIEW WITH 8 VCR FITTINGS
(INCLUDES .12 [3.0] THK. MOUNTING PLATE AND (2) SCREWS)

**Figure 4: Bottom View of the MC20A MFC with 8 VCR Fittings
(includes required mounting plate)**

Inlet End View

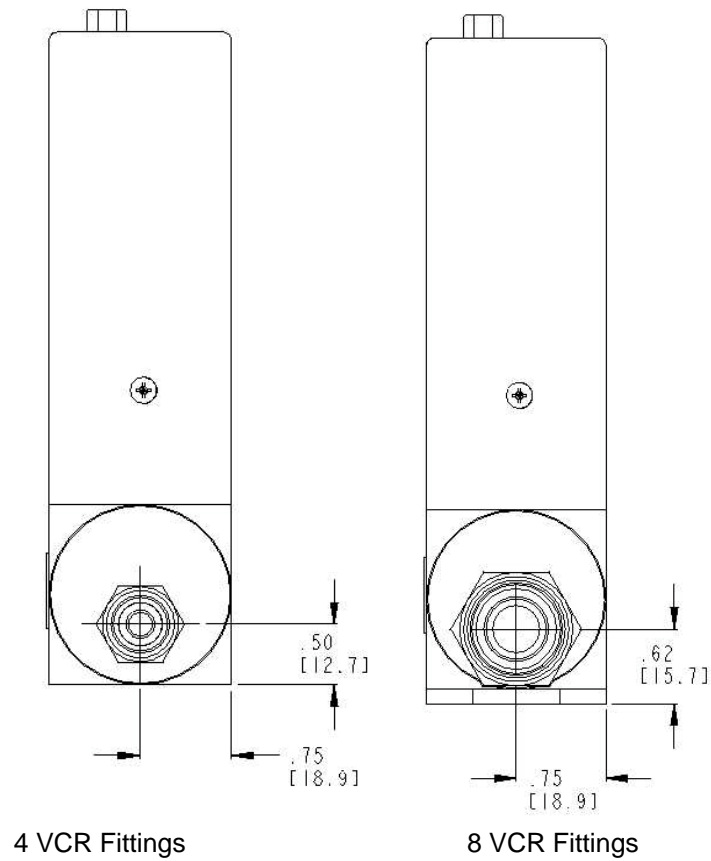

Figure 5: Inlet End View of the MC20A MFC

Top View

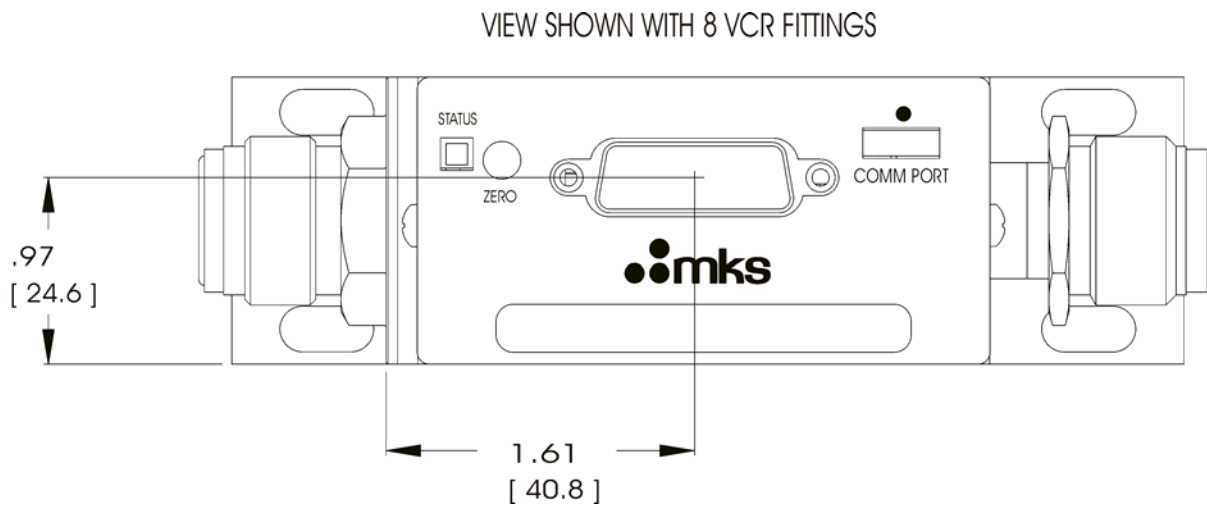

Figure 6: Top View of the MC20A MFC with 15-Pin Analog Interface

Labels

Each MC20A unit has two serial number labels, a small one on top side and the standard, larger label on the back side. Each label shows the serial number, the model code, the full scale flow range, and the calibration gas.



Figure 7: Serial Number Label

Fittings

MC20A MFCs are available with the following fittings:

- Swagelok VCR-4, Male (50 SLM models only)
- Swagelok VCR-8, Male (all flow ranges)

Mounting Hardware for VCR-4 Fittings

MC20A MFCs with VCR-4 male fittings have four threaded mounting holes located on the bottom or base of the unit: two #8-32 and two M4. Depending on the hole pattern chosen, use #8-32 UNC-2B or M4 hardware to mount the instrument. Figures 3 and 4, page 21, show the location and dimensions of the mounting holes for standard axial fittings.

Mounting Hardware for VCR-8 Fittings

MC20A MFCs with VCR-8 male fittings are supplied with an integral mounting plate installed. This plate includes four slotted holes that accept #12 screws.

Gas Flow

The proportional control valve is *not* a positive shutoff valve. Some leakage across the valve may occur. Refer to Appendix A, *Product Specifications*, page 45, for the leak integrity specifications. If necessary, install a separate positive shutoff valve in your system.



Note Connect the MC20A MFC to your system so that the gas flows in the direction of the flow arrow on the front of the unit.

Electrical Connections

If you are using the MC20A instrument with any equipment other than corresponding MKS power supply/readout units, consult the manufacturer’s specifications for connection, and for proper electrical and power characteristics. Refer to *Product Location and Requirements*, page 18, for electrical requirements of the MC20A MFC.

MC20A MFCs are available with the different analog interface configurations: 15-pin “D” with standard MKS pinout assignments and a 15-pin “D” with alternative pin assignments.

15-Pin Type “D” Connector – Standard MKS Pinout Assignments

The table below lists the pinout of the 15-pin Type “D” connector for the MC20A MFC.

**Table 6: 15-Pin Type “D” MFC
Connector Pinout – Standard Assignments (Model Code B)**

Pin	Assignment	24 VDC Power Option*
1	Valve Test Point	
2	Flow Signal Output (0 to +5 VDC)	
3	Valve Close (TTL low)	
4	Valve Open (TTL low)	
5	Power Supply Common	Digital Ground (see Note 4 below)
6	-15 VDC \pm 5%	Power Return (see Note 4 below)
7	+15 VDC \pm 5%	+24 V (see Note 4 below)
8	Setpoint Input (0 to +5 VDC)	
9	Zero Function	
10	Optional Input (0 to +5 VDC)	
11	Signal Common	
12	Signal Common	
13	No Connection	
14	No Connection	
15	Chassis Ground	
* To operate on 24 VDC power, the device must be ordered with the 24 VDC power option installed.		



Note

1. The “No Connection” pin assignment refers to a pin with no internal connection.
2. The 0 to 5 VDC flow signal output comes from pin 2 and is referenced to pin 12 (signal common).
3. Any appropriate 0 to 5 VDC input signal of less than 5K ohm source impedance referenced to pin 11 can be used to supply a setpoint signal to pin 8.
4. To operate the 24 VDC power option, the Power Return and Digital Grounds should be externally connected either in the cable or the power supply.

15-Pin Type “D” Connector – Alternative Pinout Assignments

The table below lists the pinouts of the alternative 15-pin Type “D” connector for the MC20A MFC.

**Table 7: 15-Pin Type “D” MFC
Connector Pinout – Alternative Assignments (Model Code E)**

Pin	Assignment	24 VDC Power Option*
1	Signal Ground 1	
2	Flow Signal Output (0 to +5 VDC)	
3	Not Used	
4	Not Used	
5	+15 VDC \pm 5%	+24 V (see Note 4 below)
6	-15 VDC \pm 5%	Power Return (see Note 4 below)
7	Valve Test Point	
8	Setpoint Input (0 to +5 VDC)	
9	Power Common	Digital Ground (see Note 4 below)
10	Signal Ground 2	
11	+5 VDC Reference	
12	Valve Override Valve Open: +5 to + 15 VDC Valve Close: -5 to -15 VDC	
13	Not Used	
14	Chassis Ground	
15	External Sensor Input	
* To operate on 24 VDC power, the device must be ordered with the 24 VDC power option installed.		



Note

1. The “Not Used” pin assignment refers to a pin with no internal connection.
2. The 0 to 5 VDC flow signal output comes from pin 2 and is referenced to pin 1 (signal ground 1).
3. Any appropriate 0 to 5 VDC input signal of less than 5K ohm source impedance referenced to pin 10 can be used to supply a setpoint signal to pin 8.
4. To operate the 24 VDC power option, the Power Return and Digital Grounds should be externally connected either in the cable or the power supply.

Interface Cables

As of January 1, 1996, all products shipped to the European Community must comply with the EMC Directive 89/336/EEC, which covers radio frequency emissions and immunity tests. MKS products that meet these requirements are identified by application of the CE Mark.

This MKS product meets CE Mark requirements, per EMC Directive 89/336/EEC. To ensure compliance when installed, an overall metal braided shielded cable, properly grounded at both ends, is required during use. MKS offers a variety of interface cables, listed in Table 8.



Note

1. An overall metal braided, shielded cable, properly grounded at both ends, is required to meet CE Mark specifications.
2. To order an overall metal, braided, shielded cable, add an “S” after the cable type designation. For example, to order a standard connection cable to connect the MFC to a power supply with a 15-pin Type “D” connector, use part number CB259-5; for an overall metal braided, shielded cable use part number CB259S-5.

Table 8: MKS Interface Cables

MFC End	Power Supply End	
	15-Pin Type “D”	Flying Leads
15-pin Type “D”	CB147-1 CB259-5 CB1480-1*	CB259-6
* Required for use with MKS Model 246 and 247 power supply units.		

Generic Shielded Cable Description

MKS offers a full line of cables for all MKS equipment. Should you choose to manufacture your own cables, follow the guidelines listed below:

1. The cable must have an overall metal *braided* shield, covering all wires. Neither aluminum foil nor spiral shielding will be as effective; using either may nullify regulatory compliance.
2. The connectors must have a metal case with direct contact to the cable shield on the whole circumference of the cable. The inductance of a flying lead or wire from the shield to the connector will seriously degrade the shield’s effectiveness. Ground the shield to the connector before its internal wires exit.
3. With very few exceptions, the connector(s) must make good contact to the controller’s case (ground). “Good contact” is about 0.01 ohms and the ground should surround all wires. Contact to ground at just one point may not suffice.
4. For shielded cables with flying leads at one or both ends; it is important to ground the shield at each such end *before* the wires exit. Make this ground with absolute minimum length. (A ¼ inch piece of #22 wire may be undesirably long since it has approximately 5 nH of inductance, equivalent to 31 ohms at 1000 MHz). After picking up the braid ground, keep wires and braid flat against the case. With very few exceptions, grounded metal covers are not required over terminal strips. If one is required, it will be stated in the Declaration of Conformity.

5. In selecting the appropriate type and wire size for cables, consider:
 - A. Voltage ratings.
 - B. Cumulative I^2R heating of all the conductors (keep them safely cool).
 - C. IR drop of the conductors, so that adequate power or signal voltage gets to the controller.
 - D. Capacitance and inductance of cables that handle fast signals (such as data lines or stepper motor drive cables).
 - E. Some cables may need internal shielding from specific wires to others.

This page intentionally left blank.

Chapter Three: Overview

General Information

Typical Control System Configuration

The MC20A MFC is used in a wide variety of control systems, most of which share several characteristics. Typically, a control system consists of four basic parts:

- Mass flow transducer
- Metering and control electronics
- Control valve
- Flow system (whose flow is being controlled by the MC20A MFC)

The MC20A MFC provides the first three components. The mass flow transducer is an MKS design. The MC20A MFC instrument contains the electronics necessary for flow control. The control valve included in the MC20A MFC is a proportional control valve. The flow system can be any process whose flow you need to control. In addition, the MC20A MFC is capable of metering the mass flow of the gas during the flow control operation.

Flow Measurement Overview

The MC20A MFC measures the mass flow rate of a gas and controls the flow rate according to a given setpoint. The control range is from 2% to 100% of Full Scale (F.S.) with an accuracy of $\pm 1\%$ of Reading (25% to 100% of Full Scale). For setpoints between 10% and 25%, MC20A MFCs have an accuracy of $\pm 0.25\%$ FS.

Flow Path

Upon entering the MC20A MFC, the gas stream passes first through the metering section of the instrument for its mass flow to be measured. The gas moves on through the control valve, which regulates the flow rate according to the given setpoint, and then exits the instrument at the established rate of flow.

The metering section consists of a sensor tube and parallel bypass.

The geometry of the sensor tube, in conjunction with the specified full scale flow rate, ensures fully developed laminar flow in the sensing region. The bypass elements are specifically matched to the characteristics of the sensor tube to achieve a laminar flow splitting ratio which remains nearly constant throughout each range.

Flow Control Range

The MC20A MFC can control flow over a range of 2 to 100% of full scale flow. This means that a 50 SLM MC20A MFC can control flow from 1 SLM to 50 SLM, whereas a 200 SLM instrument can control flow from 4 SLM to 200 SLM.

Measurement Technique

The flow measurement is based on differential heat transfer between temperature sensing heater elements which are attached symmetrically to the sensor tube. This senses the thermal mass movement which is converted to mass flow via the specific heat, C_p , of the gas.

Control Circuitry

The controller employs the above measurement technique and utilizes a control circuit that provides drive current for the proportioning control valve. The flow controller accepts a setpoint signal, compares it to its own flow signal, and generates an error voltage. This error signal is then conditioned by a PID (Proportional-Integral-Derivative) algorithm and amplified so that it can reposition the control valve, thus reducing the control error to zero.

Since the control valve is normally closed, the MC20A MFC instrument lifts the armature and plug assembly from the seat to regulate the gas flow rate.

Control Valve

The control valve is a specially constructed solenoid valve in which the armature (moving valve mechanism) is suspended. The arrangement ensures that no friction is present and makes precise control possible. The MC20A MFC has a normally-closed valve. The control current is used to lift the armature and plug assembly from the seat, allowing a controlled flow of gas.

How the MC20A MFC Works

The MC20A MFC compares the flow reading to the setpoint, and positions the valve to maintain, or achieve, the setpoint rate. The controller functions as a PID (Proportional-Integral-Derivative) controller. The Proportional (P), Integral (I) and the Derivative (D) terms can be adjusted digitally through the communication port on top of the MC20A MFC. MKS can supply an adapter cable between this port and the standard 9-pin RS-232 connection on a personal computer. In addition, MKS offers a graphical user interface (GUI) which allows easy communication with the controller.

Example

Assume that your MC20A MFC is positioned upstream of the process chamber. The MC20A MFC is positioned *before* the chamber so it will regulate the flow rate of the gas entering the process chamber.

When the actual flow rate reading is *less than* the setpoint value, the MC20A MFC opens the valve to increase the amount of gas entering the system. As the valve opens, assuming adequate differential pressure across the flow controller, gas enters the process chamber, so the flow rate rises to meet the setpoint value.

When the actual flow rate reading is *more than* the setpoint value, the MC20A MFC closes the valve to decrease the amount of gas entering the system. As the valve closes, there is a reduced flow of gas entering the process chamber, so the flow rate decreases to meet the setpoint value.



Note

The MC20A MFC must have sufficient pressure on its inlet side to achieve the setpoint.

Overview of Digital Operation

Your MC20A MFC has a digital heart but operates like a standard analog flow controller through 15-pin sub-miniature D connectors. It is powered with ± 15 Volts (+24 VDC is optional), accepts 0-5 VDC setpoints, and outputs 0-5 VDC flow signals. The digital logic allows the following:

Gas Tables

Each MC20A MFC supports 20 gas calibration tables. The user may copy factory calibrations into new tables to accommodate alternative gases or adjust the full scale flow rate. It is also possible, if certified flow

standards are available, to create entirely new calibration tables with up to 21 points. The standard factory calibration contains 11 points.

Tables 0-5 are reserved for MKS factory use only. They may be copied but not erased or edited.

Tables 6-19 may be user created.

The nameplate gas, as the controller is delivered from the factory, is placed in Table 1. Table 0 is reserved for the base factory calibration. Tables 2-5 are reserved for additional factory tables, including tables for process gases (based on the base calibration) and also calibrations performed with alternative gases.

Associated with each table are the PID control parameters. This allows each gas table to have its own optimized PID settings. Activating a particular table automatically activates the associated PID settings. Thus, different process gases can be chosen and the optimum PID parameters can be selected.

The digital communications are achieved through the “Comm. Port” on the top of the controller using an RS-232 adapter cable that MKS supplies and associated graphical user interface (GUI). These items are offered in complete hardware/software interface kits, P/Ns 133730-G1 (with USB port security key) and 133730-G2 (with parallel port security key). For more detailed information on user manipulation of gas tables and PID parameters, refer to the instructions for the GUI use in Appendix E, page 55.

PID Parameters

Each gas table has its own optimized PID settings. Activating a particular table automatically activates the associated PID settings. In addition to creating gas tables for various gases, it is possible to create multiple gas tables for the same gas but with different PID parameters to suit different pressure conditions.

Each gas table actually includes two sets of PID parameter, one for standard flow control and the other for optional input control.

Graphical User Interface

The digital communications are achieved through the “Comm. Port” on the top of the controller using an MKS-supplied communications kit that includes an RS-232 cable, a proprietary adapter cable, and a Windows-based graphical user interface (GUI). The GUI is provided with a security hard-key, to fit either USB or parallel ports. For more detailed information on the interface kit and user manipulation of gas tables and PID parameters, refer to the GUI instructions in Appendix E, page 55.



Warning

The digital interface is designed for short term communication to the controller during set-up and troubleshooting. Do not use for ongoing communication during normal operation.

Tuning the MC20A MFC

Tuning optimizes the MC20A MFC’s control of flow rate. The Proportional (P), Integral (I), and Derivative (D) terms adjust the response of the MC20A MFC to changes in either mass flow rate setpoint or system pressure.

Your MC20A MFC is tuned at the MKS factory for excellent flow response and stability under typical operating conditions. However, your process conditions may be different, prompting you to adjust the PID values for optimum performance.



Caution

Communication through the serial port is intended for device set-up only. Do not use when the process tool is in operation!

Accessing PID Tuning Parameters

The PID tuning parameters are associated with specific gas tables. This allows each gas to have its own optimized PID values.

The MKS supplied RS-232 adapter cable and graphic user interface (GUI) allows access to the controller gas tables and associated PID tuning parameters. To access a particular set of PID parameters, the associated gas table must be “active”. For more detailed information, please refer to Appendix E, page 55.

Error Signal

An error signal is the difference between the measured mass flow rate and the setpoint mass flow rate. The error signal is the basis for the operation of the PID algorithm.

Proportional Term

When the Proportional (P) term, or gain, is multiplied by the error signal, a proportional valve drive signal results. The higher the Proportional (P) control, the greater the change in valve drive signal for a given error signal. Typically, a higher Proportional (P) control setting yields a faster response. However, too high a Proportional (P) control setting will cause the mass flow rate to oscillate around the setpoint. Too low a Proportional (P) control setting will result in a slow response from the MFC. Figures 8 and 9 show the effects of the Proportional (P) term.

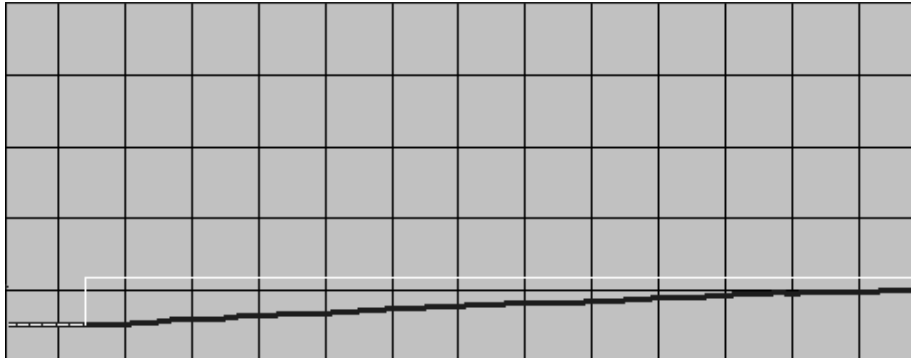

Figure 8: Effects of the Proportional Term (Low Proportional Term)

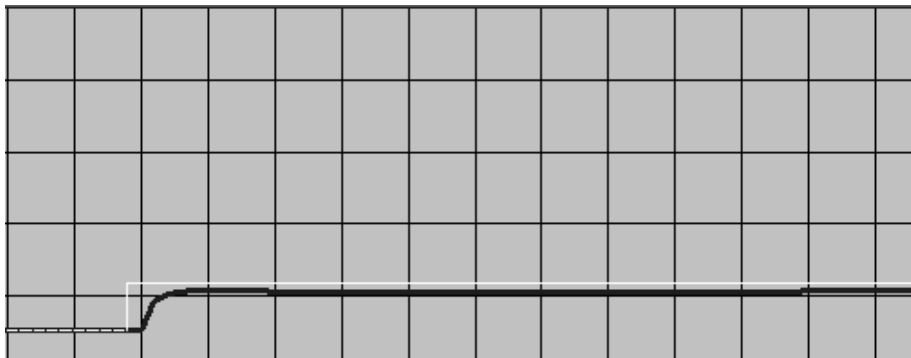

Figure 9: Effects of the Proportional Term (High Proportional Term)

Adjusting the Proportional Control

The Proportional (P) term is adjusted through the “Comm Port” using an MKS supplied RS-232 adapter cable and graphical user interface (GUI). See the instruction manual accompanying the GUI.

Integral Term

The action of the Integral (I) term creates a valve drive signal that is proportional to the magnitude and sign of the area under the error signal curve (error signal with respect to time). Therefore, as time passes, the integral term acts to position the valve to reduce the error signal to zero. An increase in the integration time increases the period of time over which the error signal is generated, and the system response gets slower. Figures 10 and 11 show the effect of the Integral term.

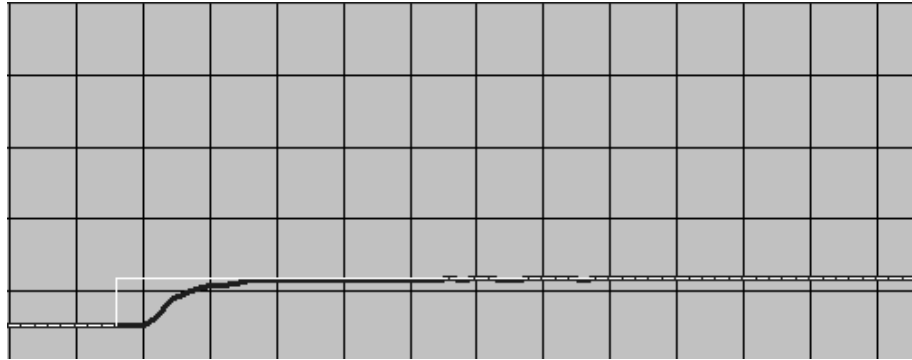

Figure 10: Effects of the Integral Term (Low Integral Term)

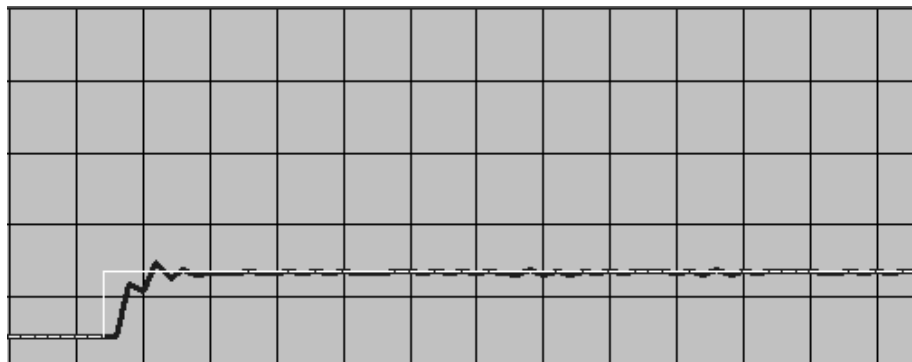

Figure 11: Effects of the Integral Term (High Integral Term)

Adjusting the Integral Control

The Integral (I) term is adjusted through the “Comm Port” using an MKS supplied RS-232 adapter cable and graphical user interface (GUI). See the instruction manual accompanying the GUI.



Note To shorten the integration time, increase the I term setting.

Derivative Term

The action of the Derivative (D) term creates a valve drive signal that is proportional to the rate of change of the error signal over time. In moderate amounts, it can be used to reduce overshoot within the system by adding predictive capabilities to the control algorithm. At high rates of change of the error signal as it approaches the setpoint quickly (negative slope of the absolute error over time), the derivative term reduces the effects of the Proportional term. Excessively high Derivative term values can result in instability of the controller.

In general, MC20A MFCs control well with the Derivative term equal to zero.

Adjusting the Derivative Control

The Derivative (D) term is adjusted through the “Comm Port” using an MKS supplied RS-232 adapter cable and graphical user interface (GUI) . See the instruction manual accompanying the GUI.

Optimizing PID Control Settings

Optimizing the MC20A MFC response *in your system* involves adjusting the Proportional, Integral, and Derivative (PID) terms. Since every system is different, the optimum PID settings may vary. Operating pressures, process gas density, and target setpoints, all contribute to determining the ideal settings.

Guidelines for Flow Control Tuning

- Tuning is best done with setpoint changes from zero to the target flow rate.
- Units are usually delivered with P values between 2600 and 7000, I values between 140 and 350, and the D term set at zero. The P term is generally around 20 times the value of the I term. After optimizing for your process, the PID values generally will remain within this range.
- Increasing the I term will reduce response time, especially at setpoints below 20% of full scale, but promote flow overshoot during setpoint changes. Increasing the P term reduces the overshoot because the controller is able to respond more quickly to the indicated overshoot. However, an excessive P term will cause controller oscillation, a highly undesirable condition. Thus, caution must be exercised in setting the P term aggressively.
- Any adjustments to the P and I terms (D is generally kept at zero) should be done incrementally. For improved response, I should be *increased* in increments of 20 and P in increments of 400 between response tests. If excessive overshoot is observed, the P value may be increased somewhat but should not be allowed to exceed 10,000. For improved control stability, the I term should be *decreased* in similar increments (20 for the I term and 400 for the P term).

Guidelines for Pressure Control Tuning (via the Optional Input)

When tuning for pressure control, the behavior described in the flow control tuning section above holds. However, the range of possible control conditions is much greater and the range of possible PID values is correspondingly greater. For example, in controlling downstream pressure around 150 Torr with load switching, I terms of up to 2000 and P values up to 40,000 are not uncommon. The size of initial adjustment increments thus may be much greater than for flow control adjustment.

Chapter Four: Operation

How to Start the MC20A MFC

1. Leak test the fittings on the unit using standard helium leak check procedures.

Do not proceed to the next step until you are certain that there is no gas leakage.

2. Plug the power supply/readout cable (MKS or customer-supplied) into the connector (15-pin “D” type) located at the top of the controller.

Plug the other end of the cable into an MKS or MKS-compatible power supply/readout unit.

3. Apply power to the controller.

When power is first applied, the output signal jumps to over + 7.5VDC. Also, the status LED will alternately switch between red and green color until settling at green. This cycle lasts under 30 seconds.

You can monitor the flow output signal as the heaters stabilize and the output approaches zero.

Approximately 2 minutes after power up, the output signal should be within 10mV (0.2% F.S.) of the final, stabilized voltage. For best accuracy performance, you should allow a full 30 minute warm-up.

Once the controller is sufficiently warmed-up, you can proceed to zero it. See instructions in Section 5.

Power Requirements

The MC20A MFC requires an input voltage of $\pm 15 \pm 5\%$ VDC with 300 mA. With the 24 VDC power option installed, the MC20A MFC requires 24 VDC to power return with 400 mA.

Warm-Up Time

After installation and power up, allow the MC20A MFC to warm up for a minimum of 30 minutes.

How to Zero the Flow Controller

Although MKS flow controllers are zeroed at the factory prior to shipment, it is normal to check the zero and re-zero them, if needed, when they are first installed on the tool.

An MFC will provide a zero output signal under “no flow” gas conditions. Zero offset from improper zeroing procedures can contribute to flow measurement inaccuracy. This is more apparent at the lower end of the controller range.

In order to complete a true zeroing of the controller, ensure the following conditions are satisfied prior to beginning the procedure.

- Controller is installed in the orientation intended for final use (i.e. horizontal base down, vertical flow up, etc.).
- Controller is powered at operating temperature, preferably for 30 or more minutes.
- Controllers subject to ambient temperatures other than room temperature (23° C) should be zeroed under those conditions.
- Pressure drop and flow across the controller is reduced to zero. Depending on the gas panel configuration, this may be done by one of the following procedures.

For Systems With Upstream and Downstream Positive Shut-Off Valves

1. Close both the upstream and downstream shut-off valves.
2. Set the controller to 100% setpoint.
3. Allow pressure across the controller to equilibrate as flow output approaches zero and stabilizes.
4. To ensure that actual flow remains at zero, keep the shut-off valves closed. To the controllers, provide zero setpoint.
5. Wait one minute and activate the zero function. The zero function may be activated in three different ways:
 - Pressing the Zero button on top of the unit.
 - Communicating digitally through the software GUI (clicking the Remote Zero button on the main screen).
 - “B” connector option only: Remotely grounding pin 9 to pins 11 or 12.

For Systems With Downstream Valve Only

1. Zero the controller at typical operating inlet pressure.
2. Close the downstream shut-off valve.
3. Set the controller to 100% setpoint.
4. Allow pressure to equilibrate across the controller as flow output approaches zero and stabilizes.
5. Provide zero setpoint to the controller.
6. Wait one minute and activate the zero function. The zero function may be activated in three different ways:
 - Pressing the Zero button on top of the unit.
 - Communicating digitally through the software GUI (clicking the Remote Zero button on the main screen).
 - “B” connector option only: Remotely grounding pin 9 to pins 11 or 12.

For Systems With Upstream Valve Only

1. The controller may be re-zeroed with the downstream line under vacuum or atmosphere.
2. Close the upstream valve.
3. Set the controller to 100% setpoint.
4. The controller may be evacuated to vacuum or exposed to atmosphere on the downstream side.
5. For either case, the downstream pressure must be kept constant to ensure there are no fluctuations in pressure drop across the controller, which could induce false flow readings.
6. Allow pressure to equilibrate across the MFC as flow output approaches zero and stabilizes.
7. Provide zero setpoint to the controller.
8. Wait one minute and activate the zero function. The zero function may be activated in three different ways:
 - Pressing the Zero button on top of the unit.

- Communicating digitally through the software GUI (clicking the Remote Zero button on the main screen).
- “B” connector option only: Remotely grounding pin 9 to pins 11 or 12.

How to Override the Valve

The valve override feature enables the control valve to be fully opened (purged) or closed independent of the setpoint command signal.

If the MC20A flow controller is equipped with a 15-pin Type “D” connector having standard MKS pinout assignments:

Open the valve by applying a TTL low to pin 4 *or* connect pin 4 to signal ground (pins 11 or 12) or power ground.

Override a setpoint to the controller and *close* the valve by applying a TTL low to pin 3 *or* connect pin 3 to signal ground (pins 11 or 12) or power ground.

If the MC20A flow controller is equipped with a 15-pin Type “D” connector having the alternative pinout assignments:

Open the valve by applying between +5 and +15 Volts to pin 12 (input impedance is 58.5 K-Ohms).

Override a setpoint to the controller and *close* the valve by applying between –5 and –15 Volts to pin 12 (input impedance is 58.5 K-Ohm).



Note To control with a TTL signal, use a tri-stated device.

Priority of the Commands

The MC20A flow controller executes commands based on a hierarchical command structure. The highest priority command is Valve Open, followed by Valve Close, and Setpoint Control. Therefore, if the flow controller is operating under Setpoint Control, you can send a Valve Open command to force the valve to the full open position.



Note When both the Valve Close and Valve Open pins are pulled down, the Valve Open command takes precedence and the valve is moved to the open position.

The Optional Input

The standard 15-pin MC20A MFCs can control flow based on a 0 to 5 Volt signal from an external sensing device using the optional input feature (for a 0 to 10 Volt input range, contact the MKS Applications Department). A common application of this feature is for pressure control using input from a pressure transducer.

To use the optional input feature, route the 0-5 Volt output from the desired external device to the “optional input” pin 10.

Voltage applied to the optional input pin from the external sensing device overrides the signal generated by the internal MC20A flow sensor. The control electronics drives the valve so that the optional input signal matches the setpoint. Use the same pin for the setpoint signal, regardless of whether you are using the optional input or the standard flow control signal.

Although controlling to the external optional input signal, the metered flow output signal is still provided on the standard output pin 2.

PID Tuning

One outstanding feature of the MC20A line of MFCs is that the optional input control has a set of PID parameters which are independent of the PID parameters used for standard flow control. This provides greatly enhanced flexibility in configuring systems which utilize the optional input feature. Refer also to *Optimizing PID Control Settings*, page 34.

Chapter Five: Maintenance

General Information

In general, no maintenance is required other than proper installation and operation. Periodically check for wear on the cables and inspect the enclosure for visible signs of damage. If an MFC fails to operate properly on receipt, check for shipping damage, and check the cable for proper power supply and signal connections. Any damage should be reported to the freight carrier and MKS Instruments immediately. If there is no obvious damage, and the unit fails to operate properly, obtain an RMA Number (Return Material Authorization Number) before returning the unit to MKS Instruments for service to expedite handling and ensure proper servicing of your instrument.

Zero Adjustment

For best accuracy and repeatability, you should check the zero output periodically and reset it, if necessary. The frequency of checking zero depends on the accuracy and repeatability required by your process. Refer to the zero adjustment procedure provided on page 35.

Calibration

It is recommended that the instrument be recalibrated annually if no other time interval has been specifically established. Refer to the inside of the back cover of this instruction manual for a complete list of MKS Calibration and Service Centers.

This page intentionally left blank.

Chapter Six: Troubleshooting

Troubleshooting Chart

Table 9: Troubleshooting Chart

Symptoms	Possible Cause	Remedy
Controller does not power up.	Improper power supply or power cable. Malfunctioning electronics.	Check for proper power to the unit. Return unit for service to MKS Calibration and Service Center.
Controller indicates negative flow.	Incorrect instrument installation (backwards) in process system. Poor zero adjustment.	Reinstall instrument in process system such that gas flow occurs in the direction of the arrow on the front of the instrument. Re-zero the device.
Controller does not track setpoint.	Improper PID settings. Low inlet pressure.	Tune controller according to procedures outlined in instruction manual. Reduce inlet pressure.
Controller mass flow rate oscillates	Incorrect control parameter setting. Incorrect upstream pressure regulator. Upstream pressure too high/low.	Reduce P digitally through COMM PORT. Check manufacturer's specifications for correct upstream pressure regulator. Reduce upstream pressure.
Controller has excessive closed conductance valve leak.	Valve is contaminated. Excessive inlet pressure.	Return unit for service to MKS Calibration and Service Center. Reduce inlet pressure.
Controller does not achieve full flow.	Upstream pressure is too low. Excessive valve pre-load.	Increase upstream pressure. Return unit for service to MKS Calibration and Service Center.

Description of Digital Error Messages

MC20A digital flow controller has some diagnostic capabilities and can output error and warning messages digitally to the GUI. Some of these identify internal controller faults but others identify possible installation issues affecting controller operation. A comprehensive table of messages is provided below:

Table 10: Description of Digital Error Messages

Message Number	Description	Recommended Action
0	Everything O.K.	None needed.
1	Power Ground Faulty	Check system configuration for proper power ground. It should be: ±15 V power; between 0 and –15 V +24 V power; between 0 and +24 V If system meets requirements, return the controller to MKS Service Center.
2	Analog Ground Faulty	Return the unit to the MKS Service Center.
3	Reference Voltage Faulty	Return the unit to the MKS Service Center.
4	Flow Output Voltage Faulty	Return the unit to the MKS Service Center.
5	Pressure Output Channel Faulty	Return the unit to the MKS Service Center.
6	Setpoint Input Channel Faulty	Return the unit to the MKS Service Center.
7	Valve Output Controller Faulty	Return the unit to the MKS Service Center.
8	Flow Sensor Controller Faulty	Return the unit to the MKS Service Center.
9	Not Applicable	
10	Power Supply Voltage Too Low	Check power supply to instrument, both voltage and maximum available current. If power to the instrument is sufficient, return the unit to the MKS Service Center.
11	Internal Temperature Too High	Assure that operating environment surrounding unit is below 40° C limit. This is a warning only. The unit may continue to operate properly although elevated temperature will reduce product life.
12	Power Failure Occurred	Check the power supply to the unit. If power to instrument is sufficient, return the unit to the MKS Service Center.
13	Setpoint Signal Out of Range	Setpoint signal exceeds 110% full scale limit (5.5 Volts).
14	Flow Signal Out of Range	Controller output is beyond 112% full scale limit (5.6 Volts). This is most likely to occur when in metering mode (valve open). This message is a warning only. The unit will continue to function properly. To eliminate this message, reduce flow to the controller.
15	Not Applicable	

(Continued on next page)

Table 10: Description of Digital Error Messages (continued)

Message Number	Description	Recommended Action
16	Wrong Parameter Structure Sent	Indicates an error with the digital interface software.
17	EEPROM Error	Internal data has been corrupted. Perform a “reset” through the GUI. If the error message persists, return the unit to the MKS Service Center.
18	Controller Failure	Message occurs when flow setpoint is not met. Check for adequate inlet pressure. If pressure requirements are met and the message persists, return the unit to the MKS Service Center.

This page intentionally left blank.

Appendix A: Product Specifications

Performance Specifications

Accuracy Mass Flow Controller	1% of reading from 25% to 100% F.S. 0.25% of F.S. < 25% F.S.
CE Compliance Electromagnetic Compatibility ¹	EMC Directive 89/336/EEC
Control Adjustments Derivative Integral Proportional	Adjustable via digital Graphical User Interface
Control Repeatability	±0.2% F.S.
Leak Integrity Internal to external Through closed control valve	<10 ⁻⁹ scc/sec He 1% F.S. (N ₂ at 25 psig to vacuum, 40 psid)
Differential Operating Pressure Range ²	20-50 psid (atmospheric outlet)
Maximum Operating Inlet Pressure	150 psig
Input Power	±15 ±5% VDC, 300 mA (24 VDC power option, 400 mA)
Maximum Inrush Current ±15 VDC Operation 24 Volt Operation (with 24 V option)	Peak current 9A Rise time 6 u-sec Exponential decay to 3A in 40 u-sec Steady state operating current within 1.4 msec Peak current 16A Rise time 10 u-sec Exponential decay to 3A in 200 u-sec Steady state operating current within 600 msec
Maximum Cable Length	100 feet
Mass Flow Control Range	2 to 100% F.S.
Resolution (measurement)	≤0.1% F.S.

(Continued on next page)

¹ An overall metal braided shielded cable, properly grounded at both ends, is required during use.

² Pressure differential requirement may change due to gas density and flow rate.

Performance Specifications (continued)

Temperature Coefficient	
Zero	$\leq \pm 0.05\%$ F.S./ $^{\circ}\text{C}$
Span	$\leq \pm 0.08\%$ Reading/ $^{\circ}\text{C}$
Settling Time, from zero setpoint	10 – 100% SP ≤ 2 sec. typical
Warm-Up Time	30 minutes

Physical Specifications

Burst Pressure	≥ 1000 psig
Dimensions	1.49" W x 3.00" L (less fittings) x 5.7" H 1.49" W x 5.28" L (face-to-face) x 5.7" H
Fittings	Cajon [®] 4-VCR [®] male compatible (50 SLM range only) Cajon [®] 8-VCR [®] male compatible
Full Scale Ranges	
Flow	50, 100, and 200 SLM
Input Power	± 15 VDC, 300 mA (24 VDC power option, 400 mA)
Maximum Cable Length	100 feet
Valve	
Type	Normally closed
Seat Material	Viton [®] , Buna-N, and Kalrez [®]
Surface Finish	16 μ inches, Ra
Weight	Approx. 3 lbs. (1.4 kg.)
Wetted Materials (excluding valve seat)	316L VAR stainless steel, Elgiloy, nickel, KM-45 SST

Environmental Specifications

Ambient Operating Temperature Range	15 $^{\circ}$ to 40 $^{\circ}$ C (59 $^{\circ}$ to 104 $^{\circ}$ F)
Storage Temperature Range	-20 $^{\circ}$ to 80 $^{\circ}$ C (-4 $^{\circ}$ to 176 $^{\circ}$ F)
Storage Humidity Range	0 to 95% Relative Humidity, non-condensing

These product specifications are subject to change without notice.

Appendix B: Gas Correction Factors

Explanation of Gas Correction Factor (GCF)

Due to differences in specific heat, density, and molecular structure, the output from MFC flow sensors vary with the gas species being flowed. The relationship between indicated flow output and gas species is described by the Gas Correction Factor (GCF).

GCF for a given gas is defined as the ratio of flow rate, in comparison to N₂ (GCF = 1), that will generate the same output voltage. For example, if a mass flow controller calibrated for 100 SLM N₂ is flowing ammonia gas, which has a GCF of 0.73, then a 100% indicated flow output will translate into 73 SLM of ammonia flow.

For traditional analog MFCs, the GCF can be applied in several ways to obtain true gas flow rates, either at the factory or in the field. At the factory, the device can be calibrated for a specific nameplate gas. In the field, users can adjust their process recipes, use voltage dividers on input and output signals or, if using one of several available MKS power supply/readout instruments, gas correction controls on the power supply can be used to compensate for GCF.

The digital capabilities of the MC20A allows separate calibration tables to be created for various gases internal to the device, either at the factory or in the field using the available digital communications kit, P/N 133730-G1/G2. Refer to Appendix E for detailed instructions.

Gas correction factors for common process gases are provided in [Table 11, page 48](#). If the gas you are using is not listed in the table, you can calculate its GCF using the following equation:

$$GCF_x = \frac{(0.3106) (S)}{(d_x) (Cp_x)}$$

where:

GCF_X = Gas Correction Factor for gas X

d_x = Standard Density of gas X, g/l (at 0° C and 760 mmHg)

Cp_x = Specific Heat of gas X, cal/g ° C

0.3106 = (Standard Density of nitrogen) (Specific heat of nitrogen)

S = Molecular Structure correction factor where S equals:

1.030 for Monatomic gases

1.000 for Diatomic gases

0.941 for Triatomic gases

0.880 for Polyatomic gases



Note

1. When using the GCF, the accuracy of the flow reading may vary by ±5%, however, the repeatability will remain ±0.2% of F.S.
2. If a calibration table for a particular gas is created using the digital communications kit, then external correction of the set-point and read-out is not required.
3. All MKS readouts have Gas Correction Adjustment controls to provide direct readout.
4. MKS Types 147/647, 167, 246, 247, 260, and 660 readouts provide gas correction factor adjustment.

Gas Correction Factors Table

The following table lists the theoretical Gas Correction Factors for various gases with respect to Nitrogen. Please note that a non-linearity may exist between a Nitrogen calibration and the actual flow of process gases.



Note Standard Pressure is defined as 760 mmHg (14.7 psia).
Standard Temperature is defined as 0°C.

Table 11: Gas Correction Factors

Gas	Symbol	Specific Heat cc/l/g°C	Density g/l @ 0°C	Conversion Factor
Air	---	0.240	1.293	1.00
Ammonia	NH ₃	0.492	0.760	0.73
Argon	Ar	0.1244	1.782	1.39
Arsine	AsH ₃	0.1167	3.478	0.67
Boron Trichloride	BCl ₃	0.1279	5.227	0.41
Bromine	Br ₂	0.0539	7.130	0.81
Carbon Dioxide	CO ₂	0.2016	1.964	0.70
Carbon Monoxide	CO	0.2488	1.250	1.00
Carbon Tetrachloride	CCl ₄	0.1655	6.86	0.31
Carbon Tetrafluoride (Freon - 14)	CF ₄	0.1654	3.926	0.42
Chlorine	Cl ₂	0.1144	3.163	0.86
Chlorodifluoromethane (Freon - 22)	CHClF ₂	0.1544	3.858	0.46
Chloropentafluoroethane (Freon - 115)	C ₂ ClF ₅	0.164	6.892	0.24
Chlorotrifluoromethane (Freon - 13)	CClF ₃	0.153	4.660	0.38
Cyanogen	C ₂ N ₂	0.2613	2.322	0.61
Deuterium	D ₂	1.722	0.1799	1.00
Diborane	B ₂ H ₆	0.508	1.235	0.44
Dibromodifluoromethane	CBr ₂ F ₂	0.15	9.362	0.19
Dichlorodifluoromethane (Freon - 12)	CCl ₂ F ₂	0.1432	5.395	0.35
Dichlorofluoromethane (Freon - 21)	CHCl ₂ F	0.140	4.592	0.42
Dichloromethylsilane	(CH ₃) ₂ SiCl ₂	0.1882	5.758	0.25
Dichlorosilane	SiH ₂ Cl ₂	0.150	4.506	0.40
1,2-Dichlorotetrafluoroethane (Freon - 114)	C ₂ Cl ₂ F ₄	0.160	7.626	0.22
1,1-Difluoroethylene (Freon - 1132A)	C ₂ H ₂ F ₂	0.224	2.857	0.43
2,2-Dimethylpropane	C ₅ H ₁₂	0.3914	3.219	0.21
Ethane	C ₂ H ₆	0.4097	1.342	0.50

(Continued on next page)

Table 11: Gas Correction Factors (continued)

Gas	Symbol	Specific Heat cc/l/g°C	Density g/l @ 0°C	Conversion Factor
Fluorine	F ₂	0.1873	1.695	0.98
Fluoroform (Freon - 23)	CHF ₃	0.176	3.127	0.50
Freon - 11	CCl ₃ F	0.1357	6.129	0.33
Freon - 12	CCl ₂ F ₂	0.1432	5.395	0.35
Freon - 13	CClF ₃	0.153	4.660	0.38
Freon - 13 B1	CBrF ₃	0.1113	6.644	0.37
Freon - 14	CF ₄	0.1654	3.926	0.42
Freon - 21	CHCl ₂ F	0.140	4.592	0.42
Freon - 22	CHClF ₂	0.1544	3.858	0.46
Freon - 23	CHF ₃	0.176	3.127	0.50
Freon - 113	C ₂ Cl ₃ F ₃	0.161	8.360	0.20
Freon - 114	C ₂ Cl ₂ F ₄	0.160	7.626	0.22
Freon - 115	C ₂ ClF ₅	0.164	6.892	0.24
Freon - 116	C ₂ F ₆	0.1843	6.157	0.24
Freon - C318	C ₄ F ₈	0.1866	8.93	0.164
Freon - 1132A	C ₂ H ₂ F ₂	0.224	2.857	0.43
Helium	He	1.241	0.1786	1.45
Hexafluoroethane (Freon - 116)	C ₂ F ₆	0.1843	6.157	0.24
Hydrogen	H ₂	3.419	0.0899	1.01
Hydrogen Bromide	HBr	0.0861	3.610	1.00
Hydrogen Chloride	HCl	0.1912	1.627	1.00
Hydrogen Fluoride	HF	0.3479	0.893	1.00
Isobutylene	C ₄ H ₈	0.3701	2.503	0.29
Krypton	Kr	0.0593	3.739	1.543
Methane	CH ₄	0.5328	0.715	0.72
Methyl Fluoride	CH ₃ F	0.3221	1.518	0.56
Molybdenum Hexafluoride	MoF ₆	0.1373	9.366	0.21
Neon	Ne	0.246	0.900	1.46
Nitric Oxide	NO	0.2328	1.339	0.99
Nitrogen	N ₂	0.2485	1.250	1.00
Nitrogen Dioxide	NO ₂	0.1933	2.052	0.74 ¹
Nitrogen Trifluoride	NF ₃	0.1797	3.168	0.48
Nitrous Oxide	N ₂ O	0.2088	1.964	0.71
Octafluorocyclobutane (Freon - C318)	C ₄ F ₈	0.1866	8.93	0.164
Oxygen	O ₂	0.2193	1.427	0.993

¹ Consult MKS Instruments for this application.

(Continued on next page)

Table 11: Gas Correction Factors (continued)

Gas	Symbol	Specific Heat cc/g°C	Density g/l @ 0°C	Conversion Factor
Pentane	C ₅ H ₁₂	0.398	3.219	0.21
Perfluoropropane	C ₃ F ₈	0.194	8.388	0.17
Phosgene	COCl ₂	0.1394	4.418	0.44
Phosphine	PH ₃	0.2374	1.517	0.76
Propane	C ₃ H ₈	0.3885	1.967	0.36
Propylene	C ₃ H ₆	0.3541	1.877	0.41
Silane	SiH ₄	0.3189	1.433	0.60
Silicon Tetrachloride	SiCl ₄	0.1270	7.580	0.28
Silicon Tetrafluoride	SiF ₄	0.1691	4.643	0.35
Sulfur Dioxide	SO ₂	0.1488	2.858	0.69
Sulfur Hexafluoride	SF ₆	0.1592	6.516	0.26
Trichlorofluoromethane (Freon - 11)	CCl ₃ F	0.1357	6.129	0.33
Trichlorosilane	SiHCl ₃	0.1380	6.043	0.33
1,1,2-Trichloro – 1,2,2-Trifluoroethane (Freon - 113)	CCl ₂ FCF ₂ or (C ₂ Cl ₃ F ₃)	0.161 0.0810	8.360 13.28	0.20 0.25
Tungsten Hexafluoride	WF ₆	0.0378	5.858	1.32
Xenon	Xe			

Appendix C: Model Code Explanation

Model Code Description

The model code of the MC20A MFC defines features of the unit such as controller type, flow range, fittings, valve configuration, connector type, and seal material.

The model code is identified as follows: **MC20A XXX YY C A**

where:

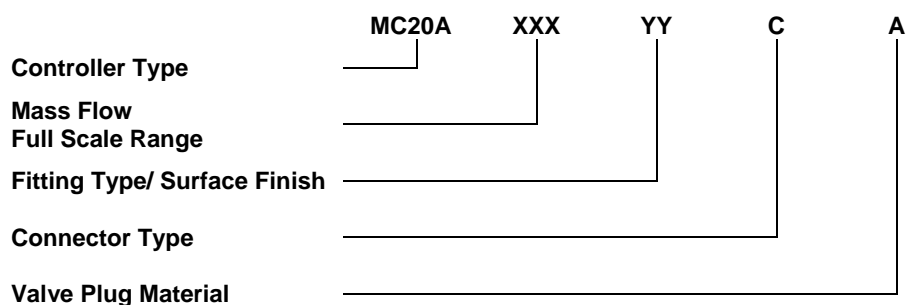

Controller Type

The type identifies your unit as a specific model MC20A MFC.

Mass Flow Full Scale Range (XXX)

The MC20A MFC’s full scale range is indicated by a two digit/one letter code. The first two digits of this code are the flow full scale range in exponential form. The third letter is the flow units. L stands for Standard Liters per Minute.

Example: 12L = 100 SLM

Mass Flow Rate	Ordering Code
50 SLM	51L
100 SLM	12L
200 SLM	22L

FittingType Plus Internal MFC Surface Finish (YY)

The MC20A MFC’s fitting options are designated by an alphanumeric code.

Fitting Style/Internal Finish	Ordering Code	
4 VCR fitting / 16 ra finish	R2	Available for 50 SLM range only.
8 VCR fitting / 16 ra finish	M2	

Connector (C)

The MC20A MFC’s connector is designated by a single number code. The MC20A MFCs are also available with DeviceNet communications.

Connector Type	Ordering Code
15-pin D	B

Valve Plug Material (A)

The MC20A MFC's valve plug material option is designated by a letter code. The plug material is chosen for chemical compatibility with the intended process gas. Viton (code V) is most common.

Valve Plug Material	Ordering Code
Viton	V
Buna-N	B
Kalrez	K



Note

Your MC20A MFC is intended for analog I/O operation with the digital interface and GUI for device set-up only. Upon set-up completion, exit GUI and disconnect the communication cable.



Note

The standard MC20A product is intended for installation in horizontal, base down (HBD) orientation (SEMI E80-U299 Attitude #1).

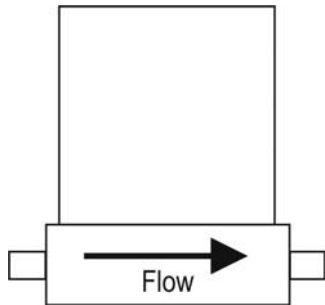

Check the orientation label on the outlet end of the device (on the enclosure). If no label is present, the device is configured for use in the standard HBD orientation. If you intend to install in alternative orientations, contact the MKS Service Department for assistance in reconfiguring.

To order MC20A MFCs with any of the following additional configurations, please consult the MKS factory:

- Alternative gases (other than N₂) and/or special full scale ranges
- MFC mounting orientations besides HBD (SEMI E80-U299 Attitude #1)
- 24 VDC power operation

Appendix D: Mass Flow Controller Sizing Guidelines

General Information

To select the correct controller for an application, you must determine the:

- Flow controller range
- Appropriate valve configuration

The flow controller range depends on the desired flow rate and the gas correction factor for the gas to be used. MKS states the flow controller ranges based on flow rate of nitrogen; the flow rate for other gases may vary.

The proper valve configuration depends upon the flow range, inlet pressure, differential pressure across the unit, and density of the gas. Proper valve configurations have been established for all standard flow ranges flowing nitrogen under standard operating pressures. These configurations are suitable for virtually all gases and pressure conditions.

How to Determine the Flow Controller Range

The controller is available in ranges of 50, 100, and 200 SLM (N₂ equivalent). To select the appropriate range, you must determine the flow rate of nitrogen that is equivalent to the flow rate of the desired gas. Calculate the ratio of the GCF of nitrogen (1.00) to the GCF of the desired gas (refer to Appendix B, *Gas Correction Factors*, page 47), as shown in the following example.



Caution Choose the mass flow controller range for which the N₂ equivalent of the desired process gas and range falls between 55 and 105%.

Example

You need a flow rate of 100 SLM of argon (Ar). What range flow controller should you use?

1. Find the Gas Correction Factor of Ar (1.39, as shown in Appendix B, *Gas Correction Factors*, page 47).

2. Insert the GCF of Ar in the following formula:

$$\frac{(\text{GCF of N}_2)}{(\text{GCF of Ar})} = \frac{(x)}{(\text{Desired flow rate of Ar})}$$

where x is the equivalent flow rate of nitrogen (scm).

$$\frac{(1.00)}{(1.39)} = \frac{(x)}{(100 \text{ SLM Ar})}$$

$$x = 72 \text{ SLM N}_2$$

A flow rate of 100 SLM of Ar will produce a flow rate output equivalent to 72 SLM of N₂. This falls within the range of a 100 SLM flow controller.

When calculating equivalent N₂ flows using gas correction factors, be sure to use a flow controller with a sufficient flow rate range. For example, if the calculated equivalent N₂ flow in the example shown above is 105 SLM, use a 200 SLM flow controller. The 200 SLM instrument can then be calibrated such that 105 SLM N₂ = full scale.

When using a gas with a density *higher* than nitrogen, be sure that the control valve Full Scale range can accommodate the desired flow rate. Please call the MKS Applications group if you have any questions.

This page intentionally left blank.

Appendix E: MKS MC20A Digital MFC Graphical User Interface

Overview

The MC20A line of digital MFCs have calibration and tuning features, which can be altered to expand the operating range of the controllers. Specifically:

- Calibration tables can be copied to new gas tables to allow controller re-ranging or use of alternative gases.
- Entirely new calibration tables can be created by users who have appropriate flow standards.
- Each gas table has different PID tuning parameters associated with it. These can be edited to provide optimum control performance for a particular gases or process conditions. In some cases, a user might create a new gas table where the gas and full scale flow range remain the same as an existing table but only the PID parameters are changed.

To support these features, MKS Instruments provides a graphical user interface (GUI), which provides digital access to the MC20A flow controllers. This appendix describes use of the GUI, which supports the 15-pin analog interface versions of the product.

The GUI is part of a complete software/hardware interface kit, which includes the following components:

- The GUI software on a CD.
- A security hard-key that attaches to either the parallel or USB ports of the Windows-based personal computer.
- RS-232 communication cable, 10 feet long.
- Communication adapter cable.

The kit is available in two configurations:

With USB port security hard key MKS P/N 133730-G1

With parallel port security hard key MKS P/N 133730-G2



Caution Your MC20A MFC is intended for analog I/O operation with the digital interface and GUI for device set-up only. Upon set-up completion, exit GUI and disconnect the communication cable.

Software Setup

The MC20A digital MFC with 15-pin analog interface can run under Windows 98/WinNT/2000 only.

1. Insert the MC20A Analog Application Kit CD into your CD-ROM drive. The setup wizard will automatically start.

If the installation does not automatically start, run *Setup.exe* from the *Setup* directory.

2. Follow the instructions in the Setup wizard.
3. After completing the GUI software installation, install the Hasp Controller Driver by going to **Start** → **Programs** → **MC20A Digital MFC**. Click on the “Hasp Device Driver” pull-down option.

Now you can start running the program.

Equipment Needed

You will need the following equipment:

- MC20A digital MFC with 15-pin analog interface.
- Elements included in the Digital Communications kit, MKS P/N 133730-G1/G2.
 - Graphical user interface (GUI) software, “ALTAAnalogMFC.exe”
 - One security hard-key, linked to the GUI software
 - One RS-232 communication cable
 - One communications adapter cable, MKS P/N 134618-G1
 - One converter module, MKS P/N 134568-P1, inserted between the two cables
- Power supply (± 15 V standard; +24 VDC optional). For ± 15 VDC MFCs, MKS offers a selection of power supplies and accessories.
- Power cable appropriate to the specific analog pin-out configuration. For the standard 15-pin configuration and MKS Model 246/247 power supplies, MKS cable P/N 1480-1 should be used.

Equipment Setup

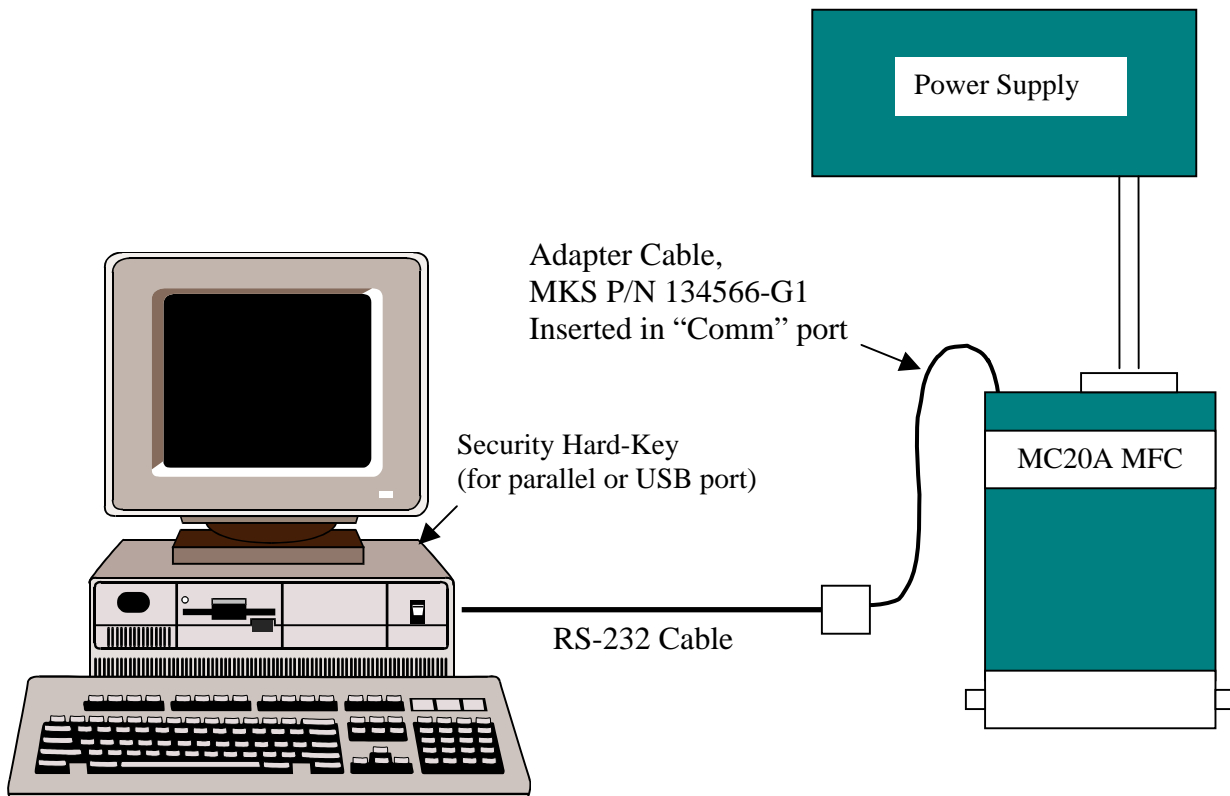

Figure 12: Equipment Setup

Before inserting the connector on the adapter cable (P/N 134618-G1) into the connector on the MFC, orient properly. The blue dot on the cable should face the nearest edge of the controller enclosure.

Starting the GUI

1. Double click the “ALTAAnalogMFC.exe” shortcut on your computer desktop. The program starts and following window appears:

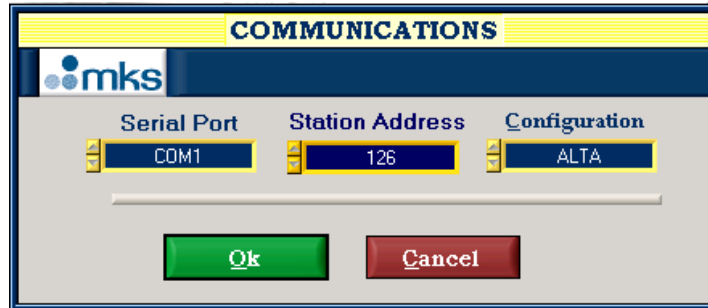

Figure 13: Communications Window

2. Choose the serial port that you connected to (COM1, COM2 ... etc.) on your personal computer.
3. Choose the station address as 126.
4. Click OK to continue. After clicking OK, the following Main Control Panel appears.

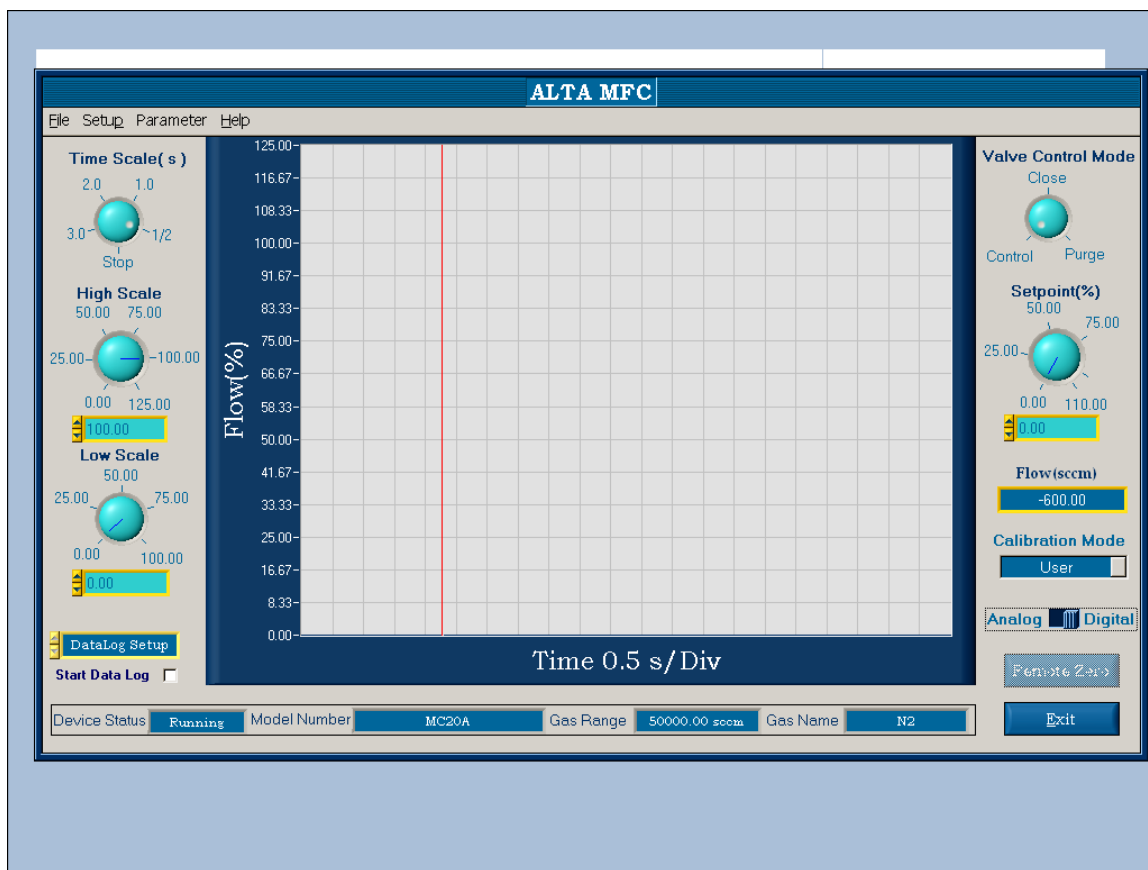

Figure 14: MC20A MFC Main Control Panel

Exiting the GUI



Note

To assure that the flow controller reverts to analog operation (communication through the analog D-connector) prior to disconnecting the communication cable, it is essential to exit the program properly. This can be done in either of two ways:

- Click on the “Exit” button in the lower right corner of the main control panel.
- Click on “File” pull-down and then “Exit.”

Description of the Main Control Panel

Analog	<p>The Analog button toggles the control mode (analog versus digital).</p> <ul style="list-style-type: none"> ■ Analog mode: The GUI provides viewing and data-logging while the MC20A MFC setpoint is controlled by a 0-5 Volt external signal per normal analog operation. Analog mode is the default. ■ Digital mode: This mode allows greater access to digital features of the controller through the comm port. In addition to viewing and data-logging flow, you can: <ul style="list-style-type: none"> — Provide flow setpoints from the GUI front panel. — Override control setpoint to open or close the control valve. — Create new gas tables and change PID control parameters. — Create and change GUI access passwords.
Remote Zero	<p>The Remote Zero button zeros the MC20A MFC. Refer to <i>How to Zero the Flow Controller</i>, page 35, for proper zeroing procedures.</p>
Exit	<p>The Exit button stops the application. <u>Always formally exit the program before disconnecting the MFC.</u></p>
Setpoint (%)	<p>The Setpoint (%) control sets the flow setpoint (in digital mode only). You can click on setpoints indicated on the dial or manually type a setpoint into the space (field) provided.</p>
Control Mode	<p>The Control Mode sets whether the controller is controlling flow, driving its valve full open, or closing its valve. Simply click on the desired mode.</p>
Flow (sccm)	<p>The Flow (sccm) text box displays the current flow rate.</p>
User Mode	<p>The User Mode is used to select the GUI access level as user or calibration. A password is required for calibration access. Refer to <i>User Mode</i> and <i>Calibration Mode</i>, page 59.</p>
Start Data Log	<p>Checking the Start Data Log check box will cause data to be logged in the DataLog.csv file in the current PC drive. This can be opened with Microsoft Excel and then saved as a spreadsheet.</p>
Time Scale, High Scale, Low Scale	<p>The Time Scale, High Scale, and Low Scale dials are used to adjust the scaling of the flow plot while viewing. Simply click on the desired values.</p>

Menu Items

The **File Menu** includes two options:

- Exit
- Print Graph

The **Setup Menu** has the following options:

- Calibrate Flow is used to calibrate the gas table.
- Edit Gas (Add/Select) is used to select, add, or delete gas tables.
- Tuning Parameters is used to set PID values for controller control tuning.
- Password is used to edit the user password.

The **Parameter Menu** has the following options:

- Identity is used to display the hardware identity.
- Current PID is used to show the current PID values.

User Mode and Calibration Mode

The GUI has two access levels, User and Calibration, selected in the User Mode field in the lower right corner of the Main Control Panel.

User Mode When in User mode, the operator has the ability to provide the unit with flow setpoints and then view flow response and flow read-back.

Calibration Mode When in Calibration mode, the operator has nearly full access to the key controller calibration and tuning features. Calibration mode access is password protected. The GUI is delivered with a standard password, which can be changed by the responsible administrator. Also, multiple users can be added, each with their own password.

A more detailed summary is provided in the table below.

Table 12: Summary of User and Calibration Mode Capabilities

User Mode	Calibration Mode
Pick analog versus digital operation.	Same as User mode.
Provide setpoint and view output.	Same as User mode.
Pick valve control mode: purge, close.	Same as User mode.
Adjust scales on the flow output graph.	Same as User mode.
Log flow output data to .csv format file.	Same as User mode.
	Create Calibration mode access passwords.
	Create new gas tables by copying calibration tables; apply new gas correction factors (GCFs) and full scale ranges.
	Change PID tuning parameters associated with particular gas tables.
	Create new calibration tables, if certified suitable flow standard is available (Advanced feature).

Calibration Mode Access

Choosing Calibration mode is done on the Main Control Panel.

1. Click in the User Mode field to reveal a list of choices, which include User and Calibration.
2. Click on Calibration. A small window with fields for the user name and password appears.
3. Input the user name and password in the appropriate fields. The GUI is shipped from MKS with:

User Name: Admin

Password: cal

The password may be changed or new user with their own password added (as described below).

4. Click OK.

Changing a Password for Calibration Mode Access

1. On the Main Control Panel, choose Setup → Password → Change. The following window appears:



The screenshot shows a standard Windows-style dialog box titled "Change Password". The dialog has a light gray background and a blue title bar. It contains four text input fields stacked vertically. The first field is labeled "User Name" and contains the text "Admin". The second field is labeled "Old Password" and is empty. The third field is labeled "New Password" and is empty. The fourth field is labeled "Confirm Password" and is empty. At the bottom of the dialog, there are two buttons: "OK" and "Cancel".

Figure 15: Change Password Window

2. Enter the User Name, Old Password, and New Password in the fields provided.
3. Re-type the new password into the Confirm Password field.
4. Click OK.

Adding a Calibration Mode Password for a New User

1. On the Main Control Panel, choose Setup → Password → New. The following interface appears:



The screenshot shows a 'Change Password' dialog box. The title bar reads 'Change Password'. Inside the dialog, there is a 'User Name' label above a text input field containing 'John_Smith'. Below this are two more text input fields: 'New Password' and 'Confirm Password'. At the bottom of the dialog are two buttons: 'OK' and 'Cancel'.

Figure 16: Adding a Calibration Mode Password for a New User

2. Enter a new User Name and New Password in the fields provided.
3. Re-type the new password in the Confirm Password field.
4. Click OK.

Setting, Adding, and Deleting Gas Tables



Note In order to work with gas tables, the GUI must be in Calibration mode. This is set on the Main Control Panel, in the lower right hand corner.

Accessing Gas Table Editing

Pull down the Setup submenu and choose Edit Gas (Add/Select). The module will load the gas tables and the following window appears:

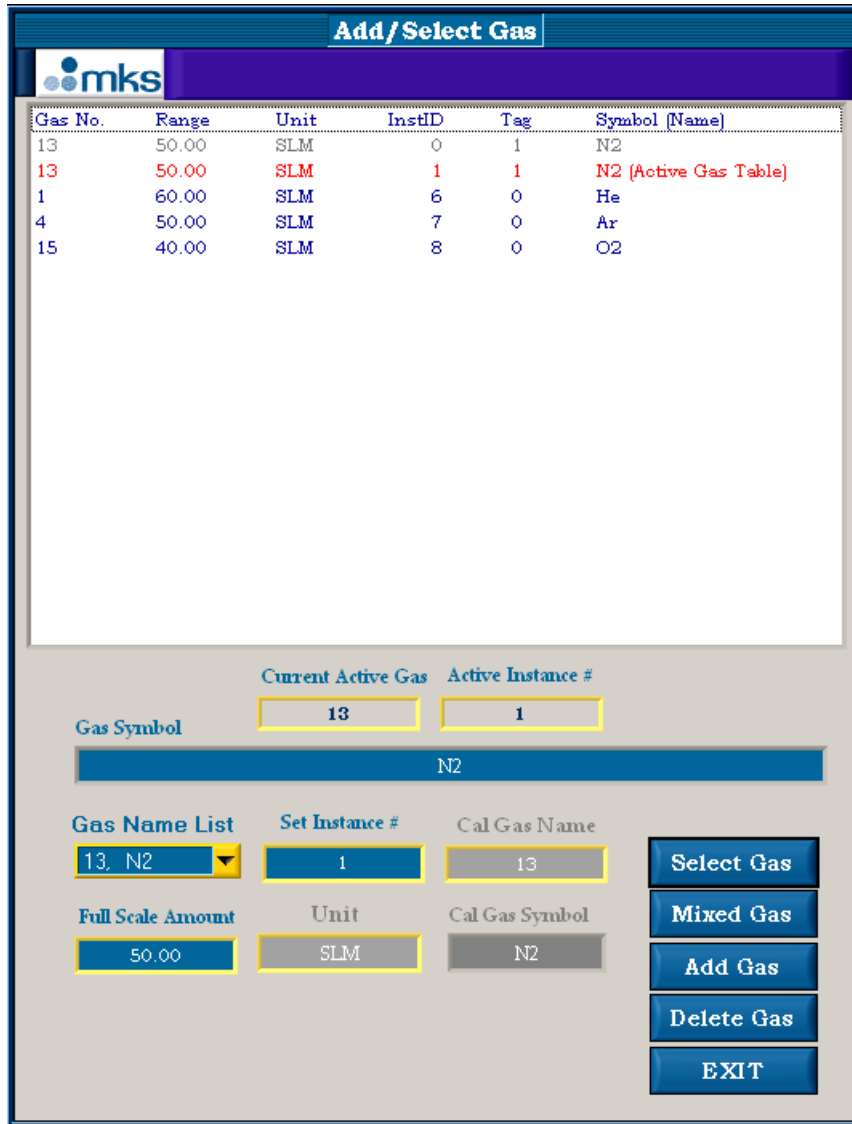

Figure 17: Add/Select Gas

The currently active gas table (Instance ID 1, in this example) is highlighted in red lettering.

Setting a Gas Table and Making the Table Active

1. Point to desired gas table and highlight by clicking on it.
2. Click the Select Gas button.

The gas table choice will be downloaded into the MFC and made active. It will be highlighted in red in the Add/Select Gas window.

Adding a Gas Table

Adding gases is based on copying existing tables. There are several guidelines:

- Gas table instances 0 through 5 may be created only by MKS Instruments. Any new tables must be assigned instance numbers 6 through 19.
- When creating a new table, you may copy only from original calibration tables created by MKS Instruments—instances 0 through 5. Instance 1 is reserved for the “nameplate gas,” which is a copy and should not be used as a source table. In summary, new tables should only be copied from tables of instances 0 and 2 through 5. However, MKS recommends that copies be made only from original gas calibrations. Thus, unless the particular controller has been delivered with multiple calibrations using surrogate gases, the source table should be instance 0.
- The full scale flow range of any new tables must fall between 40 and 110% of the original calibration gas equivalent. For example:

A controller with a standard 50 SLM N₂ calibration allows tables to be created with N₂ equivalent full scale flows of 20 to 55 SLM. Thus, an additional N₂ table with 20 SLM full scale is permitted; but, in creating a He gas table (GCF = 1.45), the specified full scale flow may not be below 29 SL (20 x 1.45). On the other hand, a full scale flow as high as 79.8 SLM (55 x 1.45) is possible.

If an incorrect flow setpoint is input, an error warning will appear. Try again.

The specific steps for adding a new gas table are:

1. In the Add/Select Gas window, enter the desired instance number in the Set Instance # field.
2. Click the Gas List button in Edit Gas window. The gas list will appear, as shown in Figure 19, page 64.



Note

While creating additional gas tables for alternative gases or flow ranges can be a great convenience to users interested in applying the same device configuration to multiple existing process recipes, it should be noted that device accuracy will remain fixed; down-ranging a device by adding a lower range gas table will *not* extend the accuracy to lower flow rates.

For example, per the standard ALTA specifications, a 100 SLM N₂ MFC has an accuracy of 1% of *reading* down to 20% of FS (down to 20 SLM). Below 20% of FS, the unit has an accuracy of 0.2% of FS or 0.2 SLM. This same accuracy will apply to any alternative tables also, as expressed in SLM. If a new gas table is created for 50 SLM N₂ (or N₂ equivalent) full scale output, for instance, the 1% of reading accuracy will continue to hold true down to 20 SLM flow but this flow will now equate to 40% of FS range. Alternatively, a table for maximum N₂ equivalent of 110 SLM would maintain its 1% of Rdg. accuracy down to the original 20 SLM N₂ flow rate. A graphical representation of this example is provided below:

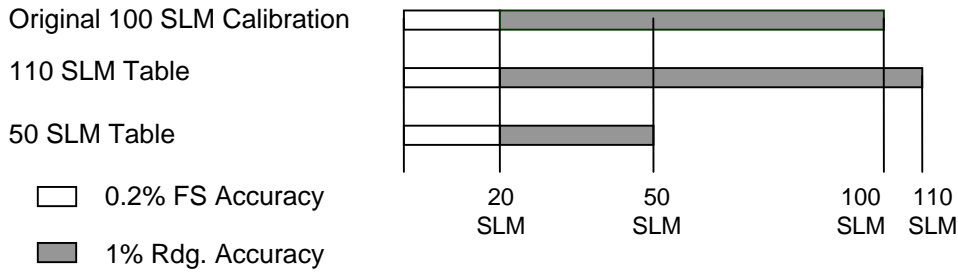

Figure 18: Accuracy Graphical Representation

Gas List				
	Gas Number	GCF	Symbol	Name
1	194	0.340	C3H6O	Acetone
2	173	0.000	C2H3N	Acetonitrile
3	42	0.580	C2H2	Acetylene
4	8	1.000	Air	Air
5	66	0.430	C3H4	Allene
6	29	0.730	NH3	Ammonia
7	4	1.390	Ar	Argon
8	96	0.000	AsF5	Arsenic Pentafluoride
9	35	0.670	AsH3	Arsine
10	79	0.000	BBr3	Boron Tribromide
11	70	0.410	BCl3	Boron Trichloride
12	48	0.510	BF3	Boron Trifluoride
13	21	0.810	Br2	Bromine
14	116	0.260	BrF5	Bromine Pentafluoride
15	76	0.350	BrF3	Bromine Trifluoride
16	105	0.000	C2BrF3	Bromotrifluoroethylene
17	80	0.370	CBrF3	Bromotrifluoromethane (R-13b1)

OK

Figure 19: Gas List

3. Scroll through the list of available gases to find the desired gas. To choose the gas, double click on any box in the row for that gas.

The program will return to the Add/Select Gas window.

- Click the Add Gas button. The Copy Gas window will open.

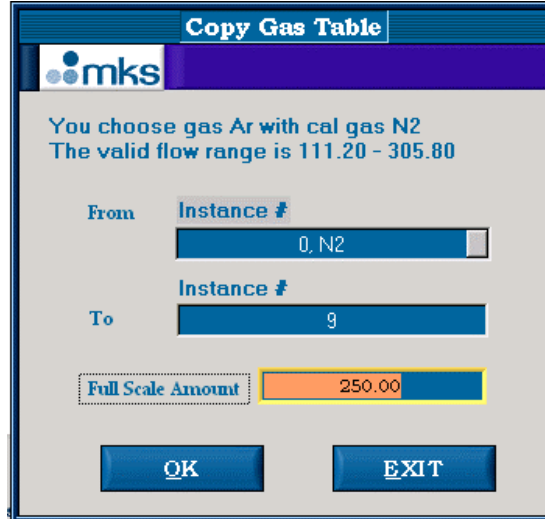

Figure 20: Copy Gas Table

- Click on the drop down box associated with the From field and choose the desired table to be copied. Your choice must be among the factory set instances, 0 through 5.
- Enter the input target Full Scale amount. To assure controller accuracy, this value must be within the limits given in the comments box.
- Click OK to create the new table.

Deleting a Gas Table

- Highlight the gas table to be deleted. Gas table instances 0 through 5 are reserved for use by MKS Instruments only. These may not be deleted.
- Click the Delete Gas button. The table will be deleted from the gas table list.

Adjusting PID Tuning Parameters

1. Make the desired gas table active. To do so:

Access the Add/Select Gas menu on the Main Control Panel by choosing Setup → Edit Gas (Add/Select).

Choose the gas table associated with the PID parameters to be updated. Make it active by highlighting and clicking the Select Gas button.

2. Return to the Main Control Panel. The following window will appear.

- To adjust PID tuning parameters for Flow, select Setup → Tuning Parameters → Flow
- To adjust PID tuning parameters for Optional Input, select Setup → Tuning Parameters → Opt. Input

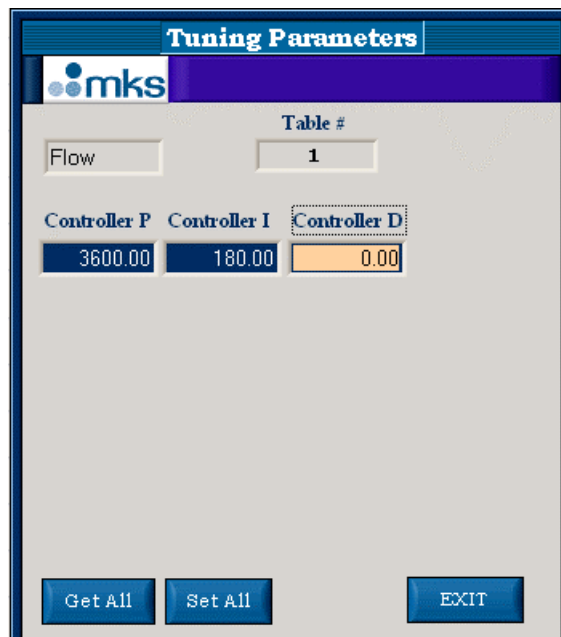

Figure 21: Tuning Parameters

Use this window to get, modify, and set the PID parameters.

- Retrieve values in the active table of the MC20A MFC by clicking the Get All button.
- Update the parameters as desired. Note that MKS generally recommends keeping the Controller D set at zero.
- Download all parameters into the controller by clicking the Set All button.

Viewing Identity Table

The identity table contains identification information regarding the particular MC20A unit.

1. On the Main Control Panel, choose the Parameter → Identity. The following table appears:



Figure 22: Identity Table

2. After reviewing the desired information, click the Close button.

Reading Diagnostic Messages

The MC20A flow controllers provide diagnostic messages that aid users in troubleshooting their systems.

1. Access the Messages window on the Main Control Panel by clicking Parameter → Error Message.
2. Refer to Chapter Six, *Troubleshooting*, page 41, for the table of recommended actions associated with the various messages.

Creating and Modifying Calibration Tables

It is possible to perform gas calibration or adjust existing calibration tables using the Calibration Table Operations window, which is accessed through Set-up → Calibration Flow on the Main Control Panel. This is an *advanced feature*.



Warning

Creating and editing calibration tables is an advanced topic, requiring great care and certified flow standards. Do not proceed unless properly equipped and experienced in MFC calibration.

1. On the Main Control Panel, choose the Setup → Calibrate Flow . The following window appears:

	Actual Flow(%)FS	DUT Output(%)FS	Cal Points	Instance #
1	0.000000	2.600000	13	12
2	1.970000	4.740000		
3	5.000000	10.880000		
4	10.000000	15.620000		
5	20.000000	27.790001		
6	30.000000	38.369999		
7	40.000000	50.980000		
8	50.000000	61.939999		
9	60.000000	74.110001		
10	69.980003	84.709999		
11	80.000000	96.279999		
12	89.989998	106.860001		
13	100.000000	119.480003		
14	0.000000	0.000000		
15	0.000000	0.000000		
16	0.000000	0.000000		
17	0.000000	0.000000		
18	0.000000	0.000000		
19	0.000000	0.000000		
20	0.000000	0.000000		
21	0.000000	0.000000		

Figure 23: Calibration Table Operations

2. Use this window to modify and re-load data. Up to 21 calibration data points are permitted. The default number for factory calibrations is 11 points, including zero.

Creating New Calibration Table

In the Calibration Table Operations window:

1. Input Instance # for the table of interest. This may only be in the range of 6 through 19.
2. Choose the number of Cal Points desired. 11 (including zero) is typical, but up to 21 is possible. The appropriate range of points will become “live” while all points outside of the range will be “grayed-out.”
3. Based on flow testing results, update the “Std. Actual Flow” and “DUT Output” values at the various flow rates of interest. Click in the desired fields and input the applicable flow values.
 - Values in the table should be in % of full scale.
 - For best accuracy, it is recommended that calibration be performed with the controller in metering mode (valve is driven open) and flow is generated by the flow standard. After calibration is complete and values have been downloaded, calibration should be checked at all points with the controller in control mode and output of standard recorded.



Warning Do not perform any calibration unless the controller is properly zeroed. Refer to *How to Zero the Flow Controller*, page 35, for proper zeroing procedures.

4. Click the Set and Save button. This downloads the data to the proper location in the controller for the specified instance.
5. Check calibration at all points with the device in control mode. Provide the device with appropriate setpoints while recording the output of the flow standard.

Modifying Existing Calibration Table

1. Use the Calibration Table Operations window as in creating a new table (above). Remember that only tables associated with instances 6 through 19 may be modified.
2. Click the Get All button.
3. Keep the displayed number of calibration points the same.
4. Based on flow data, edit the table as desired for improved accuracy.



Warning Do not perform any accuracy testing unless the controller is properly zeroed. Refer to *How to Zero the Flow Controller*, page 35, for proper zeroing procedures.

5. Click the Set and Save button. This downloads the data to the proper location in the controller for the specified instance.
6. Check calibration at all points with the device in control mode. Provide the device with appropriate setpoints while recording the output of the flow standard.

This page intentionally left blank.

accuracy of mass flow controller	45	digital error messages	42
ambient operating temperature range	46	digital features	13
burst pressure	46	digital operation	30
cable		dimensions	20, 46
shielded	26	electrical connections	24
cable length	45, 46	electromagnetic compatibility	45
calibration	39	EMC Directive 89/336/EEC	13, 26
calibration mode	59	environmental specifications	46
calibration tables		equipment needed for software	56
creating and modifying	68	error messages	
CE Mark compliance	13, 26	digital	42
cleanliness features	14	error signal	32
commands	37	exiting software	58
priority of	37	features	
connections		cleanliness	14
electrical	24	design	13
connector		digital	13
Type "D"	24	fittings	23
Type "D"	25	4 VCR	20, 21, 22, 23
connector pin-outs		8 VCR	20, 21, 22, 23
location of	20	fittings	46
control		flow	
circuitry	30	control range	29
valve	30	measurement	29
control adjustments	45	path	29
control of flow rate		flow control tuning	
optimizing	31	guidelines	34
control panel, software	58	flow controller	
control repeatability	45	installation	19
control system configuration	29	pressure limits	18
customer support	15	flow rate	
damage	17	control, optimizing	31
derivative control adjustments	45	full scale ranges	46
Derivative term (control)	33	gain	32
adjusting	34	gas connection	19
design features	13	gas correction	
diagnostic messages	67	factors table	48
differential operating pressure range	45	gas correction factor	47

gas flow	23	overriding the valve	37
gas inlet pressure	18	Parameter menu	59
gas tables	30	password	
setting, adding, deleting	62	adding	61
Graphical User Interface (GUI)	31, 55	changing	60
hazardous gases	18	performance	13, 31
identity table	67	accuracy and warm-up	35
input power	45, 46	optimum control	55
inrush current	45	specifications	45
installation	17	physical specifications	46
integral control adjustments	45	PID control	31, 34, 38
Integral term (control)	33	PID parameters	31
adjusting	33	accessing tuning	32
interface		adjusting tuning	66
cables	26	PID tuning	38
connectors	26	pinout assignments	24
interface cables	26	alternative	25
labels	23	power	
leak integrity	45	warm-up and	19
leakage	14, 18, 23, 35	power requirements	18, 24, 25, 35, 45, 46, 56
location		pressure	
product	18, 24	gas inlet	18
maintenance	15, 17, 39	operating inlet	45
manual		operational differential	18
organization of	14	pressure control tuning	
mass flow control		guidelines	34
range	45	pressure limits, flow controller	18
mass flow controller		pressure range	
accuracy	45	differential operating	45
sizing guidelines	53	product specifications	45
mass flow controller range		proportional control adjustments	45
determining	53	Proportional term (control)	32
measurement technique	29	adjusting	32
measurement, resolution	45	reliability	13
model code	51	tests	13
mounting	19, 20, 21	repair	15
hardware	23	requirements	18, 35
orientations	52	mounting	18, 19, 23
operating inlet pressure	45	power	18
operation	35	storage temperature	18
operational differential pressure	18	temperature range	18
optional input	37	ventilation	1, 18

resolution	45	storage humidity range	46
Return Material Authorization (RMA) number ..	15	storage temperature	18
returns	15	storage temperature range	46
safety		STRIFE.....	13
information	1	surface finish choices	46
procedures	1	symbols.....	1
setpoints	13	temperature	
control circuitry and	30	storage.....	18
digital operation.....	30	temperature coefficient.....	46
flow control tuning	34	temperature range	
flow measurement and.....	29	ambient operating	18, 46
flow path and	29	storage.....	46
software control of.....	58	toxic gases	18
target.....	34	troubleshooting.....	41
tuning mass flow rate.....	31	chart	41
settling time.....	46	diagnostic messages	67
setup		tuning.....	31
device.....	19	flow control, guidelines	34
equipment	56	pressure control, guidelines	34
software	55	unpacking	17
Setup menu.....	59	checklist	17
shielded cable description	26	<i>user mode</i>	58, 59
shipment.....	17	valve	
shut-off valves		override	37
systems with downstream only.....	36	seat material	46
systems with upstream and downstream		type	46
positive	36	valve override	37
systems with upstream only	36	ventilation.....	18
sizing guidelines, mass flow controller.....	53	views	
software		bottom	21
exiting.....	58	front and back	20
main control panel	58	inlet end	22
starting	57	top	22
specifications		warm up time.....	18
electrical	45	warm-up time	35, 46
environmental.....	46	weight.....	46
performance.....	45	wetted materials.....	46
physical.....	46	zero	
starting software.....	57	how to	35
starting the MC20A MFC	35	zero adjustment.....	39